



Relacart Electronics CO., LTD.

Guangzhou Office:

Add: Suite 1302, South Tower World Trade Centre Complex,
371 - 375 Huanshi Dong Road, Guangzhou Guangdong China - 510095
Tel: +86 20 38109133
Fax: +86 20 38109384
E-mail: info@relacart.com

Enping Factory:

NO.10 Fu Xing Road, Ping Shi Industrial Zone, Guangdong, China - 529400
Tel: +86- 750 7181209 / 7181210 EX. 623 / 607 (for English)
Fax: +86- 750 7181212
E-mail: info@relacart.com

Relacart Electronics (Hong Kong & Macau) Company Limited

Flat F, 3/F., Phase II, Vigor Industrial Building, 49 - 53 Ta Chuen Ping Street, Kwai Chung, Hong Kong
Tel: +852 31623714
Fax: +852 30074882
E-mail: info@relacart.com

— Real Sound Always



Professional Microphone Series & Conference Systems

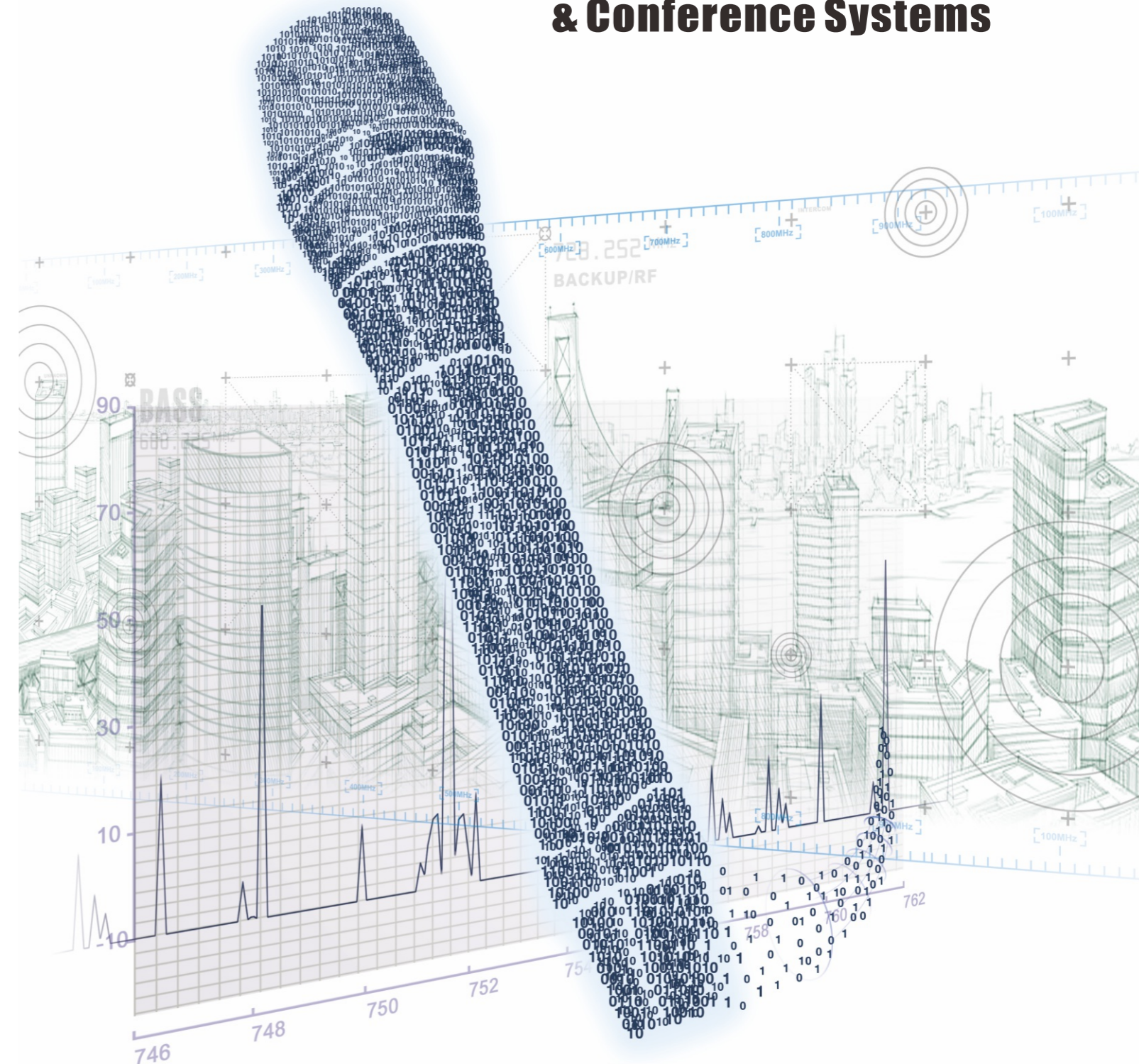

—Real Sound Always

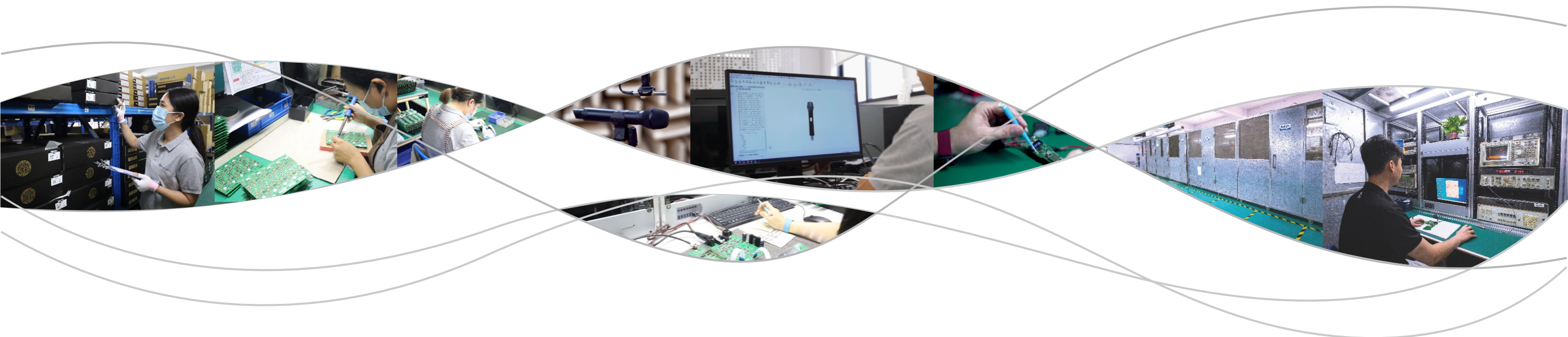

C COMPANY INTRODUCTION

Relacart is a manufacturer of wireless audio system in China over 30 years experience. Relacart brand was founded in 1994, committing to R & D, design, production and sales on microphone and conference system, is a modern enterprise focus on R&D and production of professional audio equipments. Its own brand "Relacart" series of products hot sold at home and abroad, professional wireless microphones and wireless education, tour guide, conference svstem with the most advanced technology in China, accounted for a larger share of the market.

Relacart has a high-quality, highly educated R & D, technical service team and professional sales team, relying on modern management system, is committed to providing all kinds of wireless professional audio products for customers.

Looking to the future, we will continue to adhere to the development of quality, production scale, management professional, business, management of regional differentiation route to construct Relacart.

With the honest and trustworthy corporate image and mutually beneficial cooperative mode to make "Relacart" brand become a win-win bridge between you and me.

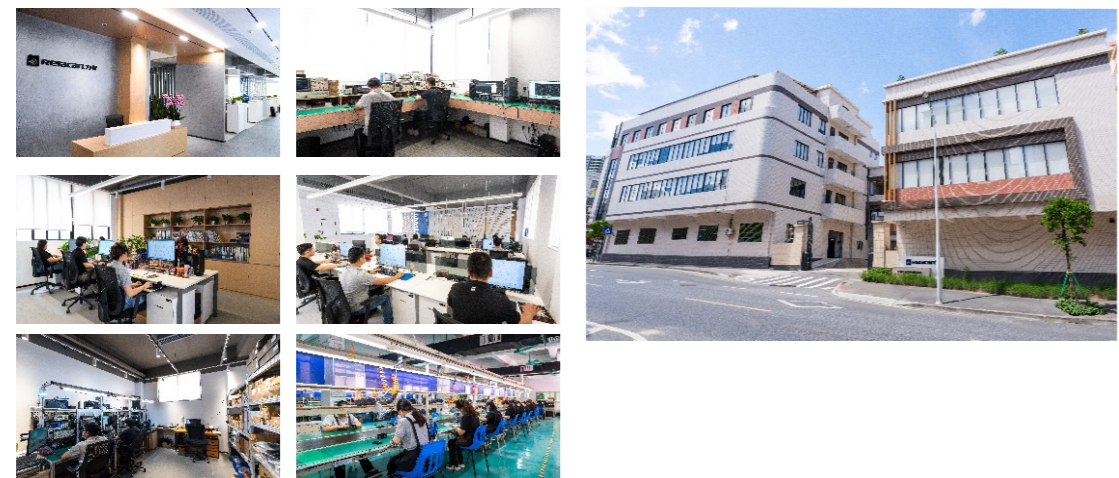

G UANGZHOU COMPANY

Relacart has been a professional wireless audio manufacturer with a history of over 30 years, as well as has been creating the sound experience for masses of users over 30 years. Relacart, a young and mature brand, is showing its unique charm. Young, compared with the century brands, he is really young, and for domestic professional audio brand more than 28 years development course, he is a mature.

With years of development, Relacart has brought the user's unique experience and loud mouth, when asked about the people of cognition Relacart is a consensus: it sounds great, strong stability, in the spread of word-of-mouth. we always believe that quality and service is very critical, so we set up R&D center in Guangzhou city, introduce high-end technical talent make the cooperation smooth from software development to hardware circuit design, to ensure the function plays well as well as the stability is consistent.



CONTENTS



Our products make clients have the experience: Relacart microphone is good. If you want to buy a set of reliable, high performance microphone, you may choose Relacart! High performance, high quality and high technology is the reason that the client keep loyal to you. We pay great attention to the product quality, consist product quality as the base, let quality speak. Our principle mission is to improve the product reliability and strengthen the core technology

Besides the strict requirement on the quality, Relacart pay more attention to service. Relacart has been adhering to the excellence, innovative service concept, extend the service to deeper level "humanized", providing customers with a variety of free technical guidance and training, through the teaching video, real-time remote mentoring, telephone consultation, let the customer not only to learn product knowledge, but also to be learned technical knowledge, to achieve the goal of solving the problem timely and quickly at any time. Effectiveness of service make customers win its own value, and make customers win the approval of Party A. Customer satisfaction, is our infinite power!



FCC

ISO 9001

CE

CE

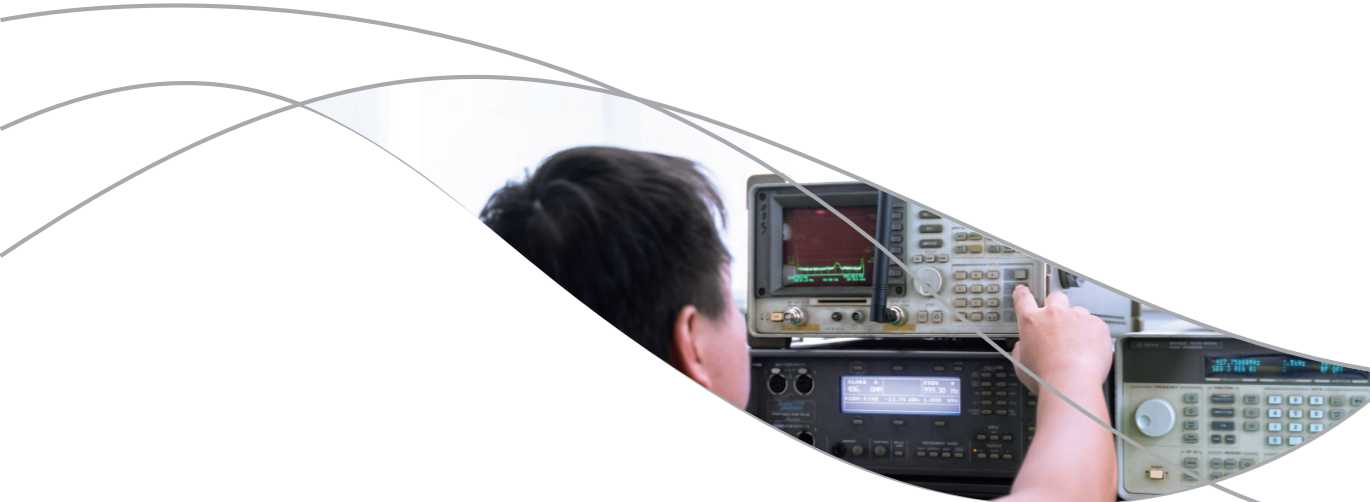

PROFESSIONAL HIGH-PERFORMANCE WIRELESS MICROPHONE SYSTEMS

- True Diversity wireless Digital microphone system
- HR Series True Diversity Wireless Microphone Systems
- Portable Spectrum Analyzer
- Wireless Spectrum Analyzer
- Quad-Channel True Diversity Wireless Microphone System
- True Diversity Wireless Microphone Systems

UR Series Antenna Diversity Wireless Microphone Systems

- 2.4G Single-Channel Tri-Diversity Wireless Microphone System
- IEM Transmitter Antenna Combiner
- Wireless In-ear Monitor System
- Portable Audio Adapter
- UHF True Diversity ENG Wireless Receiver
- Antenna Distribution Systems
- Antennas
- Accessories

PROFESSIONAL WIRELESS MICROPHONE SYSTEMS FOR ENTERTAINMENT

- ER Series True Diversity Wireless Microphone Systems

WIRED MICROPHONES

- Dynamic Microphone
- Condenser Microphone
- Small Diaphragm Condenser Microphone

INTEGRATED SYSTEMS

- Wired digital conference discussion system
- Dante Digital & Wireless Conference Discussion Systems
- Wireless Automatic Mixers
- Dante Digital & Wired Conference Discussion Systems

- Wired Conference Discussion Systems
- AI Noise Cancellation Audio Processor
- Digital Automatic Mixers with Dante Interface

- Digital Automatic Mixer
- Video Tracking System
- Wireless Tour Guide Microphone System
- Dante Networked Audio Interface
- Microphone Array System
- Dante Microphones
- AI Ceiling Microphone

- Dante-enabled Networked Speakers
- Dante Microphones and Speakers Management Software
- Professional Desktop Microphones
- Gooseneck Microphone Desk Stand
- Flush-mount Microphone Socket
- Gooseneck Microphones

- Wired Boundary Microphones
- Wireless Microphone Systems For Education

Accessories

DIGITAL LIVE SOUND MIXERS

- Digital Mixer
- Digital Mixer with Dante Interface

CONSUMER ELECTRONICS

- True Diversity Wireless Digital Microphone System
- 2.4G Ultra-compact Wireless Microphone Systems
- Wireless In-ear Monitor System
- Dynamic Podcast Microphone
- Shotgun Condenser Microphone
- Audio Interface & Mixers

Accessories

PROJECT APPLICATION

UR-D Series NEW	01
HR-32Series	03
HR-31S	07
U.Discover NEW	09
SA-960 NEW	11
UR-2Q	13
UR-280 NEW	15
UR-290 NEW	17
UR-290D NEW	19
UR-223 Series	21
UR-260D	25
UR-222 Series	27
UR-111S	31
BG-24 NEW	33
TAC4 NEW	35
PM-320	37
4 Port Go NEW	39
HCR-30D	41
R-14D	43
R-32AU /R-20U /R-43W	45
Accessories	47

ER-5900	55
---------	----

VX-300 NEW	57
SM-300 KM-100	58
PM-100	58
MiLIVE	59

DCS-303 NEW	63
WDC Series NEW	65
WAM-432 AMC-20	71
CS-302	77
CS-360	79
CS-102	81
AI-NC100 NEW	83
DAM-128D	85
DAM-208D	87
CONFER X	89
DAM-124	91
VTS-2000	93
TGS-6	95
BLOCK 4+	97
MAS-D	99
TDN3 / TDN2 / TDN1/TDN1-F	101
ACM-335 NEW	107
ACM-582 NEW	109
RDA-10 /RDA-20	111
RDM/TDM Software	113
TSG/RG Series	115
TS Seres	117
FM Series	119
AL/GS/EG/ES Series	121
CF/GF/MS Series	123
Bases and Microphone's Matching	125
BM-110 111	127
IMIC-6 NEW	129
IMIC-6D(Dante) NEW	131
TM-500	133
Accessories	135

MIXX16	139
MIXX12	141

EZD Series NEW	143
EZ Series	145
Mi3	149
PM-100D	151
PM Series	153
SM2	159
Podcast+	161
MIXX8.6	163
Mikit	165
LM-P01	167
Accessories	169

Stage and Music Performances	171
Conferecing Projects	
Entertainment and KTV Rooms	

UR-D1/D2 | UHF DIVERSITY DIGITAL WIRELESS MICROPHONE SYSTEM



Dante
wireless management system
MIDIGIX
Algorithm

The UR-D series is Relacart's latest fully self-developed digital architecture wireless microphone system. Combining powerful functionality with operational flexibility, it features a 64MHz operating bandwidth and low intermodulation distortion, enabling 20 simultaneously active transmitters within an 8MHz bandwidth and supporting over 60 compatible channels in a single frequency band. This ensures stable wireless transmission even in crowded RF environments. With 24-bit/48kHz digital audio quality, the system accurately reproduces sonic details beyond the capabilities of analog systems. A total system latency of <3ms and a flat frequency response across 20Hz–20kHz ensure precise vocal reproduction—from deep resonances to high-frequency nuances—delivering transparent, high-fidelity sound. A dynamic range exceeding 120dB provides exceptional signal-to-noise performance. Designed for easy installation and integration, the system can be seamlessly expanded via existing Dante networks, scaling from small conference rooms or classrooms to large campus and enterprise installations. Advanced features enable detailed configuration management while simplifying complex channel and audio setups. Additionally, the WireMicX Wireless management system supports remote system maintenance, monitoring, and control for streamlined operation.

Product Specification



UR-D1
Single Channel Wireless Receiver



UR-D2
Dual Channel Wireless Receiver

- The system incorporates intelligent predictive diversity reception technology, which preemptively assesses signal quality and uses algorithmic optimization to maintain stable transmission. It fully meets the complex demands of multi-channel, large-scale audio applications.
- For secure transmission needs, AES-256 encryption is available—ideal for confidential meetings—ensuring privacy protection. This encryption also eliminates RF interference by allowing only encrypted signals to be received.

Chassis Specification:	1U Half-Rack(UR-D1) EIA Standard 1U(UR-D2)
Reception Method:	Diversity Single-Channel Reception(UR-D1) Diversity Dual-Channel Reception(UR-D2)
Frequency Stability:	±0.005%
Carrier Frequency Range:	470MHz–936MHz
Operating Range:	100 meters (open area)
Sampling Rate:	24-bit/48kHz
Frequency Response:	20Hz–20kHz ±1dB
Modulation Method:	Relacart Patented Digital Technology
Bandwidth:	64MHz (region-dependent)
Overall S/N Ratio:	>110dB
Total Harmonic Distortion (T.H.D.):	<0.1% @1kHz
RF Tuning Step:	25kHz
Image Rejection:	>70dB (typical)
RF Sensitivity:	-98 dBm @ 10 BER
Latency:	<3ms
Audio Dynamic Range (A-weighted, typical, system gain @ +10):	>120dB
Total Harmonic Distortion (-12dBFS input, system gain @ +10):	<0.1%
Operating Temperature Range:	-10°C to 50°C
Storage Temperature Range:	-20°C to 70°C
Power Supply:	DC 12V/1A
Antenna Interface:	Dual BNC, Supports +12V/150mA Output
Audio Output Interfaces:	6.3mm Unbalanced Audio Output, 2× XLR Balanced Audio Output
Dimensions (mm):	UR-D1:205 (L) × 206 (W) × 43 (H) UR-D2:410 (L) × 206 (W) × 43 (H)
Weight(Approx):	UR-D1:1kg UR-D2:2kg

Key Features

64MHz System Bandwidth

- With an ultra-wide 64MHz system bandwidth — broader than most comparable products on the market — the system offers abundant frequency options even in large-scale events requiring multiple devices. This makes it easier to avoid interference and ensure stable performance.

AES-256 Encryption

- Equipped with AES-256 high-level encryption suitable for any scenario requiring secure transmission, such as confidential meetings. This ensures privacy protection while simultaneously eliminating RF interference by allowing only encrypted signals to reach the receiver.

Dante Network Audio Protocol

- UR-D2 Features Dante network audio output, which automatically identifies the product's Dante channels. Audio signals can be seamlessly routed to any Dante-compatible audio device.

Intelligent Predictive Diversity Reception

- Utilizing intelligent predictive diversity reception technology, the system preemptively gathers signal quality data and employs algorithmic optimization to maintain consistent transmission stability. It fully meets the complex demands of multi-channel and large-scale audio transmission.

WireMicX Wireless Management System

- Compatible with Relacart's professional WireMicX Wireless management system, enabling computer connectivity for remote monitoring, management, and control of the system — simplifying operation and maintenance.

High-Fidelity Sound Quality

- Incorporates lossless audio transmission technology with 24-bit/48kHz sampling and total system latency below 3ms. Delivers a flat frequency response across 20Hz–20kHz, accurately reproducing the full spectrum of vocal details — from deep resonances to high-frequency nuances.



UR-D1H
Wireless Handheld Microphone

- UR-D1H Wireless Handheld Microphone Crafted from durable alloy with a sleek and modern design, the UR-D1H wireless handheld microphone is fully compatible with the Relacart UR-D Series Digital Wireless Microphone System. It features a cardioid pickup pattern that effectively suppresses ambient noise from the sides and rear.
- Equipped with a high-quality dynamic microphone capsule, it delivers an extended frequency response and captures rich, detailed sound with exceptional clarity. Ideal for high-fidelity studio recording and premium live performances where superior audio quality is essential.

Carrier Frequency Range:	470MHz–936MHz
Audio Frequency Response:	20Hz–20kHz ±1dB
Harmonic Radiation:	>45dB below carrier
Bandwidth:	64MHz per channel (region-dependent)
Modulation:	Relacart Patented Digital Technology
Occupied Bandwidth:	200kHz
Impedance:	50Ω
RF Output Power:	High / Medium / Low (selectable)
Gain Adjustment Range:	+15dB to -5dB (1dB steps)
Battery:	2×AA
Current Consumption:	270mA (typical)
Battery Life:	Approx. 8 hours (alkaline)
Dimensions (mm):	55(Φ) × 269 (L)



UR-D1B
Wireless Bodypack Transmitter

- UR-D1B Bodypack Transmitter is an exceptionally compact and lightweight bodypack transmitter designed for comfortable, unobtrusive wear on the waist or clothing. Compatible with the Relacart UR-D Series Digital Wireless Microphone System, it features a 4-pin mini XLR interface for connecting headset or lapel microphones.
- Powered by two AA batteries and engineered with precision circuitry, it delivers up to 8 hours of continuous operation. Ideal for stage performances, video recording, live broadcasts, and interviews.

Carrier Frequency Range:	470MHz–936MHz
Audio Frequency Response:	20Hz–20kHz ±1dB
Harmonic Radiation:	>45dB below carrier
Bandwidth:	64MHz per channel (region-dependent)
Modulation:	Relacart Patented Digital Technology
Occupied Bandwidth:	200kHz
Audio input:	4-pin mini XLR connector
Impedance:	50Ω
RF Output Power:	High / Medium / Low (selectable)
Gain Adjustment Range:	+15dB to -5dB (1dB steps)
Battery:	2×AA
Current Consumption:	270mA (typical)
Battery Life:	Approx. 8 hours (alkaline)
Dimensions (mm):	65 (L)×21.3 (W)×75.5 (H)

HR-32D | HR DUAL-CHANNEL TRUE DIVERSITY WIRELESS MICROPHONE SYSTEM



The HR-32D is a dual-channel wireless microphone system integrating a spectrum analyzer and wireless audio transmission. The spectrum analyzer serves to visualize the system's frequencies, ensuring optimal controllability and stability in any performance setting, and delivering pristine, immersive sound quality. The HR-32 series combines digital audio with an analog FM radio link to provide outstanding audio quality and the exemplary RF performance of the finest analog wireless systems with the low noise and low audio distortion of digital wireless, offering 130 MHz switching bandwidth (depending on region), flexible frequency management, upgradeable WireMicX Wireless System Management Software, reliable, simple yet sophisticated technology, and rugged housing for protection. This fully functional and flexible wireless microphone system provides professionals with more excellent choices and fully proves Relacart's professionalism in all kinds of performances.

Key Features

Digital Hybrid Dante Wireless System

- Revolutionary design that combines digital audio with an analog FM radio link to provide both outstanding audio quality and exemplary, noise-free RF performance.

WireMicX Wireless Management System

- WireMicX Wireless System Management Software, can be connected to PC network to monitor and search for radio wave interference points in the actual environment of the scene and frequency dead spots on the stage.

Digital Audio Output

- HR series provides two digital audio outputs – for DANTE/AES67

AFS(Automatic Frequency Selection)

- With AFS function, can automatically search for clean and interference-free frequencies in the actual environment. Enter the setting menu and select the AFS function, and it will automatically search and lock on a interference-free in the actual working environment.

DSP DSP Audio Digital Extension

- High-speed DSP chip, 24-bit high-performance ADC, DAC and self-developed digital audio extension algorithm are used to reduce the noise caused by wireless transmission.

PLL PLL Frequency Synthesis Oscillation Circuit

- The stable PLL phase-locked oscillation circuit, combined with the "noise detection" mute control function, can effectively block the noisy radio frequency interference in the working environment.

Signal Frequency Visualization

- The radio frequency details of the current environment can be monitored in real time on the display screen of the receiver, and the interference-free frequency can be viewed and selected through the screen.

Product Specification



HR-32D
Dual Channel Wireless Receiver

- HR-32D Dual Channel True Diversity Wireless Microphone System has innovative wireless audio technology and unique features. PLL Phase Locked Loop circuit and equipped with frequency visualization screen, making the signal is fully protected.
- With Dante network audio output.

Main Frame Size:	EIA Standard Rack 1U
Receiving Channel:	Dual Channel
Receiving Mode:	True Diversity
Frequency Reliability:	±0.005%(-10~50°C)
External Antenna Interface:	BNC, DC 12-18V/150mA output
External Audio Interface:	Mixed XLR output, independent channel XLR output
Ethernet Port:	Support Dante communication protocol
Receiving Frequency Band:	521.25MHz-936.85MHz
Working Mode:	PLL frequency synthesis oscillation and secondary mixing reception technology
Receiving Sensitivity:	When the offset is equal to 25KHz and 5dBu is input, S/N>60dB
Bandwidth:	Single channel 130MHz (depending on the region)
Max. Deviation:	±50KHz
Audio Sampling Rate:	96KHz 24-bit
Audio Extension:	Relacart DSP digital audio extension algorithm
Comprehensive S/N:	>105dB
Comprehensive T.H.D:	<0.7%@1KHz
Frequency Response:	60Hz-18KHz ±3dB
Working Range:	100M Typical(in open space)
Power Mode:	DC 12-18V
Dimension(mm):	410(W)×206(D)×43(H)



H-32
Wireless Handheld Microphone



H-33
Wireless Handheld Microphone

- Specially hardened aluminum housing provides light weight and high durability
- Detachable microphone capsule module design, can work with the latest version dynamic and condenser microphone capsule module of Relacart HR series, and the mic body is compatible with many mic capsule module with standard interface of Sennheiser.
- The high-brightness OLED display can clearly display the working status of the microphone in any scene
- Hidden button design to prevent wrong operation during use
- An illuminated light touch switch on the tail with a mute function, when the microphone is in low battery, the light will turn red and flash to remind
- The gain and RF strength of the microphone can be adjusted according to the needs of the scene through the menu of the microphone

Carrier Frequency Range:	521.25MHz~936.85MHz
Harmonic Radiation:	<45dBm
Bandwidth:	Single channel 134MHz (depending on the region)
Modulation:	FM
Audio Compression:	Relacart classic audio compression circuit
Microphone Element:	Dynamic/Condenser(removable)
RF Output Power:	10mW/50mW
Battery:	AA×2
Current Consumption:	130mA(Typical)
Battery Current/ Life:	Approximately 10 hours(alkaline)
Dimension(mm):	53(Φ) ×275(L)
Weight:	Approximately 322g(w/o battery)

- The bodypack transmitter is one of the smallest mini bodypack in the world. It is made of all alloys and is light and durable.

Carrier Frequency Range:	521.25MHz~936.85MHz
Oscillation:	PLL synthesized
Harmonic Radiation:	<50dBm
Max. Deviation:	±45KHz
Input Connector:	4-pin mini XLR connector
RF Output Power:	10mW/40mW
Battery:	AA×1
Current Consumption:	205mA(Typical)
Battery Current/ Life:	Approximately 5 hours(alkaline)
Dimension(mm):	66(H)×63(W)×20(D)
Weight:	Approximately 85g(w/o battery)



T-32
Wireless Bodypack Transmitter

HR-32S | HR SINGLE-CHANNEL TRUE DIVERSITY WIRELESS MICROPHONE SYSTEM



Dante®

Built-in Spectrum Analysis



The HR-32S is a single-channel wireless microphone system integrating a spectrum analyzer and wireless audio transmission. The spectrum analyzer serves to visualize the system's frequencies, ensuring optimal controllability and stability in any performance setting, and delivering pristine, immersive sound quality. The HR-32 series combines digital audio with an analog FM radio link to provide outstanding audio quality and the exemplary RF performance of the finest analog wireless systems with the low noise and low audio distortion of digital wireless, offering 130 MHz switching bandwidth (depending on region), flexible frequency management, upgradeable WireMicX Wireless System Management Software, reliable, simple yet sophisticated technology, and rugged housing for protection. This fully functional and flexible wireless microphone system provides professionals with more excellent choices and fully proves Relacart's professionalism in all kinds of performances.

Key Features

Digital Hybrid Dante Wireless System

- Revolutionary design that combines digital audio with an analog FM radio link to provide both outstanding audio quality and exemplary, noise-free RF performance.

WireMicX Wireless Management System

- WireMicX Wireless System Management Software, can be connected to PC network to monitor and search for radio wave interference points in the actual environment of the scene and frequency dead spots on the stage.

Digital Audio Output

- HR series provides two digital audio outputs – for DANTE/AES67

AFS(Automatic Frequency Selection)

- With AFS function, can automatically search for clean and interference-free frequencies in the actual environment. Enter the setting menu and select the AFS function, and it will automatically search and lock on a interference-free in the actual working environment.

DSP DSP Audio Digital Extension

- High-speed DSP chip, 24-bit high-performance ADC, DAC and self-developed digital audio extension algorithm are used to reduce the noise caused by wireless transmission.

PLL PLL Frequency Synthesis Oscillation Circuit

- The stable PLL phase-locked oscillation circuit, combined with the "noise detection" mute control function, can effectively block the noisy radio frequency interference in the working environment.

Signal Frequency Visualization

- The radio frequency details of the current environment can be monitored in real time on the display screen of the receiver, and the interference-free frequency can be viewed and selected through the screen.

Product Specification



HR-32S Single Channel Wireless Receiver

- HR-32S Single Channel True Diversity Wireless Microphone System has innovative wireless audio technology and unique features. PLL Phase Locked Loop circuit and equipped with frequency visualization screen, making the signal is fully protected.
- With Dante network audio output.

Main Frame Size:	EIA Standard Rack 1U
Receiving Channel:	Single Channel
Receiving Mode:	True Diversity
Frequency Reliability:	±0.005%(-10~50°C)
External Antenna Interface:	BNC, DC 12-18V/150mA output
External Audio Interface:	Mixed XLR output, independent channel XLR output
Ethernet Port:	Support Dante communication protocol
Receiving Frequency Band:	521.25MHz-936.85MHz
Working Mode:	PLL frequency synthesis oscillation and secondary mixing reception technology
Receiving Sensitivity:	When the offset is equal to 25KHz and 5dBu is input, S/N>60dB
Bandwidth:	Single channel 130MHz (depending on the region)
Max. Deviation:	±50KHz
Audio Sampling Rate:	96KHz 24-bit
Audio Extension:	Relacart DSP digital audio extension algorithm
Comprehensive S/N:	>105dB
Comprehensive T.H.D.:	<0.7%@1KHz
Frequency Response:	60Hz-18KHz ±3dB
Working Range:	100M Typical(in open space)
Power Mode:	DC 12-18V
Dimension(mm):	410(W)×206(D)×43(H)



H-32 Wireless Handheld Microphone

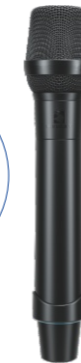

H-33 Wireless Handheld Microphone

- Specially hardened aluminum housing provides light weight and high durability
- Detachable microphone capsule module design, can work with the latest version dynamic and condenser microphone capsule module of Relacart HR series, and the mic body is compatible with many mic capsule module with standard interface of Sennheiser.
- The high-brightness OLED display can clearly display the working status of the microphone in any scene
- Hidden button design to prevent wrong operation during use
- An illuminated light touch switch on the tail with a mute function, when the microphone is in low battery, the light will turn red and flash to remind
- The gain and RF strength of the microphone can be adjusted according to the needs of the scene through the menu of the microphone

Carrier Frequency Range:	521.25MHz~936.85MHz
Harmonic Radiation:	<45dBm
Bandwidth:	Single channel 134MHz (depending on the region)
Modulation:	FM
Audio Compression:	Relacart classic audio compression circuit
Microphone Element:	Dynamic/Condenser(removable)
RF Output Power:	10mW/50mW
Battery:	AA×2
Current Consumption:	130mA(Typical)
Battery Current/ Life:	Approximately 10 hours(alkaline)
Dimension(mm):	53(Φ) ×275(L)
Weight:	Approximately 322g(w/o battery)

- The bodypack transmitter is one of the smallest mini bodypack in the world. It is made of all alloys and is light and durable.

Carrier Frequency Range:	521.25MHz~936.85MHz
Oscillation:	PLL synthesized
Harmonic Radiation:	<50dBm
Max. Deviation:	±45KHz
Input Connector:	4-pin mini XLR connector
RF Output Power:	10mW/40mW
Battery:	AA×1
Current Consumption:	205mA(Typical)
Battery Current/ Life:	Approximately 5 hours(alkaline)
Dimension(mm):	66(H)×63(W)×20(D)
Weight:	Approximately 85g(w/o battery)



T-32 Wireless Bodypack Transmitter

HR-31S

HR SINGLE-CHANNEL TRUE DIVERSITY WIRELESS MICROPHONE SYSTEM



HR-31S true diversity wireless microphone system is a wide bandwidth true diversity wireless audio system that designed for the large-scale live show. Powerful function, reliable performance, can get the best effect in different kinds of complicated professional performance.

Product Specification



HR-31S Single Channel Wireless Receiver

- 1U Half-Rack receiver chassis, offering programmable features, with high-visibility LCD display.
- The receiver's bright LCD display the operating channel or frequency, RF and AF signal strength, transmitter battery capacity, and the ability to edit the performer's name for easy tuner control.
- Electronic Volume Control
- Antenna output with 8V DC

Main Frame Size:	1U Half-Rack
Receiving Channel:	Single Channel
Receiving Mode:	True Diversity
Frequency Reliability:	±0.005%(-10~50°C)
Bandwidth:	32MHz
Audio Output Jack:	XLR balanced socket and Φ6.3mm unbalanced socket
Antenna Socket Type:	BNC
Control Cable:	4P telephone line connect to the U485, U485 USB connect to computer.
Operation Distance:	80M typical(in open space)
Oscillation:	PLL synthesized
Sensitivity:	5dBμV,S/N>60dB at 25KHz deviation
Max. Deviation:	±45KHz
Power Supply:	DC 12V/12W
Dimension(mm):	206(W)×206(D)×43(H)
Weight:	Approximately 1.0kg

Key Features

AFS(Automatic Frequency Selection)

- Press the "AFS"(Auto Frequency Selection) button 3S and the receiver will auto-scan and lock on to an open, interference-free frequency.

Anti-Interference

- PLL (Phase Lock Loop frequency control) design ensures transmission reliability, "Noise Lock" squelch effectively blocks stray RF.

IR Infrared

- Press [IR] button to upload automatically the receiver frequency to the transmitter.

Super Wide Frequency Range

- 32MHz bandwidth. 1280 selectable UHF frequencies and True Diversity reception for interference-resistant operation.

Intelligent Management

- On-board Ethernet interface for monitoring and controlling system parameters with "RW" wireless management system.
- Intelligent volume control

Energy Conservation

- Precision low-power circuit design, battery life is twice as common.



H-31 Wireless Handheld Microphone

- The transmitters offer durable, magnesium bodies, soft-touch controls. Effectively protects inside PCB board components and battery holders with an ergonomic grip.
- With lock function, avoid the mistakes of the performers, to ensure reliable performance.

Carrier Frequency Range:	521.25MHz~936.85MHz
Oscillation:	PLL synthesized
Harmonic Radiation:	<20dBm
Max. Deviation:	±45KHz
Microphone Element:	Dynamic/Condenser(removable)
RF Output Power:	10mW/40mW
Battery:	AA×2
Current Consumption:	100mA(Typical)
Battery Current/ Life:	Approximately 10 hours(alkaline)
Dimension(mm):	53(Φ) ×265(L)
Weight:	Approximately 312g(w/o battery)



T-32 Wireless Bodypack Transmitter

- The bodypack transmitter is one of the smallest mini bodypack in the world. It is made of all alloys and is light and durable.

Carrier Frequency Range:	521.25MHz~936.85MHz
Oscillation:	PLL synthesized
Harmonic Radiation:	<50dBm
Max. Deviation:	±45KHz
Input Connector:	4-pin mini XLR connector
RF Output Power:	10mW/40mW
Battery:	AA×2
Current Consumption:	205mA(Typical)
Battery Current/ Life:	Approximately 5 hours(alkaline)
Dimension(mm):	66(H)×63(W)×20(D)
Weight:	Approximately 85g(w/o battery)

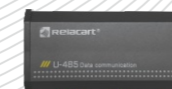

U-485 Data exchange equipment

- U-485 is a device for some of the exclusive wireless products and computer data exchange.
- We set up our computer software (RW) to achieve the work of the connected wireless microphone products. It can be computerized, but more powerful is to accurately determine the internal environment interference. Obvious signal changes and the scan function.

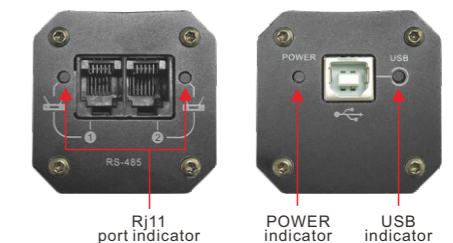

- Product port description
 - ①USB interface: professional square USB interface for connecting to a computer for data exchange
 - POWER indicator: Power indicator, correctly shows whether the U-485 is working properly (the power supply can be supplied via USB)
 - USB indicator: Indicates whether the U-485 is connected to the computer.

②Two RJ11 ports: used to connect to our exclusive wireless microphone products, the 1 and 2 ports function are same, can be used at the same time so that it can connect more wireless microphone at the same time. RJ11 port indicator *2: indicate whether the RJ11 port connection is normal.



U.Discover is a portable handheld spectrum management controller that adopts an ultra-wideband solution and can scan frequencies from 240MHz-960MHz. It is equipped with a HD screen to display frequency details, making it clear at a glance the on-site interference frequencies. It can create a stable wireless working environment for the site, making the site frequency visible and controllable.

Product Specification



Input Frequency Detection Range:	240~960MHz
Input Frequency Detection Bandwidth:	1~720MHz
Input Frequency Step:	1MHz
Spectrum Dynamic range:	90dB
Amplitude Range:	+10~-110dBm
Display:	TFT
Input Interface:	SMA female
Current Consumption:	65mA
Built-in Power Supply:	Built-in 3.7V/1000mA lithium battery
Charging Interface:	TYPE-C standard USB 5V charging
Working Temperature:	0°C to +45°C
Dimensions(mm):	72 (W)× 23 (D)×204.5 (H) (*Without antenna 108)
Weight:	150g

U.Discover

Portable Spectrum Analyzer

Software Interface

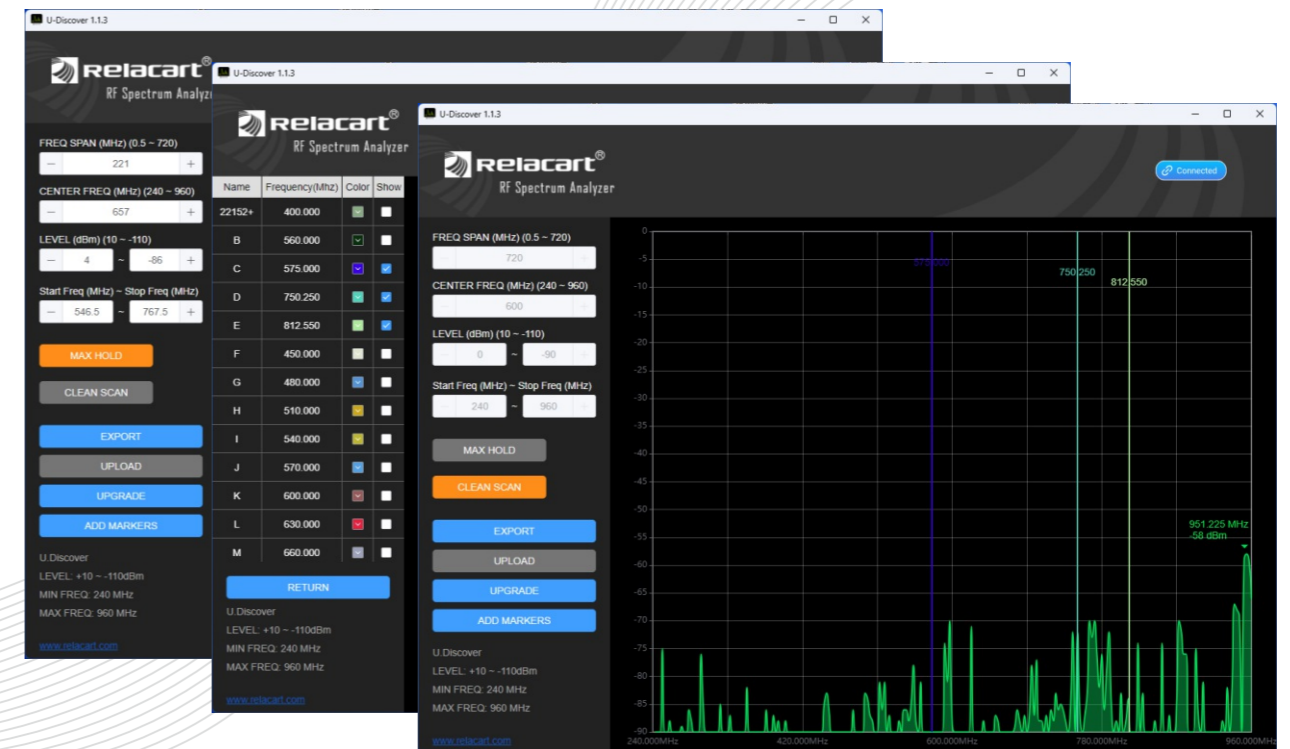

Key Features

Compact and portable

- The overall shape is exquisite and compact, and can be carried in a backpack to create a stable wireless working environment anytime and anywhere.

Frequency visualization

- Can detect frequency details in the range of 240MHz-960MHz and display them on a clear and bright screen, enabling detection of on-site wireless working environments.



SA-960 is a spectrum analyzer specially developed for wireless frequency management. The frequency is visualized and controllable, creating a stable wireless working environment for the scene. The ultra-wideband scheme is adopted, and the frequency scan is up to 960MHz, the on-site interference frequency is clear.

Product Specification



SA-960
Wireless Spectrum Analyzer

Main Frame Size:	EIA Standard Rack 1U
Frequency Range:	240MHz-960MHz
Step Frequency:	1-720MHz
Amplitude Range:	+10~ -110dBm
Interface:	BNC
Power Supply:	DC 12V /1000mA
Dimensions(mm):	410(W)×206(D)×43(H)
Weight:	About 2Kg

Software Interface

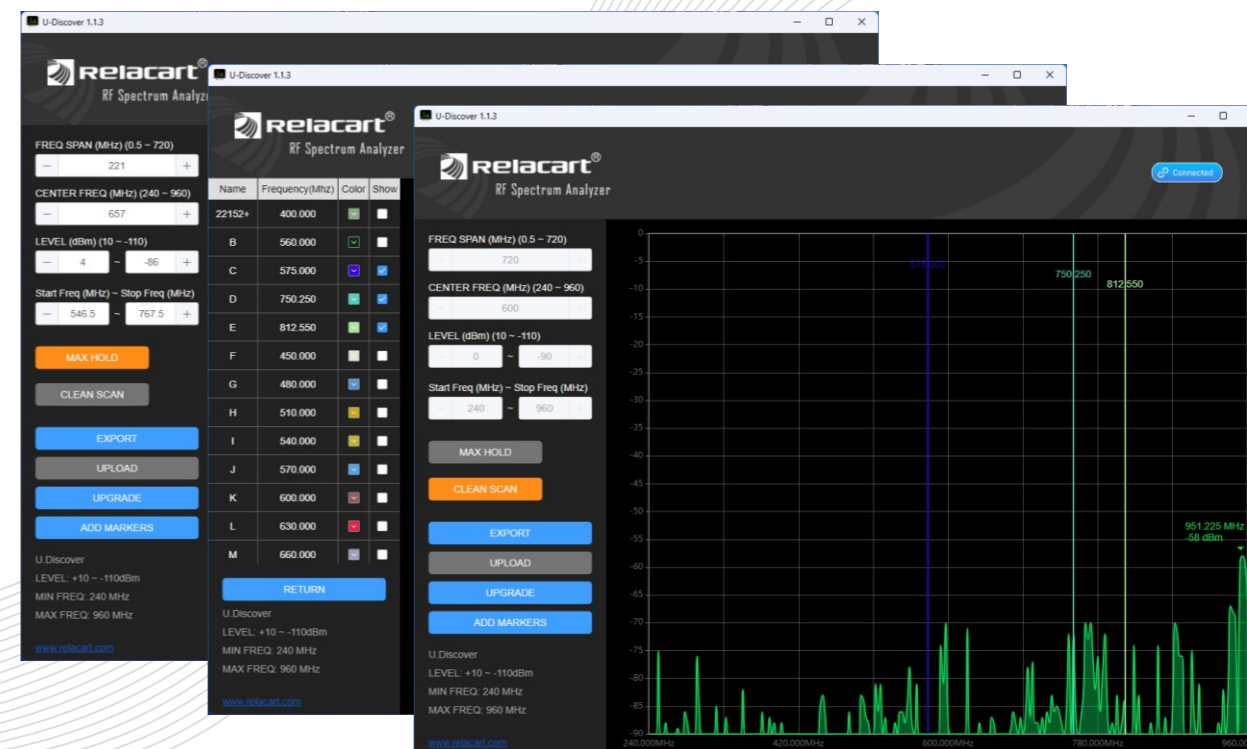

Display overview

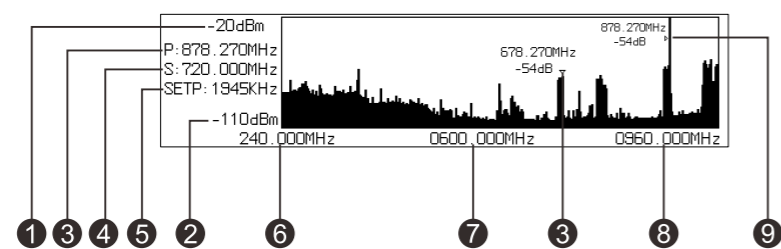

- ① The highest point of the peak level.
- ② The lowest point of the peak level.
- ③ PEAK frequency value.
- ④ SPAN: Current frequency bandwidth value.
- ⑤ SETP: Each step frequency display.
- ⑥ Start frequency display.
- ⑦ Center frequency display.
- ⑧ End frequency display.
- ⑨ Move the cursor and display the current frequency and level of the cursor.

UR-2Q

QUAD CHANNEL 130MHz WIDEBAND
TRUE DIVERSITY WIRELESS MICROPHONE



UR-2Q series wireless microphone cohesive Relacart long-term accumulation of technical essence, with advanced four-channel electrical tuning technology, 130MHz switching bandwidth (depending on the region); has a beautiful industrial design appearance; with independent research and development of DSP audio expansion algorithm Support Dante protocol output, Magic EQ function can be adjusted freely; this series is suitable for high-demand nightclubs, multi-purpose demonstration halls, hotels, conferences and small and medium-sized performances.

Product Specification



UR-2Q

Quad Channel Wireless Receiver

- The 1U metal chassis of the international EIA standard is adopted. It is elegant with novel, concise and ultra wide angle OLED liquid crystal display and visualized LED.
- Receiver bright OLED display, can display the working channel or frequency, receiver name, transmitter battery capacity, visual LED display RF and AF signal strength.
- Built in antenna distribution system.

Main Frame Size:	EIA Standard Rack 1U
Frequency Stability:	±0.005%
External Antenna:	Dual BNC support
Interface:	+12V/150mA output
External Audio Interface:	Mixed balanced audio output, BALANCED single channel balanced audio output
Ethernet Port:	Support Dante communication protocol
Carrier Frequency Range:	470MHz-960MHz
Oscillation:	PLL synthesized
Sensitivity:	5dBu, S/N>60dB at 25KHz deviation
Bandwidth:	130MHz
Max. Deviation Range:	±45KHz
Audio Sampling Rate:	96KHz 24-bit
Audio Expansion:	Relacart DSP Digital Audio Extension Algorithm
S/N:	>105dB
T.H.D:	<0.7%@1KHz
Frequency Response:	80Hz~18KHz ±3dB
Operation Range With Line of Sight Approx:	80 meters
Power Supply:	AC input, ICE connector, 100-240 VAC
Dimensions(mm):	480(W)×350(D)×43(H)

Key Features



Dante Network Audio Protocol

- With Dante network audio output, Dante audio device can automatically identify the Dante channel of the product; audio signal can be output to any Dante audio device.



[Magic EQ] Function

- It built-in 9 kinds of digital audio equalizers (Magic EQ), which can directly change the audio quality curve through parameters.



IR Infrared Counter-Frequency

- With [IR] infrared automatic frequency matching function, press the [SYNC] button, the transmitter can automatically and lock on to an open accurately.



Energy Conservation

- Precise low-consumption circuit design, use two AA alkaline battery, the battery life is twice as common.



DSP Audio Digital Extension

- High-speed DSP chip, 24-bit high-performance ADC, DAC plus self-developed digital audio expansion algorithm to minimize the noise caused by wireless transmission.



Automatic Frequency Selection (AFS)

- With [AFS] (Auto Frequency Selection) function, enter the setup menu and select AFS function, the receiver will auto-scan and lock on to an open interference-free frequency.



Ultra Wide Bandwidth

- Ultra-wideband UHF 470MHz ~ 960MHz, pure diversity reception; each channel division and frequency design, to ensure the most wireless microphones can be used simultaneously in the narrowest frequency range.



Universal Property

- 134MHz wideband transmitter, multiple receivers in different frequency bands are free to use.



UH-2

Wireless Handheld Microphone

- Handheld wireless microphone, simple design style, durable metal material, high contrast OLED display, built-in gain adjustment function, humanized mechanical switch, microphone module design, and a variety of characteristics of the sound head module can be matched, suitable for speech, singing and other occasions.

Carrier Frequency Range :	470MHz-960MHz
Harmonic Radiation :	<45dBm
Bandwidth :	Single-band 134MHz
Modulation Mode :	FM
Audio Compression :	Relacart classic audio compression circuit
Capsule :	Dynamic or Condenser, Cardioid
RF Power Output :	10mW/30mW
Battery :	AA ×2
Current Consumption :	130mA(typical)
Battery Life :	Approximately 8 hours
Dimensions(mm) :	52(Φ)×255(L)
Weight (without battery) :	Approximately 235g



UT-2

Wireless Bodypack Transmitter

- Contracted design style, solid and dural metal material, high contrast OLED display. Built-in gain adjustment function.
- Standard Mini XLR microphone interface, suitable for the headset mic and clip mic of a variety of well-known brand in the market. Suitable for application in speech, singing and other occasions

Carrier Frequency Range:	470MHz-960MHz
Harmonic radiation:	<45dBm
Bandwidth:	Single-band 134MHz
Modulation Mode:	FM
Audio compression:	Relacart classic audio compression circuit
Input Connector:	4-pin mini-XLR connector, Input gain 3 levels adjustable
RF Power Output:	10mW / 30mW
Battery:	AA ×2
Current Consumption:	130mA(typical)
Battery life:	Approximately 8 hours
Dimensions(mm):	84(H)×66(W)×23(D)
Weight (without battery):	Approximately 155g



UB-943

Wireless Array Microphone

- The wireless array microphone adopts a metal streamlined desktop design with OLED display.
- The array microphone has an ultra-long pickup distance of 80CM and a deeper pickup range, and its directional characteristics are significantly improved compared to ordinary cardioid microphones.

Carrier Frequency Range:	521.25MHz ~ 936.85MHz
Oscillation Mode:	PLL synthesized
Bandwidth:	134MHz
Max. Deviation:	±45KHz
RF Output Power:	30mW
Power Supply:	Lithium-ion polymer rechargeable battery

UR-280 | DUAL-CHANNEL TRUE DIVERSITY WIRELESS MICROPHONE SYSTEM



UR-280 is a dual-channel true diversity wireless microphone system condensed from the essence of Relacart's many years of technology. It has advanced technology, stable performance and exquisite design. The bandwidth is up to 64MHz, wider than similar products on the market, with more frequency to choose from; the volume is adjustable in 1dB step, three levels of RF power are optional, multi-level SQ is optional, and a handheld microphone charging base is optional. It is more convenient; the 1.14-inch TFT color display has higher display quality. It is fully suitable for high-demand business negotiation venues, multi-functional halls, hotels, conference rooms and small to medium-sized performance venues.

Key Features

SQ multi-level adjustable

The multi-level SQ value can be adjusted freely, and the mute threshold can be adjusted according to the actual use situation on site. It can ensure high-quality sound pickup regardless of short distance or long distance, and can be used in various occasions.

RF power multi-level adjustable

The RF power is available in three levels: high, medium, low. Compared with other products on the market, there are more choices. Short-distance transmission can reduce power consumption, and it can also easily handle situations where long-distance transmission is required.

Optional dual-bay chargers

Optional contact-type dual bay charger, simply place the microphone into it for charging. Utilizing rechargeable NiMH batteries, it offers a longer lifespan compared to alkaline batteries, ensuring enhanced safety, durability, and environmental friendliness. This convenient charging method is suitable for various scenarios requiring frequent charging.

64MHz ultra-wide bandwidth

The system has an ultra-wide bandwidth of 64MHz, which is wider than similar products on the market. Even when multiple sets of equipment are needed for large-scale performances, there are still enough frequencies to choose from, making it easier to avoid interference during use.

TFT display screen

It adopts a 1.14-inch TFT high-brightness display with rich colors and high visibility. It is easy to grasp the working status of the device and clearly displays the frequency, power, dB value, lock/unlock and other status.

Anti-accidental touch switch

The handheld microphone uses a toggle switch and is located at the tail to prevent accidentally touching the switch during use, which may cause interruptions in performances, meetings, etc.

Product Specification



UR-280
Dual Channel Wireless Receiver

Chassis specification:	EIA standard 1U
Receiving channel:	Dual channel
Frequency stability:	± 0.005%
Carrier frequency band:	521.25MHz-936.85MHz
Modulation method:	FM
Oscillation mode:	PLL frequency synthesis technology
Sensitivity:	When the offset is equal to 25KHz and 5dBuV is input, S/N>60dB
Band width:	64MHz (depending on region)
Maximum offset:	± 45KHz
Comprehensive S/N ratio:	>110dB
Comprehensive T.H.D.:	<0.5% @ 1KHz
Frequency response:	50Hz-18KHz ± 1dB
Effective working distance:	generally 100 meters (wide range)
Power supply:	DC12V/1A
Dimensions (mm):	410 (L) × 206 (W) × 43 (H)
Antenna interface:	Dual BNC supports+12V/150mA
Output audio interface:	6.3mm unbalanced audio output, XLR balanced audio output
Weight:	Approximately 2kg



UH-280
Wireless Handheld Microphone

Equipped with a 1.14-inch color TFT screen, clearly display status of frequency group, frequency band, battery level, dB value, lock/unlock, etc. Powered by two pc of AA battery or NiMH battery. It can be put in the dual-bay charger for charging when adopt NiMH battery. It is suitable for various occasions that require frequent charging.

Carrier Frequency Range:	521.25MHz~936.85MHz
Harmonic Radiation:	<45dBm lower than the main wave
Bandwidth:	Single channel 134MHz (depending on the region)
Modulation:	FM
Capsule:	Dynamic
RF Output Power:	high, medium, low
Volume Adjustment:	-15~+5dB, 1dB step
Battery:	AA×2
Current Consumption:	170mA(Typical)
Battery Current/ Life:	Approximately 8 hours(alkaline)
Dimension(mm):	55(Φ) ×269(L)



UT-280
Wearable Bodypack Transmitter

It's a mini wearable bodypack transmitter with a compact appearance, light weight and durability. Equipped with a 4-pin mini XLR input port, can connect an external microphone. Powered by one pc of AA battery or NiMH battery. It can be put in the dual-bay charger for charging when adopt NiMH battery. It is suitable for speeches, meetings, education, performances and other occasions.

Carrier Frequency Range:	521.25MHz~936.85MHz
Oscillation:	PLL synthesized
Harmonic Radiation:	<45dBm lower than the main wave
Max. Deviation:	±45KHz
Input Connector:	4-pin mini XLR connector
RF Output Power:	high, medium, low
Volume Adjustment:	-15~+5dB, 1dB step
Battery:	AA×2
Current Consumption:	170mA(Typical)
Battery Current/ Life:	Approximately 8 hours(alkaline)
Dimension(mm):	65(W)×21.3(D)×75.5(H)



RC-2
Dual-bay Charger

Dual Bay Charger is suitable for Relacart rechargeable handheld transmitters and bodypack transmitters. Just put the transmitters into it for charging. It can display the current device power and has a charging completion indicator light.

Compatible transmitters:	Up to 2 × UH-280, UT-280, BG-24H, or BG-24T
Compatible transmitter charging parameters:	
Charging current:	Fast charge 1.1 A; slow charge 500 mA
Charging time:	3 hours = 50% charged; 6 hours = 100% charged (battery capacity: 2600 mAh)
External power supply:	DC 12V / 1A (maximum of 4 units can be connected in daisy chain)
External power supply required when connected in daisy chain:	12V / 2A (2 units) 12V / 3A (3 units) 12V / 4A (4 units)
Compatible SONY camera battery charging parameters:	
Charging current:	600 mA
Charging time:	1.5 hours = 50% charged; 3 hours = 100% charged (battery capacity: 1500 mAh)
Operating temperature range:	-18°C (0°F) to 50°C (122°F)
Storage temperature range:	-29°C (-20°F) to 74°C (165°F)
Dimensions (mm):	185 (W) × 88 (D) × 86 (H)
Weight:	Approx. 155 g

UR-290 | DUAL-CHANNEL TRUE DIVERSITY WIRELESS MICROPHONE SYSTEM



UR-290 is a dual-channel true diversity wireless microphone system condensed from the essence of Relacart's many years of technology. It has advanced technology, stable performance and exquisite design. It can be connected to MagicEQ professional audio software for adjustment. The bandwidth is up to 64MHz, wider than similar products on the market, with more frequency to choose from; the volume is adjustable in 1dB step, three levels of RF power are optional, multi-level SQ is optional, and a handheld microphone charging base is optional. It is more convenient; the 1.14-inch TFT color display has higher display quality. It is fully suitable for high-demand business negotiation venues, multi-functional halls, hotels, conference rooms and small to medium-sized performance venues.

Key Features

MagicEQ™

- The connection software has a built-in digital equalization processor, with 9 tone modes to choose from, 7 of which are fixed modes, covering various international brand tone effects, and 2 custom modes. The tone can be adjusted freely through dedicated operating software to achieve individual needs, desired effect.

SQ multi-level adjustable

- The multi-level SQ value can be adjusted freely, and the mute threshold can be adjusted according to the actual use situation on site. It can ensure high-quality sound pickup regardless of short distance or long distance, and can be used in various occasions.

RF power multi-level adjustable

- The RF power is available in three levels: high, medium, low. Compared with other products on the market, there are more choices. Short-distance transmission can reduce power consumption, and it can also easily handle situations where long-distance transmission is required.

Optional dual-bay chargers

- Optional contact-type dual bay charger, simply place the microphone into it for charging. Utilizing rechargeable NiMH batteries, it offers a longer lifespan compared to alkaline batteries, ensuring enhanced safety, durability, and environmental friendliness. This convenient charging method is suitable for various scenarios requiring frequent charging.

64MHz ultra-wide bandwidth

- The system has an ultra-wide bandwidth of 64MHz, which is wider than similar products on the market. Even when multiple sets of equipment are needed for large-scale performances, there are still enough frequencies to choose from, making it easier to avoid interference during use.

TFT display screen

- It adopts a 1.14-inch TFT high-brightness display with rich colors and high visibility. It is easy to grasp the working status of the device and clearly displays the frequency, power, dB value, lock/unlock and other status.

FBK Feedback Suppression Function

- It has the domestically pioneered FBK function, which can automatically and effectively prevent howling, enabling the singer to achieve a perfect performance.

Product Specification



UR-290
Dual Channel Wireless Receiver

Chassis specification:	EIA standard 1U
Receiving channel:	Dual channel
Frequency stability:	± 0.005%
Carrier frequency band:	521.25MHz-936.85MHz
Modulation method:	FM
Oscillation mode:	PLL frequency synthesis technology
Sensitivity:	When the offset is equal to 25KHz and 5dBuV is input, S/N>60dB
Band width:	64MHz (depending on region)
Maximum offset:	± 45KHz
Comprehensive S/N ratio:	>110dB
Comprehensive T.H.D.:	<0.5% @ 1KHz
Frequency response:	50Hz-18KHz ± 1dB
Effective working distance:	generally 100 meters (wide range)
Power supply:	DC12V/1A
Dimensions (mm):	410 (L) × 206 (W) × 43 (H)
Antenna interface:	Dual BNC supports+12V/150mA
Output audio interface:	6.3mm unbalanced audio output, XLR balanced audio output
Sampling rate:	96K
Weight:	Approximately 2kg



UH-280
Wireless Handheld Microphone

- Equipped with a 1.14-inch color TFT screen, clearly display status of frequency group, frequency band, battery level, dB value, lock/unlock, etc. Powered by two pc of AA battery or NiMH battery. It can be put in the dual-bay charger for charging when adopt NiMH battery. It is suitable for various occasions that require frequent charging.

Carrier Frequency Range:	521.25MHz~936.85MHz
Harmonic Radiation:	<45dBm lower than the main wave
Bandwidth:	Single channel 134MHz (depending on the region)
Modulation:	FM
Capsule:	Dynamic
RF Output Power:	high, medium, low
Volume Adjustment:	-15~+5dB, 1dB step
Battery:	AA×2
Current Consumption:	170mA(Typical)
Battery Current/ Life:	Approximately 8 hours(alkaline)
Dimension(mm):	55(Φ) × 269(L)



UT-280
Wearable Bodypack Transmitter

- It's a mini wearable bodypack transmitter with a compact appearance, light weight and durability. Equipped with a 4-pin mini XLR input port, can connect an external microphone. Powered by one pc of AA battery or NiMH battery. It can be put in the dual-bay charger for charging when adopt NiMH battery. It is suitable for speeches, meetings, education, performances and other occasions.

Carrier Frequency Range:	521.25MHz~936.85MHz
Oscillation:	PLL synthesized
Harmonic Radiation:	<45dBm lower than the main wave
Max. Deviation:	±45KHz
Input Connector:	4-pin mini XLR connector
RF Output Power:	high, medium, low
Volume Adjustment:	-15~+5dB, 1dB step
Battery:	AA×2
Current Consumption:	170mA(Typical)
Battery Current/ Life:	Approximately 8 hours(alkaline)
Dimension(mm):	65(W)×21.3(D)×75.5(H)



RC-2
Dual-bay Charger

- Dual Bay Charger is suitable for Relacart rechargeable handheld transmitters and bodypack transmitters. Just put the transmitters into it for charging. It can display the current device power and has a charging completion indicator light.

Compatible transmitters:	Up to 2 × UH-280, UT-280, BG-24H, or BG-24T
Compatible transmitter charging parameters:	
Charging current:	Fast charge 1.1 A; slow charge 500 mA
Charging time:	3 hours = 50% charged; 6 hours = 100% charged (battery capacity: 2600 mAh)
External power supply:	DC 12V / 1A (maximum of 4 units can be connected in daisy chain)
External power supply required when connected in daisy chain:	12V / 2A (2 units) 12V / 3A (3 units) 12V / 4A (4 units)
Compatible SONY camera battery charging parameters:	
Charging current:	600 mA
Charging time:	1.5 hours = 50% charged; 3 hours = 100% charged (battery capacity: 1500 mAh)
Operating temperature range:	-18°C (0°F) to 50°C (122°F)
Storage temperature range:	-29°C (-20°F) to 74°C (165°F)
Dimensions (mm):	185 (W) × 88 (D) × 86 (H)
Weight:	Approx. 155 g

UR-290D | DUAL-CHANNEL TRUE DIVERSITY WIRELESS MICROPHONE SYSTEM



Dante

UR-290D is a dual-channel true diversity wireless microphone system condensed from the essence of Relacart's many years of technology. It has advanced technology, stable performance and exquisite design. It supports Dante audio transmission protocol and can be connected to MagicEQ professional audio software for adjustment. The bandwidth is up to 64MHz, wider than similar products on the market, with more frequency to choose from; the volume is adjustable in 1dB step, three levels of RF power are optional, multi-level SQ is optional, and a handheld microphone charging base is optional. It is more convenient; the 1.14-inch TFT color display has higher display quality. It is fully suitable for high-demand business negotiation venues, multi-functional halls, hotels, conference rooms and small to medium-sized performance venues.

Key Features

Dante Dante network audio protocol

- Supports the Dante network audio protocol, which has the characteristics of low latency, high precision, low cost, and uncompressed audio signals. At the same time, it only needs one network cable to connect to other Dante devices, solving the complex wiring problems in traditional audio transmission. Makes system expansion extremely easy.

MagicEQ™

- The connection software has a built-in digital equalization processor, with 9 tone modes to choose from, 7 of which are fixed modes, covering various international brand tone effects, and 2 custom modes. The tone can be adjusted freely through dedicated operating software to achieve individual needs, desired effect.

SQ multi-level adjustable

- The multi-level SQ value can be adjusted freely, and the mute threshold can be adjusted according to the actual use situation on site. It can ensure high-quality sound pickup regardless of short distance or long distance, and can be used in various occasions.

RF power multi-level adjustable

- The RF power is available in three levels: high, medium, low. Compared with other products on the market, there are more choices. Short-distance transmission can reduce power consumption, and it can also easily handle situations where long-distance transmission is required.

64MHz ultra-wide bandwidth

- The system has an ultra-wide bandwidth of 64MHz, which is wider than similar products on the market. Even when multiple sets of equipment are needed for large-scale performances, there are still enough frequencies to choose from, making it easier to avoid interference during use.

TFT TFT display screen

- It adopts a 1.14-inch TFT high-brightness display with rich colors and high visibility. It is easy to grasp the working status of the device and clearly displays the frequency, power, dB value, lock/unlock and other status.

FBK Feedback Suppression Function

- It has the domestically pioneered FBK function, which can automatically and effectively prevent howling, enabling the singer to achieve a perfect performance.

Optional dual-bay chargers

- Optional contact-type dual bay changer, simply place the microphone into it for charging. Utilizing rechargeable NiMH batteries, it offers a longer lifespan compared to alkaline batteries, ensuring enhanced safety, durability, and environmental friendliness. This convenient charging method is suitable for various scenarios requiring frequent charging.

Product Specification



UR-290D
Dual Channel Wireless Receiver

Chassis specification:	EIA standard 1U
Receiving channel:	Dual channel
Frequency stability:	± 0.005%
Carrier frequency band:	521.25MHz-936.85MHz
Modulation method:	FM
Oscillation mode:	PLL frequency synthesis technology
Sensitivity:	When the offset is equal to 25KHz and 5dBuV is input, S/N>60dB
Band width:	64MHz (depending on region)
Maximum offset:	± 45KHz
Comprehensive S/N ratio:	>110dB
Comprehensive T.H.D.:	<0.5% @ 1KHz
Frequency response:	50Hz-18KHz ± 1dB
Effective working distance:	generally 100 meters (wide range)
Power supply:	DC12V/1A
Dimensions (mm):	410 (L) × 206 (W) × 43 (H)
Antenna interface:	Dual BNC supports+12V/150mA
Output audio interface:	6.3mm unbalanced audio output, XLR balanced audio output
Interface:	Dante Network Protocol
Weight:	Approximately 2kg



UH-280
Wireless Handheld Microphone

- Equipped with a 1.14-inch color TFT screen, clearly display status of frequency group, frequency band, battery level, dB value, lock/unlock, etc. Powered by two pc of AA battery or NiMH battery. It can be put in the dual-bay charger for charging when adopt NiMH battery. It is suitable for various occasions that require frequent charging.

Carrier Frequency Range:	521.25MHz~936.85MHz
Harmonic Radiation:	<45dBm lower than the main wave
Bandwidth:	Single channel 134MHz (depending on the region)
Modulation:	FM
Capsule:	Dynamic
RF Output Power:	high, medium, low
Volume Adjustment:	-15~+5dB, 1dB step
Battery:	AA×2
Current Consumption:	170mA(Typical)
Battery Current/ Life:	Approximately 8 hours(alkaline)
Dimension(mm):	55(Φ) ×269(L)



UT-280
Wearable Bodypack Transmitter

- It's a mini wearable bodypack transmitter with a compact appearance, light weight and durability. Equipped with a 4-pin mini XLR input port, can connect an external microphone. Powered by one pc of AA battery or NiMH battery. It can be put in the dual-bay charger for charging when adopt NiMH battery. It is suitable for speeches, meetings, education, performances and other occasions.

Carrier Frequency Range:	521.25MHz~936.85MHz
Oscillation:	PLL synthesized
Harmonic Radiation:	<45dBm lower than the main wave
Max. Deviation:	±45KHz
Input Connector:	4-pin mini XLR connector
RF Output Power:	high, medium, low
Volume Adjustment:	-15~+5dB, 1dB step
Battery:	AA×2
Current Consumption:	170mA(Typical)
Battery Current/ Life:	Approximately 8 hours(alkaline)
Dimension(mm):	65(W)×21.3(D)×75.5(H)



RC-2
Dual-bay Charger

- Dual Bay Charger is suitable for Relacart rechargeable handheld transmitters and bodypack transmitters. Just put the transmitters into it for charging. It can display the current device power and has a charging completion indicator light.

Compatible transmitters:	Up to 2 × UH-280, UT-280, BG-24H, or BG-24T
Compatible transmitter charging parameters:	
Charging current:	Fast charge 1.1 A; slow charge 500 mA
Charging time:	3 hours = 50% charged; 6 hours = 100% charged (battery capacity: 2600 mAh)
External power supply:	DC 12V / 1A (maximum of 4 units can be connected in daisy chain)
External power supply required when connected in daisy chain:	12V / 2A (2 units) 12V / 3A (3 units) 12V / 4A (4 units)
Compatible SONY camera battery charging parameters:	
Charging current:	600 mA
Charging time:	1.5 hours = 50% charged; 3 hours = 100% charged (battery capacity: 1500 mAh)
Operating temperature range:	-18°C (0°F) to 50°C (122°F)
Storage temperature range:	-29°C (-20°F) to 74°C (165°F)
Dimensions (mm):	185 (W) × 88 (D) × 86 (H)
Weight:	Approx. 155 g

UR-223D

DUAL-CHANNEL TRUE DIVERSITY WIRELESS MICROPHONE SYSTEM



UR-223D is a dual channel true diversity wireless microphone system. The true diversity reception is more stable, with automatic dispatch, eliminate receive dead Angle, avoid fault frequency phenomenon. UR-223D with advanced technology, stable performance, exquisite appearance, convenient operation and superior professional quality to win the market. This series is suitable for high requirement night club, multi-function room, hotels, and conference room and medium to large performance.

Product Specification



UR-223D
Dual Channel Wireless Receiver

- EIA Standard Rack 1U metal chassis, combined with novel compact LCD display.
- The receiver with ultra wide reviewing angle LCD display, shows working channel/frequency, RF/AF, transmitter battery level, mute and other status. And built-in electronic volume.

Main Frame Size:	EIA Standard Rack 1U
Channels:	Dual Channel
Frequency Stability:	±0.005% (-10°C~50°C)
Carrier Frequency Range:	521.25MHz~936.85MHz
Modulation Mode:	FM
Oscillation:	PLL synthesized
Receiving Sensitivity:	S/N>60dB at 25 deviation
Bandwidth:	64MHz
Antenna Connector:	BTC
Max. Deviation Range:	±45KHz
S/N:	>105dB
T.H.D.:	<0.7%@1KHz
Frequency Response:	80Hz-18KHz ±3dB
Operating Range:	80M typical (in open space)
Power Supply:	DC 12V / 12W
Companding:	Relacart classical audio processing technology
Output Connector:	XLR balanced & 6.3φ phone jack unbalanced
Dimension (mm):	410(W)×206(D)×43(H)
Weight:	Approximately1.9kg

Key Features

Wide range of audio outputs

- It adopts 6.3mm unbalanced output and XLR balanced output synchronous output design, which is convenient to connect various audio processing equipment.

Super Wide Frequency Range

- Super wide frequency range 521.25-936.85MHz, with AFS function, dual channel receiving circuit of true diversity reception.

AFS(Automatic Frequency Selection)

- Press the "AFS" (Auto Frequency Selection) button 3 sec and the receiver will auto-scan and lock on to an open, interference-free frequency.

PLL PLL Phase Locked Oscillation Circuit

- The stable PLL phase-locked oscillation circuit, combined with the "digital pilot" mute control function and the "noise detection" mute control function, can effectively block the noise and radio frequency interference of computer equipment, karaoke machines and DVDs in the working environment.

IR Infrared

- Press [IR] button to upload automatically the receiver frequency to the transmitter.

True diversity reception

- The true diversity receiving system uses two receiving circuits with the same channel to reduce the noise and sound leakage caused by radio frequency interference.



UH-222
Wireless Handheld Microphone

- Handheld wireless microphone, simple design style, durable metal material, high contrast OLED display, built-in gain adjustment function, mute switch (optional mechanical switch). Microphone modular design, and various features of the capsule module optional, suitable for various occasions such as speech, singing, etc.

Carrier Frequency Range:	470MHz~936.85MHz
Oscillation:	PLL Synthesized
Harmonic Radiation:	<45dBm
Bandwidth:	134MHz(It depends on the region)
Max. Deviation Range:	±45KHz
Microphone Element:	Dynamic/Condenser(removable)
RF Output Power:	20mW/2mW
Battery:	Aax2
Current Consumption:	110mA(Typical)
Battery Current/ Life:	Approximately 11 hours
Microphone Lengths(mm):	52(Φ)×255(L)
Weight(w/o battery):	Approximately 235g



UT-222
Wireless Bodypack Transmitter

- bodypack-style wireless microphone, simple design, lightweight and practical engineering materials, durable, multi-function OLED display, built-in input selector switch, can be used to facilitate the instrument. The standard mini XLR microphone interface is suitable for a variety of well-known headset and clip microphones on the market. It is suitable for applications such as speech and singing.

Carrier Frequency Range:	470MHz~936.85MHz
Oscillation:	PLL Synthesized
Harmonic Radiation:	<45dBm
Bandwidth:	134MHz(It depends on the region)
Max. Deviation Range:	±45KHz
Input Connector:	4-pin mini-XLR connector
RF Output Power:	20mW/2mW
Battery:	Aax2
Current Consumption:	110mA(Typical)
Battery Current/ Life:	Approximately 11 hours
Microphone Lengths(mm):	84(H)×66(W)×23(D)
Weight(w/o battery):	Approximately 155g

UR-223S

SINGLE-CHANNEL TRUE DIVERSITY
WIRELESS MICROPHONE SYSTEM



UR-223S series of condensed the technology essence that Relacart accumulated over a long period. With advanced technology, stable performance, elaborate appearance, convenient operation and superior professional quality to win the market. This series is suitable for high requirement night club, multi-function room, hotels, conference room and small to medium performance.

Product Specification



UR-223S

Single Channel Wireless Receiver

- 1U Half-Rack metal rack receiver chassis, offering new style and simple LCD display;
- Bright LCD display can simultaneously display the working channel or frequency, RF & AF signal status, transmitter battery consumption as well as mute level.

Main Frame Size:	1U Half-Rack
Channels:	Single Channel
Frequency Stability:	±0.005% (-10°C~50°C)
Carrier Frequency Range:	521.25MHz~936.85MHz
Modulation Mode:	FM
Oscillation:	PLL synthesized
Receiving Sensitivity:	5dBμV, S/N>60dB at 25 deviation
Bandwidth:	32MHz
Max. Deviation Range:	±45KHz
S/N:	>105dB
T.H.D.:	<0.7%@1KHz
Frequency Response:	80Hz-18KHz ±3dB
Operating Range:	60M typical (in open space)
Power Supply:	DC 12~18V/1A
Output Connector:	XLR balanced & 6.3φ phone jack unbalanced
Dimension (mm):	205(W)×206(D)×43(H)
Weight:	Approximately 1.0kg

Key Features

Wide range of audio outputs

- It adopts 6.3mm unbalanced output and XLR balanced output synchronous output design, which is convenient to connect various audio processing equipment.

AFS(Automatic Frequency Selection)

- With the [AFS] function of automatically searching for clean and non-interfering frequencies in the actual environment, after long pressing the ▲ button or the ▼ button for 3 seconds, it will automatically search and lock on the channel without interference in the actual working environment.

IR Infrared

- Press [IR] button to upload automatically the receiver frequency to the transmitter.

Flexibility

- The handheld microphone: novel design, OLED display screen, showing battery level, working channel and frequency. The tube is made by durable alloy, effectively protecting the circuit element and battery rack, and with ergonomic grip.
- The new optimized circuit design, good sound quality, transmission distance is longer and more stable
- The capsule of handheld microphone can be removed and replaced, and the condenser or dynamic capsule can be used. It's compatible with SHURE SM-58 capsule. Using 6.3 mm unbalanced output and XLR balanced output synchronization output design, convenient to connect all kinds of audio processing equipment

Dual Squelch Lock

- Adopt noise locking and field strength locking double squelch locking circuit design, effectively prevent the radio frequency interference of other microphones, and improve the signal-to-noise ratio.

Super Wide Frequency Range

- Super wide frequency range UHF522MHz~936MHz, automatic selection, true diversity reception of dual-channel receiving circuit. The true diversity receiving system uses two receiving circuits with the same channel to reduce the noise and sound leakage caused by radio frequency interference.

PLL PLL Phase Locked Oscillation Circuit

- The stable PLL phase-locked oscillation circuit, combined with the "digital pilot" mute control function and the "noise detection" mute control function, can effectively block the noise and radio frequency interference of computer equipment, karaoke machines and DVDs in the working environment.



UH-222

Wireless Handheld Microphone



UT-222

Wireless Bodypack Transmitter

- Handheld wireless microphone, simple design style, durable metal material, high contrast OLED display, built-in gain adjustment function, mute switch (optional mechanical switch). Microphone modular design, and various features of the capsule module optional, suitable for various occasions such as speech, singing, etc.

Carrier Frequency Range:	470MHz~936.85MHz
Oscillation:	PLL Synthesized
Harmonic Radiation:	<45dBm
Bandwidth:	134MHz(It depends on the region)
Max. Deviation Range:	±45KHz
Microphone Element:	Dynamic/Condenser(removable)
RF Output Power:	20mW/2mW
Battery:	Aax2
Current Consumption:	110mA(Typical)
Battery Current/ Life:	Approximately 11 hours
Microphone Lengths(mm):	52(Φ)×255(L)
Weight(w/o battery):	Approximately 235g

- bodypack-style wireless microphone, simple design, lightweight and practical engineering materials, durable, multi-function OLED display, built-in input selector switch, can be used to facilitate the instrument. The standard mini XLR microphone interface is suitable for a variety of well-known headset and clip microphones on the market. It is suitable for applications such as speech and singing.

Carrier Frequency Range:	470MHz~936.85MHz
Oscillation:	PLL Synthesized
Harmonic Radiation:	<45dBm
Bandwidth:	134MHz(It depends on the region)
Max. Deviation Range:	±45KHz
Input Connector:	4-pin mini-XLR connector
RF Output Power:	20mW/2mW
Battery:	Aax2
Current Consumption:	110mA(Typical)
Battery Current/ Life:	Approximately 11 hours
Microphone Lengths(mm):	84(H)×66(W)×23(D)
Weight(w/o battery):	Approximately 155g

UR-260D

DUAL-CHANNEL ANTENNA DIVERSITY WIRELESS MICROPHONE SYSTEM



UR-260D series cohesion Relacart long-term accumulation of technology essence. With advanced technology, stable performance, elaborate appearance, convenient operation, and superior professional quality to win the market. This series is suitable for high requirement large scale professional tours.

Key Features

FBK "Feedback Killer"

- "Feedback Killer" automatic feedback extermination, providing maximum gain and increased clarity on every microphone.

MagicEQ™

- Built-in 9 kinds of MagicEQ™ Built-in MagicEQ™ preset and user-defined microphone capsule equalization for faithful reproduction to the vocalist or speaker's favorite "personality" sound.

AFS(Automatic Frequency Selection)

- Press the "AFS" (Auto Frequency Selection) button 3 sec and the receiver will auto-scan and lock on to an open, interference-free frequency.

IR Infrared

- Press [IR] button to upload automatically the receiver frequency to the transmitter.

Super Wide Frequency Range

- Super wide frequency range UHF554MHz~936 MHz, Auto Frequency Selection, CPU Intelligent Antenna Diversity.

Univesal Propergy

- 134MHz transmitter, specially designed for capable of full frequency range transmission.

PLL Phase Lock Loop Frequency Control

- PLL(Phase Lock Loop frequency control) design ensures transmission reliability, "NoiseLock" squelch effectively blocks stray RF.

Intelligent Management

- The receiver can be connected computer via TCP/IP or connected Android phone via WIFI, realizing remote control, remote diagnostics and upgrades.

Product Specification



UR-260D

Dual Channel Wireless Receiver

- EIA Standard Rack 1U metal rack receiver chassis, offering new style and simple LCD display;
- Bright LCD display can simultaneously display the working channel or frequency, RF & AF signal status, transmitter battery consumption as well as mute level.

Main Frame Size:	EIA Standard Rack 1U
Channels:	Dual Channel
Frequency Stability:	±0.005% (0~50°C)
Carrier Frequency Range:	521.25MHz~936.85MHz
Modulation Mode:	FM
Oscillation:	PLL synthesized
Receiving Sensitivity:	5dBμV, S/N>60dB at 25 deviation
Sampling Rate:	96kHz 24-Bit
Default Audio Equalizer:	Simulate of various cartridge sound
Max. Deviation Range:	±45KHz
S/N:	>100dB
T.H.D.:	<0.5%@1KHz
Frequency Response:	45Hz-18KHz ±3dB
Operating Range:	80M typical (in open space)
Power Supply:	DC 12~18V / 1A
Output Connector:	XLR balanced & 6.3φ phone jack unbalanced
Dimension (mm):	410(W)×206(D)×43(H)
Weight:	Approximately 2.0kg



UR-222

Wireless Handheld Microphone

- Handheld wireless microphone, simple design style, durable metal material, high contrast OLED display, built-in gain adjustment function, mute switch (optional mechanical switch). Microphone modular design, and various features of the capsule module optional, suitable for various occasions such as speech, singing, etc.

Carrier Frequency Range:	470MHz~936.85MHz
Oscillation:	PLL Synthesized
Harmonic Radiation:	<45dBm
Bandwidth:	134MHz (It depends on the region)
Max. Deviation Range:	±45KHz
Microphone Element:	Dynamic/Condenser (removable)
RF Output Power:	20mW/2mW
Battery:	Aax2
Current Consumption:	110mA (Typical)
Battery Current/ Life:	Approximately 11 hours
Microphone Lengths(mm):	52(Φ)×255(L)
Weight(w/o battery):	Approximately 235g



UR-222

Wireless Bodypack Transmitter

- bodypack-style wireless microphone, simple design, lightweight and practical engineering materials, durable, multi-function OLED display, built-in input selector switch, can be used to facilitate the instrument. The standard mini XLR microphone interface is suitable for a variety of well-known headset and clip microphones on the market. It is suitable for applications such as speech and singing.

Carrier Frequency Range:	470MHz~936.85MHz
Oscillation:	PLL Synthesized
Harmonic Radiation:	<45dBm
Bandwidth:	134MHz (It depends on the region)
Max. Deviation Range:	±45KHz
Input Connector:	4-pin mini-XLR connector
RF Output Power:	20mW/2mW
Battery:	Aax2
Current Consumption:	110mA (Typical)
Battery Current/ Life:	Approximately 11 hours
Microphone Lengths(mm):	84(H)×66(W)×23(D)
Weight(w/o battery):	Approximately 155g

UR-222D

DUAL-CHANNEL ANTENNA DIVERSITY
WIRELESS MICROPHONE SYSTEM



UR-222D Series of condensed the technology essence that Relacart accumulated over a long period. With advanced technology, sophisticated design, stable performance, with beautiful appearance, convenient operation and attractive price, with superior professional quality to win the market competition. This series is suitable for the nightclub of high requirements, multi-functional hall, hotel, conference room and small to medium performance.

Key Features



AFS(Automatic Frequency Selection)

- Press the "AFS" (Auto Frequency Selection) button 3 sec and the receiver will auto-scan and lock on to an open, interference-free frequency.



IR Infrared

- With [IR] infrared automatic frequency matching function, as long as the [SYNC] button is pressed, the transmitter can automatically and accurately lock the working frequency of the receiver.



Anti-Interference

- The stable PLL phase-locked oscillation circuit, combined with the "noise detection" mute control function, can effectively block the noise and radio frequency interference in the working environment.



Flexibility

- The handheld microphone: novel design, OLED display screen, showing battery level, working channel and frequency. The tube is made by durable alloy, effectively protecting the circuit element and battery rack, and with ergonomic grip.
- The new optimized circuit design, good sound quality, transmission distance is longer and more stable
- The capsule of handheld microphone can be removed and replaced, and the condenser or dynamic capsule can be used. It's compatible with SHURE SM-58 capsule. Using 6.3 mm unbalanced output and XLR balanced output synchronization output design, convenient to connect all kinds of audio processing equipment



Super Wide Frequency Range

- Ultra-wide frequency band UHF 522MHz~936 MHz, automatic frequency selection, CPU smart antenna diversity reception: 32 adjustable frequency points per channel, 64 adjustable frequency points in total for two channels, a total of 24 frequency bands can provide 768 adjustable frequency points for users to choose.



Univesal Propery

- 134MHz broadband transmitter, the machines of four different frequency bands can be used interchangeably at will, which is convenient for debugging and management.



Environmental Protection and Energy Conservation

- Precise low-power circuit design makes the battery life twice as long as that of ordinary microphones.

Product Specification



UR-222D

Dual Channel Wireless Receiver

- EIA Standard Rack 1U metal rack receiver chassis, offering new style and simple LCD display;
- Bright LCD display can simultaneously display the working channel or frequency, RF & AF signal status, transmitter battery consumption as well as mute level.
- Antenna output with 8V DC

Main Frame Size:	EIA Standard Rack 1U
Channels:	Dual Channel
Frequency Stability:	±0.005% (-10°C~50°C)
Carrier Frequency Range:	521.25MHz~936.85MHz
Modulation Mode:	FM
Oscillation:	PLL synthesized
Receiving Sensitivity:	5dBμV, S/N>60dB at 25 deviation
Bandwidth:	32MHz
Max. Deviation Range:	±45KHz
S/N:	>105dB
T.H.D.:	<0.7%@1KHz
Frequency Response:	80Hz-18KHz ±3dB
Operating Range:	80M typical (in open space)
Power Supply:	DC 12V / 12W
Dimension (mm):	410(W)×206(D)×43(H)
Weight:	Approximately 1.9kg



UH-222

Wireless Handheld Microphone

- Handheld wireless microphone, simple design style, durable metal material, high contrast OLED display, built-in gain adjustment function, mute switch (optional mechanical switch). Microphone modular design, and various features of the capsule module optional, suitable for various occasions such as speech, singing, etc.

Carrier Frequency Range:	470MHz~936.85MHz
Oscillation:	PLL Synthesized
Harmonic Radiation:	<45dBm
Bandwidth:	134MHz(It depends on the region)
Max. Deviation Range:	±45KHz
Microphone Element:	Dynamic/Condenser(removable)
RF Output Power:	20mW/2mW
Battery:	Aax2
Current Consumption:	110mA(Typical)
Battery Current/ Life:	Approximately 11 hours
Microphone Lengths(mm):	52(Φ)×255(L)
Weight(w/o battery):	Approximately 235g



UT-222

Wireless Bodypack Transmitter

- bodypack-style wireless microphone, simple design, lightweight and practical engineering materials, durable, multi-function OLED display, built-in input selector switch, can be used to facilitate the instrument. The standard mini XLR microphone interface is suitable for a variety of well-known headset and clip microphones on the market. It is suitable for applications such as speech and singing.

Carrier Frequency Range:	470MHz~936.85MHz
Oscillation:	PLL Synthesized
Harmonic Radiation:	<45dBm
Bandwidth:	134MHz(It depends on the region)
Max. Deviation Range:	±45KHz
Input Connector:	4-pin mini-XLR connector
RF Output Power:	20mW/2mW
Battery:	Aax2
Current Consumption:	110mA(Typical)
Battery Current/ Life:	Approximately 11 hours
Microphone Lengths(mm):	84(H)×66(W)×23(D)
Weight(w/o battery):	Approximately 155g

UR-222S

SINGLE-CHANNEL ANTENNA DIVERSITY WIRELESS MICROPHONE SYSTEM



UR-222S Series of condensed the technology essence that Relacart accumulated over a long period. With advanced technology, sophisticated design, stable performance, with beautiful appearance, convenient operation and attractive price, with superior professional quality to win the market competition. This series is suitable for the nightclub of high requirements, multi-functional hall, hotel, conference room and small to medium performance.

Key Features

AFS(Automatic Frequency Selection)

• Press the "AFS"(Auto Frequency Selection) button 3 sec and the receiver will auto-scan and lock on to an open, interference-free frequency.

IR Infrared

• Press [IR] button to upload automatically the receiver frequency to the transmitter.

Anti-Interference

• PLL(Phase Lock Loop frequency control) design ensures transmission reliability, "NoiseLock" squelch effectively blocks stray RF.

Flexibility

• The handheld microphone: novel design, OLED display screen, showing battery level, working channel and frequency. The tube is made by durable alloy, effectively protecting the circuit element and battery rack, and with ergonomic grip.
 • The new optimized circuit design, good sound quality, transmission distance is longer and more stable
 • The capsule of handheld microphone can be removed and replaced, and the condenser or dynamic capsule can be used. It's compatible with SHURE SM-58 capsule. Using 6.3 mm unbalanced output and XLR balanced output synchronization output design, convenient to connect all kinds of audio processing equipment

Super Wide Frequency Range

• UHF 521.25-936.85MHz operating frequency range, with AFS (Auto Frequency selection) function, single-channel diversity reception, frequency-selective greater.

Univesal Propery

• 134MHz transmitter, specially designed for capable of full frequency range transmission.

Environmental Protection and Energy Conservation

• Precise low-power circuit design makes the battery life twice as long as that of ordinary microphones.

Product Specification



UR-222S

Single Channel Wireless Receiver

- 1U Half-Rack metal rack receiver chassis, offering new style and simple LCD display;
- Bright LCD display can simultaneously display the working channel or frequency, RF & AF signal status, transmitter battery consumption as well as mute level.
- Antenna output with 8V DC

Main Frame Size:	1U Half-Rack
Channels:	Single Channel
Frequency Stability:	±0.005% (-10°C-50°C)
Carrier Frequency Range:	521.25MHz~936.85MHz
Modulation Mode:	FM
Oscillation:	PLL synthesized
Receiving Sensitivity:	6dBμV, S/N>60dB at 25 deviation
Bandwidth:	32MHz
Max. Deviation Range:	±45KHz
S/N:	>105dB
T.H.D.:	<0.7%@1KHz
Frequency Response:	80Hz-18KHz ±3dB
Operating Range:	80M typical (in open space)
Power Supply:	DC 12V / 12W
Output Connector:	XLR balanced & 6.3φ phone jack unbalanced
Dimension (mm):	205(W)×206(D)×43(H)
Weight:	Approximately 1.0kg



UH-222

Wireless Handheld Microphone

- Handheld wireless microphone, simple design style, durable metal material, high contrast OLED display, built-in gain adjustment function, mute switch (optional mechanical switch). Microphone modular design, and various features of the capsule module optional, suitable for various occasions such as speech, singing, etc.

Carrier Frequency Range:	470MHz~936.85MHz
Oscillation:	PLL Synthesized
Harmonic Radiation:	<45dBm
Bandwidth:	134MHz(It depends on the region)
Max. Deviation Range:	±45KHz
Microphone Element:	Dynamic/Condenser(removable)
RF Output Power:	20mW/2mW
Battery:	Aax2
Current Consumption:	110mA(Typical)
Battery Current/ Life:	Approximately 11 hours
Microphone Lengths(mm):	52(Φ)×255(L)
Weight(w/o battery):	Approximately 235g



UT-222

Wireless Bodypack Transmitter

- bodypack-style wireless microphone, simple design, lightweight and practical engineering materials, durable, multi-function OLED display, built-in input selector switch, can be used to facilitate the instrument. The standard mini XLR microphone interface is suitable for a variety of well-known headset and clip microphones on the market. It is suitable for applications such as speech and singing.

Carrier Frequency Range:	470MHz~936.85MHz
Oscillation:	PLL Synthesized
Harmonic Radiation:	<45dBm
Bandwidth:	134MHz(It depends on the region)
Max. Deviation Range:	±45KHz
Input Connector:	4-pin mini-XLR connector
RF Output Power:	20mW/2mW
Battery:	Aax2
Current Consumption:	110mA(Typical)
Battery Current/ Life:	Approximately 11 hours
Microphone Lengths(mm):	84(H)×66(W)×23(D)
Weight(w/o battery):	Approximately 155g

UR-111S

SINGLE-CHANNEL ANTENNA DIVERSITY WIRELESS MICROPHONE SYSTEM



UR-111S Series of condensed the technology essence that Relacart accumulated over a long period. With advanced technology, sophisticated design, stable performance, with beautiful appearance, convenient operation and attractive price, with superior professional quality to win the market competition. This series is suitable for the nightclub of high requirements, multi-functional hall, hotel, conference room and small to medium performance.

Product Specification



UR-111S
Single Channel Wireless Receiver

- 1U Half-Rack metal rack receiver chassis, offering new style and simple LCD display;
- Bright LCD display can simultaneously display the working channel or frequency, RF & AF signal status, transmitter battery consumption as well as mute level.

Main Frame Size:	1U Half-Rack
Channels:	Single Channel
Frequency Stability:	±0.005% (0~50°C)
Carrier Frequency Range:	521.25MHz~936.85MHz
Modulation Mode:	FM
Oscillation:	PLL synthesized
Receiving Sensitivity:	5dBµV, S/N>60dB at 25 deviation
Bandwidth:	32MHz
Max. Deviation Range:	±45KHz
S/N:	>105dB
T.H.D.:	<0.7%@1KHz
Frequency Response:	45Hz-18KHz ±3dB
Operating Range:	60M typical (in open space)
Power Supply:	DC 12V / 12W
Output Connector:	XLR balanced & 6.3φ phone jack unbalanced
Dimension (mm):	205(W)×206(D)×43(H)
Weight:	Approximately 1.0kg

Key Features

Extensive Audio Output

- Using 6.3 mm unbalanced output and XLR balanced output synchronization output design, convenient to connect all kinds of audio processing equipment.

Multi-Channel Group Mode

- Four frequency group in total, 40 channels, providing more than 400 adjustable frequency for the users. Battery life is twice as common, up to 15 hours.

AFS(Automatic Frequency Selection)

- Press the "AFS" (Auto Frequency Selection) button 3 sec and the receiver will auto-scan and lock on to an open, interference-free frequency.

IR Infrared

- Press [IR] button to upload automatically the receiver frequency to the transmitter.

Super Wide Frequency Range

- Ultra-wide carrier frequency UHF 521.5MHz~936MHz, one-to-two antenna diversity reception, CPU intelligent selection, stable reception and long distance, providing users with a good application experience.

Noise lock

- Adopt noise locking and field strength locking double squelch locking circuit design, effectively prevent the radio frequency interference of other microphones, and improve the signal-to-noise ratio.

PLL Phase Lock Loop Frequency Control

- PLL(Phase Lock Loop frequency control) design ensures transmission reliability, "NoiseLock" squelch effectively blocks stray RF.

Reliable and Flexible Performance

- Designed for use on professional tours, multi-functional halls, meeting room, concert halls and houses of worship. Stable functions, reliable and flexible performance, easy to install.



UH-222
Wireless Handheld Microphone

- Handheld wireless microphone, simple design style, durable metal material, high contrast OLED display, built-in gain adjustment function, mute switch (optional mechanical switch). Microphone modular design, and various features of the capsule module optional, suitable for various occasions such as speech, singing, etc.

Carrier Frequency Range:	470MHz~936.85MHz
Oscillation:	PLL Synthesized
Harmonic Radiation:	<45dBm
Bandwidth:	134MHz(It depends on the region)
Max. Deviation Range:	±45KHz
Microphone Element:	Dynamic/Condenser(removable)
RF Output Power:	20mW/2mW
Battery:	Aax2
Current Consumption:	110mA(Typical)
Battery Current/ Life:	Approximately 11 hours
Microphone Lengths(mm):	52(Φ)×255(L)
Weight(w/o battery):	Approximately 235g



ET-50
Wireless Bodypack Transmitter

- Bodypack-style wireless microphone, simple design, lightweight and practical engineering materials, durable, multi-function LCD display, built-in input selector switch, can be used to facilitate the instrument. The standard mini XLR microphone interface is suitable for a variety of well-known headset and clip microphones on the market. It is suitable for applications such as speech and singing.

Switching bandwidth:	521.25MHz-936.85MHz
Oscillation:	PLL synthesized
RF Output Power:	5mW/30mW
Carrier deviation:	0.5KHz
Harmonic radiation:	≤45dB
Modulation:	FM
Nominal/ Peak deviation:	±45KHz
Max. Input Level:	Maximum input - 11dBv
Frequency Set-Up:	IR Sync
Power Requirements:	2× AA 1.5V batteries
Battery Life:	>8 hours
Dimensions(mm):	95(H)×65(W)×25(D)
Net Weight :	About 80g(without battery)

BG-24 | 2.4G SINGLE-CHANNEL TRI-DIVERSITY WIRELESS MICROPHONE SYSTEM



BG-24 is an industry-first wireless microphone system that integrates three diversity techniques: frequency diversity, time diversity, and antenna diversity. It features a sleek and durable design crafted from a strong aluminum alloy. Its bright OLED display provides clear visibility of the device's status. Optional dual-bay chargers for handheld microphones enhance charging management convenience. Operating on the 2.4 GHz frequency band, this ensures unrestricted use in any country. With Relacart's proprietary digital audio algorithms, BG-24 offers ultra-low latency transmission, making it ideal for small to medium-sized performances, business meetings, conference rooms, schools, home entertainment, and more.

Key Features

Independently developed low-latency compression algorithm

Relacart independently develops digital audio algorithm with compression and decompression latency less than 3 ms, significantly ahead of other 2.4G digital wireless microphones on the market and provides an excellent solution for the overall digital audio system. Additionally, the frequency occupied bandwidth is less than 1MHz, greatly reducing the external and intermodulation interference.

2.4G unlimited frequency band

Adopting the globally unrestricted 2.4G transmission frequency band, it can be used freely in any region without frequency restrictions. The effective transmission distance is up to 50 meters in open environments.

AES-256 Encryption

Equipped with AES-256 high-level encryption suitable for any scenario requiring secure transmission, such as confidential meetings. This ensures privacy protection while simultaneously eliminating RF interference by allowing only encrypted signals to reach the receiver.

Stable wireless transmission

- Relacart's innovative wireless audio system circuit provides it with a stable wireless transmission.
- It has antenna diversity reception mode to ensure safe wireless signal reception.
- Frequency diversity provides backup frequencies and automatic hopping functions, allowing it to flexibly avoid complex wireless frequency interference.
- Time diversity technology works by transmitting the same signal at different times. The receiver can receive multiple independently fading copies and combine these copies (such as maximum ratio combining, equal gain combining, etc.), which can significantly reduce the risk of signal loss due to poor channel conditions at any specific moment.

High fidelity sound reproduction

The BG-24 digital wireless microphone system provides users with an extremely flat frequency response curve. It has a frequency response range of 20-20kHz and a distortion of <0.1%, giving the most fidelity sound for speech reproduction.

Optional dual-bay chargers

Optional contact-type dual bay changer, simply place the microphone into it for charging. Utilizing rechargeable NiMH batteries, it offers a longer lifespan compared to alkaline batteries, ensuring enhanced safety, durability, and environmental friendliness. This convenient charging method is suitable for various scenarios requiring frequent charging.

Product Specification



BG-24R
Single Channel Wireless Receiver

- 1U Half-Rack receiver chassis. Using a high-brightness LCD display, even in dim usage scenarios, it can still clearly display the device's frequency band, power, grouping, lock/unlock and other working status.

Main Frame Size:	1U Half-Rack
Receiving Channel:	Single Channel
Reception Method:	Antenna diversity/frequency diversity/Time Diversity
Audio Format:	Relacart proprietary digital audio format
Wireless Carrier Frequency:	2.4-2.48GHz
Compatible Channels:	≥ 14
Display Channel:	LCD
Effective Distance:	50 meters (open space)
Sampling:	24bit/48kHz
Encryption:	AES-256
Delay:	≤2.9ms, ≤ 3.8ms (encryption enabled)
Dynamic Range:	≥ 110dB (A-weighted)
Frequency Response:	20Hz-20kHz(± 1dB)
Comprehensive T.H.D.:	<0.1% @ 1KHz
System Gain Adjustment:	(-18~18 dB)
Audio Output Interface:	XLR balanced output, 1/4 "unbalanced output
Power Supply:	DC/12V
Current Load:	≤150mA
Dimensions(mm):	200 (L) × 200 (D) × 44 (H)



BG-24H
Wireless Handheld Microphone

- The casing is made of sturdy and durable aluminum alloy, and is equipped with bright OLED to clearly display working status such as frequency band, power, group, lock/unlock, etc. Powered by two pc of AA battery or NiMH battery. It can be put in the dual-bay charger for charging when adopt NiMH battery. It is suitable for various occasions that require frequent charging.

Audio Format:	Relacart proprietary digital audio format
Wireless Carrier Frequency:	2.4-2.48GHz
Transmission Method:	Frequency diversity
Modulation Method:	GFSK
Transmission Rate:	1Mbps
Sampling:	24bit/48kHz
Compatible Channels:	≥ 14
Display Channel:	OLED
Dynamic Range:	≥ 110dB (A-weighted)
Frequency Response:	20Hz-20kHz (± 1dB)
Sensitivity:	≤ -45dB
RF Power:	≥ 50mW
Power Supply:	Alkaline battery (AA) × 2
Current Load:	145mA (typical value)
Battery Life:	≥ 8 hours
Dimensions(mm):	55 (Φ) × 269 (L)



BG-24T
Wireless Bodypack Transmitter

- The casing is made of sturdy and durable aluminum alloy, and is equipped with bright OLED to clearly display working status such as frequency band, power, group, lock/unlock, etc. Powered by two pc of AA battery or NiMH battery. It can be put in the dual-bay charger for charging when adopt NiMH battery. It is suitable for various occasions that require frequent charging.

Audio Format:	Relacart proprietary digital audio format
Wireless Carrier Frequency:	2.4-2.48GHz
Transmission Method:	Frequency diversity
Modulation Method:	GFSK
Transmission Rate:	1Mbps
Sampling:	24bit/48kHz
Compatible Channels:	≥ 14
Display Channel:	OLED
Dynamic Range:	≥ 110dB (A-weighted)
Frequency Response:	20Hz-20kHz (± 1dB)
Sensitivity:	≤ -45dB
RF Power:	≥ 50mW
Power Supply:	Alkaline battery (AA) × 2
Current Load:	145mA (typical value)
Battery Life:	≥ 8 hours
Dimensions(mm):	65 (L) × 21.3 (W) × 75.5 (H)



RC-2
Dual-bay Charger

- Dual Bay Charger is suitable for Relacart rechargeable handheld transmitters and bodypack transmitters. Just put the transmitters into it for charging. It can display the current device power and has a charging completion indicator light.

Compatible transmitters:	Up to 2 × UH-280, UT-280, BG-24H, or BG-24T
Compatible transmitter charging parameters:	
Charging current:	Fast charge 1.1 A; slow charge 500 mA
Charging time:	3 hours = 50% charged; 6 hours = 100% charged (battery capacity: 2600 mAh)
External power supply:	DC 12V / 1A (maximum of 4 units can be connected in daisy chain)
External power supply required when connected in daisy chain:	12V / 2A (2 units) 12V / 3A (3 units) 12V / 4A (4 units)
Compatible SONY camera battery charging parameters:	
Charging current:	600 mA
Charging time:	1.5 hours = 50% charged; 3 hours = 100% charged (battery capacity: 1500 mAh)
Operating temperature range:	-18°C (0°F) to 50°C (122°F)
Storage temperature range:	-29°C (-20°F) to 74°C (165°F)
Dimensions (mm):	185 (W) × 88 (D) × 86 (H)
Weight:	Approx. 155 g

TAC4 | IEM TRANSMITTER ANTENNA COMBINER



The Relacart TAC4 antenna combiner can consolidate signals from up to four in-ear wireless monitor stereo transmitters onto a single shared antenna, effectively minimizing intermodulation distortion caused by interference between adjacent transmitters. This is crucial for multi-channel systems. It can be used with any brand of IEM set to transmit power of 100mW or lower. Additionally, it can provide DC power to up to four IEM transmitters, eliminating the need for wall-mounted power adapters.

Product Specification



TAC4
IEM Transmitter Antenna Combiner

Frequency Range:	470-940 MHz
Input/output Impedance:	50Ω
RF Gain:	0dB (±2dB)
Connector Type:	BNC
RF Signal Input:	4 channels
RF input normal operating range:	+20dBm max.
RF input signal LED indicator threshold:	>7dBm
Input Loss:	<3dB
Output Voltage:	4 channels 12V (DC) 1A maximum
Power Supply:	AC 100-240V, 50-60Hz 60W Max.
Dimensions (mm):	480(W)×350(D)×43(H)

System Connection Diagram

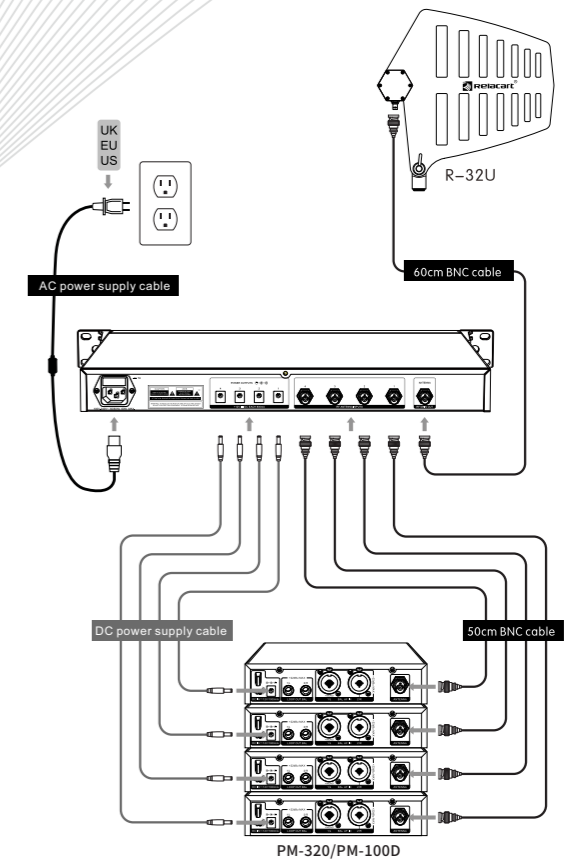

Key Features

Improve Wireless Performance

- It can reduce the intermodulation distortion and dropouts due to multipath interference

Super Wide Frequency Range

- Wideband UHF operation (470-940 MHz)

Power Supply for Transmitters

- Four DC output jacks supplying power to the connected IEM transmitters

LED Indicator of Signal Presence

- Front-panel LED signal indicators for each input (Lights green when there is signal input; off when there is no signal)

Wide Compatibility

- Compatible with the IEM transmitters of all brands

PM-320

WIRELESS DIVERSITY IN-EAR MONITOR SYSTEM



PM-320 is a wireless monitoring system for stage performances and audio broadcasting, and a wireless listening system for large simultaneous interpretation conferences. High-fidelity sound, advanced electronic processing technology instead of the traditional complicated and heavy monitoring equipment, eliminate the howling from the monitoring equipment, and make the performance reliable and perfect.

Key Features

PLL PLL Phase Locked Oscillation Circuit

- Stable PLL phase-locked oscillator circuit, combined with the "noise detection" mute control function, can effectively block the noise and radio frequency interference in the working environment.

Super Wide Frequency Range

- The bandwidth is 32MHz, with 1280 adjustable frequencies. Channel groups 1-10 are factory preset with up to 180 fixed frequencies. Channel groups U1-U5 can freely set and save frequencies.

UHF UHF Audio Transmission Technology

- The receiver adopts the UHF frequency band, and the CPU controls the diversity reception to reduce dead spots and ensure stable reception.

Real-time Monitoring

- Has a headphone monitor output.

long distance audio transmission

- It has a long transmission distance and is suitable for various occasions.

Product Specification



PM-320R
Stereo Wireless Bodypack Receiver

- The housing of PM-320R receiver is made of light-weight and tough alloy materials.
- Exquisite and simple OLED multifunctional display.
- The receiver uses the UHF frequency band, and the CPU controls diversity reception to reduce dead spots and ensure stable reception.
- With headphone monitoring output.
- With long transmission distance, it is suitable for various occasions.

Receiving Method:	Antenna diversity reception
Channel:	Single channel
Frequency Stability:	± 0.005% (0 ~ 50°C)
Carrier Frequency Range:	521.25MHz ~ 936.85 MHz
Modulation Mode:	FM (wideband stereo)
Working Range:	100 meters (in open space)
Oscillation:	PLL phase locked frequency synthesis
Sensitivity:	6dBuV, S / N > 60dB at 25KHz deviation
Bandwidth:	32MHz (1280 frequencies, 25 KHz step in tune)
Max. Deviation Range:	± 48KHz
Comprehensive S / N :	> 100dB
Comprehensive T.H.D.:	<0.9%@1KHz
Comprehensive Frequency Response:	50Hz-15KHz ± 3dB
Stereo Separation:	≥45dB, at 1KHz
Output Connector:	φ3.5mm stereo headphone connector
Output Power:	2×150mW at 1KHz (T.H.D. : 3%)
Battery:	AA×2
Current Consumption:	185mA (typical)
Battery Life:	About 7 hours
Dimension (mm):	90(H)×65(W)×23(D)
Weight:	Approximately 190g



PM-320T
Stereo Transmitter

- Metal 1 U Half-Rack case.
- The bandwidth is 32MHz and there are 1280 adjustable frequencies. 1-10 Channel groups, more than 180 fixed frequencies for choose. Channel groups U1-U5 can set and save frequencies freely.
- Stereo and mono selection
- Treble boost function, limit control function
- The stable PLL phase-locked oscillation circuit, combined with the "noise lock" squelch can effectively block stray RF.

Main Frame Size:	1U Half-Rack
Frequency Stability:	± 0.005% (-10~ 50°C)
Carrier Frequency Range:	521.25MHz ~ 936.85 MHz
Modulation Mode:	FM (wideband stereo)
Output Power:	10mW
Oscillation:	PLL phase locked frequency synthesis
Bandwidth:	32MHz
Harmonic Radiation:	60dB below the main wave
Max. Deviation Range:	± 50KHz
Comprehensive S / N :	>100dB
Comprehensive T.H.D.:	<0.9%@1KHz
Comprehensive Frequency Response:	50Hz-15KHz ± 3dB
Audio Input:	Line level × 2, 6.3mm Stereo/XLR Combo Jack
Audio Loop Output:	6.3mm Stereo jack ×2
Dimension(mm):	206 (W)×206(D)×43(H)
Weight:	1.0kg



4 Port Go is a portable audio adapter designed for live production. It can easily connect four HCR-30D true diversity camera wireless receiver systems, so as to provide multiple channels of audio transmission and management to recorders, cameras, mixers and other devices more conveniently without complicated entanglements. Provide balanced mini XLR audio output. The appearance is made of solid alloy, and the compact design can be put into the camera bag to carry with you, which is suitable for professional film and television production and outdoor shooting.

Product Specification



Frequency Range:	470 MHz – 960 MHz
Splitter Amplifier Gain:	0 dB, ±3 dB (typical)
Antenna Power Supply (BNCA/B):	The display screen shows the current operating voltage of the system.
Maximum current:	150 mA (center pin positive)
Input/Output Impedance:	50 Ω
Audio Output Connectors:	8 × 3-pin mini XLR balanced audio outputs
DC Power Input:	DC IN: 8-12 V, 2 A
DC Power Output:	DC EXT: 10 V, 1 A
Battery:	Li-ion battery
Nominal Voltage:	7.4 V
Dimensions (mm):	260 (L) × 126.5 (W) × 88 (H)
Weight:	Approx. 1.5 kg

4 Port Go

Portable Audio Adapter



Key Features

Portable design

- The appearance is made of lightweight and durable alloy, very compact. It can be put into the camera bag and carried for professional audio recording anytime and anywhere.

Multiple power supplies

- Built-in multiple power supply methods to power four receivers, and usually prioritize power supply through two external DC interfaces. It can also be powered by an external battery. When one of the power supplies is powered off, it will automatically switch to avoid recording interruptions caused by unexpected situations.

Antenna distribution

- Stable PLL phase-locked oscillator circuit, combined with the "noise detection" mute control function, can effectively block the noise and radio frequency interference in the working environment.



HCR-30D
UHF True Diversity ENG
Wireless Receiver

Reception Mode:	True diversity reception
Carrier Frequency Band:	521.25MHz~936.85MHz
Frequency Stability:	±0.005%
Modulation Method:	FM
Effective Working Distance:	generally 100 meters (open space)
Oscillation Mode:	PLL phase locked frequency synthesis
Sensitivity:	S/N >76 dB at 6 dBuV input at offset equal to 25 KHz
Bandwidth:	32MHz
Max.Deviation Range:	±75KHz
Sampling Rate:	ADC 24-bit, DAC 24-bit, sampling rate 96 KHz
Comprehensive S/N ratio:	>105dB
Comprehensive T.H.D:	<0.7%@1KHz
Comprehensive Frequency Response:	80Hz-18KHz ±3dB
Output Interface:	Panasonic/Sony/mini XLR
Power Supply:	DC7V/280mA-18V/220mA
Current Consumption:	180mA (typ.)
Working Temperature:	-25°C ~ 60°C
Dimensions(mm):	110(H)×73(W)×28(D)
Weight:	About 210g

HCR-300

UHF TRUE DIVERSITY ENG
WIRELESS RECEIVER



HCR-300 is a wireless microphone system specially designed for professional cameras. At the same time, the intelligent channel diversity receiver can be divided into single channel true diversity and dual channels antenna diversity switching. Mainly used in professional video cameras, which is also attached with camera adapters for Sony and Panasonic can work with wireless handheld mics or wireless bodypack transmitters, the camera can avoid the ties of the microphone signal line during recording, make the distance between the audio and video more closely combined, achieve the recording effect of the original sound reproduction, and ensure the camera's sound quality. Motorized operation, more flexible, convenient and safe to use.

Product Specification



HCR-300

UHF True Diversity ENG
Wireless Receiver

Reception Mode:	True diversity reception
Carrier Frequency Band:	521.25MHz~936.85MHz
Frequency Stability:	±0.005%
Modulation Method:	FM
Effective Working Distance:	generally 100 meters (open space)
Oscillation Mode:	PLL phase locked frequency synthesis
Sensitivity:	S/N >76 dB at 6 dBuV input at offset equal to 25 KHz
Bandwidth:	32MHz
Max.Deviation Range:	±75KHz
Sampling Rate:	ADC 24-bit, DAC 24-bit, sampling rate 96 KHz
Comprehensive S/N ratio:	>105dB
Comprehensive T.H.D.:	<0.7%@1KHz
Comprehensive Frequency Response:	80Hz-18KHz ±3dB
Output Interface:	Panasonic/Sony/mini XLR
Power Supply:	DC7V/280mA-18V/220mA
Current Consumption:	180mA (typ.)
Working Temperature:	-25°C ~ 60°C
Dimensions(mm):	110(H)×73(W)×28(D)
Weight:	Approximately 210g

Key Features

Brand New Design

- With sturdy and waterproof aluminum alloy shell, it can meet professional quality requirements. The new technology OLED display screen can display the working status of transmitter battery, radio frequency and audio at the same time. wireless connection and providing high-fidelity audio output
- Adopt SMA flexible antenna and antenna connector with adjustable angle of 1/4 wavelength.
- With "Panasonic" and "SONY" two kinds of output modules that are easy to remove and replace the fixed bracket, it is easy to install and use on different cameras.
- Camera adapters for Sony® and Panasonic® (Unislot)
- Equipped with ultra-quiet electronic touch switch, which can avoid the mechanical sound amplification of the switch.

AFS (Automatic Frequency Search)

- It has the function of [AFS] to automatically search for the cleanest and freest frequency in the actual environment.

IR(Infrared Automatic Frequency Adjustment)

- With [IR] infrared automatic frequency matching function, as long as the [SYNC] button is pressed, the transmitter can automatically and accurately lock the working frequency of the receiver.

True Diversity Reception

- Ultra-wideband UHF 521.25-936.85MHz, true diversity reception.

DSP DSP Audio Extension Algorithm

- Adopt Relacart's own DSP audio expansion algorithm to minimize the noise brought by the wireless transmission process and restore the best sound. The audio output of the receiver can be set to output in multiple modes (Both Mix, Mix 1, Mix 2, Audio Split). The handheld microphone has a simple design, is dexterous and lightweight, showing a humanized soft grip.

PLL PLL Phase Locked Oscillation Circuit

- Stable PLL phase-locked oscillator circuit, combined with the "noise detection" mute control function, can effectively block the noise and radio frequency interference in the working environment.

High Precision Circuit

- The hardware circuit of the whole system is controlled by a microcomputer, and the advanced computer technology is used to Calculate the frequencies that do not interfere with each other, so that the performance of the whole system is more stable. And it is not easy to appear frequency offset, frequency interruption and other phenomena.



UH-2

Wireless Handheld
Microphone

- Handheld wireless microphone, simple design style, durable metal material, high contrast OLED display, built-in gain adjustment function, humanized mechanical switch, microphone module design, and a variety of characteristics of the sound head module can be matched, suitable for speech, singing and other occasions.

Carrier Frequency Range :	470MHz-960MHz
Harmonic Radiation :	<45dBm
Bandwidth :	Single-band 134MHz
Modulation Mode :	FM
Audio Compression :	Relacart classic audio compression circuit
Capsule :	Dynamic or Condenser, Cardioid
RF Power Output :	10mW/30mW
Battery :	AA x2
Current Consumption :	130mA(typical)
Battery Life :	Approximately 8 hours
Dimensions(mm):	52(Φ)×255(L)
Weight (without battery) :	Approximately 235g



UT-2

Wireless Bodypack
Transmitter

- Contracted design style, solid and dural metal material, high contrast OLED display. Built-in gain adjustment function.
- Standard Mini XLR microphone interface, suitable for the headset mic and clip mic of a variety of well-known brand in the market. Suitable for application in speech, singing and other occasions

Carrier Frequency Range :	470MHz-960MHz
Harmonic Radiation :	<45dBm
Bandwidth :	Single-band 134MHz
Modulation Mode :	FM
Audio Compression :	Relacart classic audio compression circuit
Input Connector :	4-pin mini-XLR connector,
RF Power Output :	Input gain 3 levels adjustable 10mW / 30mW
Battery :	AA x2
Current Consumption :	130mA(typical)
Battery Life :	Approximately 8 hours
Dimensions(mm):	84(H)×66(W)×23(D)
Weight (without battery) :	Approximately 155g

R-14D | WIDEBAND 4-CHANNEL ANTENNA DISTRIBUTION SYSTEM



R-14D is a dual quadripartition antenna distribution system with super wide frequency band, strong power output as well as ultra low distortion. Advanced technology, reliable performance, delicate appearance, compatible to UHF diversity wireless system.

Product Specification



R-14D
Antenna Distribution System

Frequency Range:	470MHz ~ 950 MHz
Gain of Output:	0dB ±1dB
Input Impedance:	50Ω
Output Impedance:	50Ω
Power Supply of Antenna Input:	+8+V DC
Power Supply of Receiver:	Each antenna input port supplies bias +12V DC, 150mA max.
Current Drain:	800mA
Power Supply:	100-240V, AC 50/60 Hz
Dimensions (mm):	410(W)×206(D)×43(H)
Weight:	2.5kg

System Connection Diagram

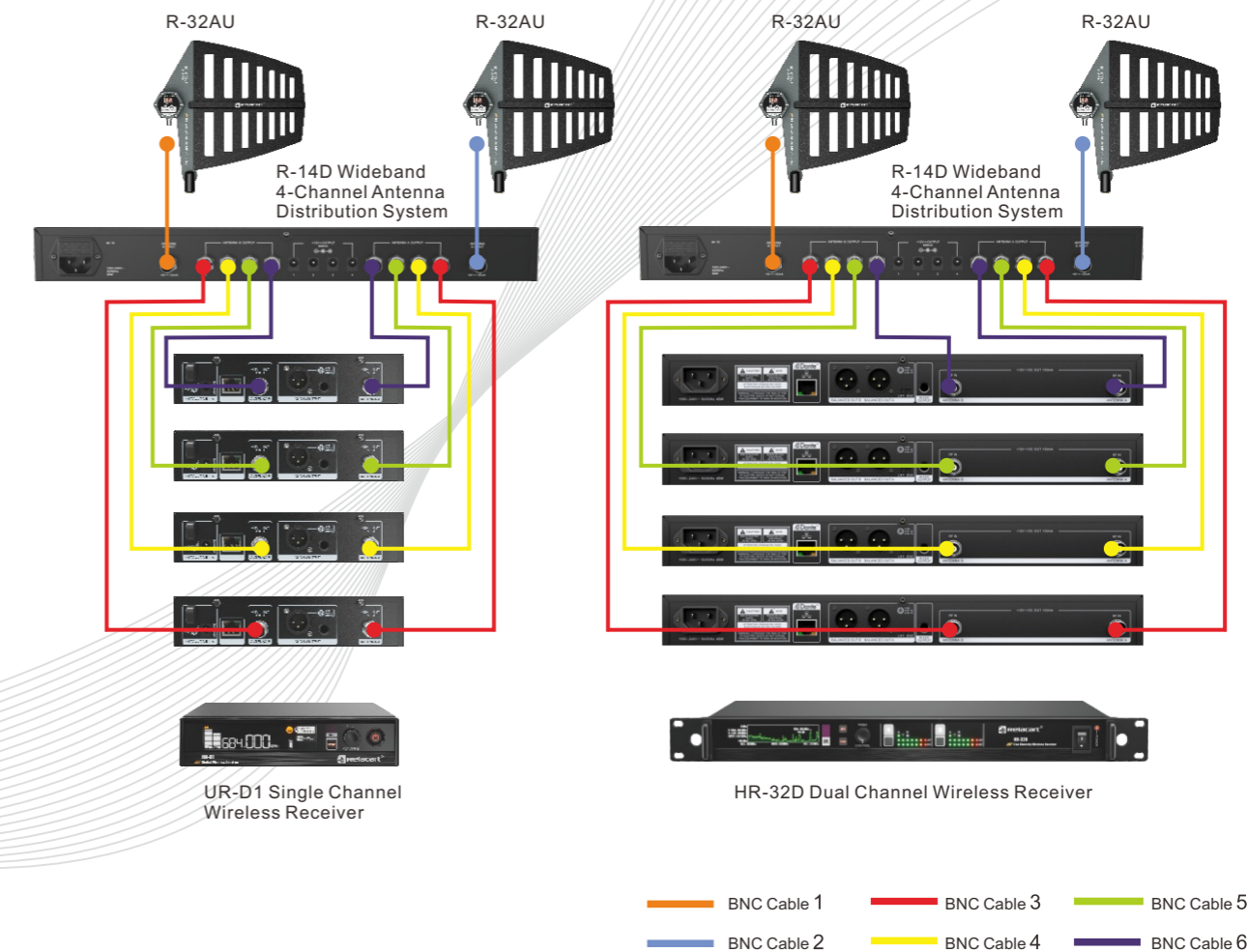

Key Features

Brand New Design

- Support one pair antenna, two to four pieces of Relacart wireless system or other brand wireless system. Simplify the antenna setup and increase system working efficiency.

Stable signal reception

- Antenna input jack compatible with R-32AU directional antenna, enabling large area, multiple direction and far distance wireless transmission, make sure the signal reception is stable.

High Precision Circuit

- Precise circuit design, ultra low noise, low inter modulation distortion, can eliminate the interference from mixed frequency when multiple frequencies are working simultaneously.

WIDE-BAND DIRECTIONAL ANTENNA

Product Specification



R-32AU

Wide-band Directional Antenna

- Light weight appearance, convenient for carrying and set up
- With high direction gain, enhance the receiving signal
- Built-in Antenna Booster.

Antenna Frequency Range:	480MHz~950 MHz
Amplifier Frequency Range:	480MHz~950 MHz
Antenna Directionality:	Cardioid
Antenna Polarization Mode:	line
Antenna Gain:	≥6.5dB
Antenna Standing Wave Ratio:	<2
Amplifier Gain:	0 to 15dB
Amplifier Low Noise:	<0.45dB
Amplifier OIP3:	>38dBm
External Power Supply:	6-12VDC
Current:	5mA
Connector Port:	BNC female
Dimensions (mm):	332(L)×304(W)×3(H)
Weight:	About 715g



R-32U

Directional Antenna

- R-32U has the characteristics of reliable performance durable, which can provide the best receiving effect in the required coverage. The gain setting is used to enhance the signal reception.
- The R-32AU/R-32U can be fixed to the microphone stand or suspended from the ceiling, or it can be fixed to the wall using the integrated rotatable stand.

Antenna Frequency Range:	480MHz~950 MHz
Amplifier Frequency Range:	480MHz~950 MHz
Antenna Directionality:	Cardioid
Antenna Polarization Mode:	line
Antenna gain:	≥6.5dB
Antenna Standing Wave Ratio:	<2
Connector Port:	BNC female
Dimensions (mm):	332(L)×304(W)×3(H)
Weight:	About 715g



R-20U

UHF Wide-band Directional Antenna

- The R-20U directional antenna provides enhanced signal pickup for UHF wireless microphone systems operating in the 470-900MHz frequency range, and is compatible with new foreign telecommunications regulations. Lightweight, structurally durable, UV-degradable ABS cover sheets that provide long life and consistent performance under harsh operating conditions.

Frequency Range:	470MHz~900 MHz
Polar Pattern:	≥25dB
Gain:	7dBi(Typical)
Impedance:	50Ω
Horizontal Flap Width:	80°
Vertical Flap Width:	60°
Max. Power:	50W
Polarization:	Vertical
VSWR:	≤ 2.0
Connector:	BNC
Dimensions (mm):	210(H)×180(W)× 44(D)
Weight:	300g



R-43W

Bar Antenna

- The R-43W is a passive wideband UHF omnidirectional antenna. It is designed to withstand harsh weather conditions, making it suitable for temporary outdoor use. However, it should not be exposed to humid environments for extended periods. The R-43W is compatible with the WDC-903 wireless conference system data communication converter, providing high-gain, 360° omnidirectional signal reception/transmission for stable signal performance with the data communication converter.

Frequency Range:	400MHz~950MHz, 2000MHz~2500MHz
Gain:	9dB
Standing Wave Ratio:	9dB
Input Impedance:	50Ω
Connector Type:	N-type male
Dimensions (mm):	Φ36.5×376
Net Weight:	About 220g

ACCESSORIES

Product Specification



R-12S

Antenna Divider

- R-12S can separate 1 RF signal to 2 RF signals output or combine 2 RF signals to 1 RF signal output. Also it is a RF signal amplifier can transfer the offset voltage to front, is a ideal antenna system accessory.

Frequency Range:	400 MHz ~1000MHz
Attenuation:	-3.5dB, ±1dB
Insulate:	>-20dB
Impedance:	50 ohm
Voltage/Current:	50V DC/1.50A
Connector:	BNC
Size(mm):	65(W)×50(L)×20(H)
Weightabout:	35g



R-20A

Antenna Booster

- R-20A provides increased gain for receiving antennas, maintains an effective and reliable signals and reduces chance for signal dropouts under difficult Rf conditions.
- Compact and lightweight, R-20A is integrated into a small package and can be concatenated in the middle of the connecting cable

Frequency Range:	450~950MHz
Gain:	5dB 15dB
Connector:	BNC female
VSWR:	Input/output≤ 3:1
Power Supply:	DC 8V, 80VmA
Working Temperature:	-50°C to +60°C
Dimensions(mm):	87(W)×65(D)×20(H)
Weight:	85g
Outer Casing:	Black anodized aluminum
Connecting Cable Standard:	50Ω low-loss coaxial cable.



R-20P

Power Supplier for Antenna

- R-20P is a device that supplies power to antennas or antenna amplifiers, providing DC8V, 80mA output, allowing external antenna systems to work independently. The aluminum housing is designed with a rugged, lightweight construction and excellent heat dissipation, making the internal circuitry durable and continuously providing the output voltage, which is a best choice for the antenna receiving system.

Connect:	BNC
Power Requirement:	Power Adapter with 12V/1A
Power Supply:	DC 8V, 300mA
Working Temperature:	-25°C~50°C
Dimension:	87(W)×65(D)×20(H)
Weight:	About 90g
Material:	Black electroplate aluminum

Antenna Mounting Brackets



R-M11
Multi-purpose mounting bracket



R-M13
Wall mounting bracket



R-M17
Wall mounting bracket

HEADWORN MICROPHONES

Product Specification



HM-500(S/B)
Unidirectional

Frequency Response:

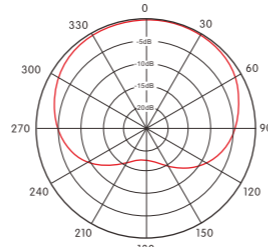
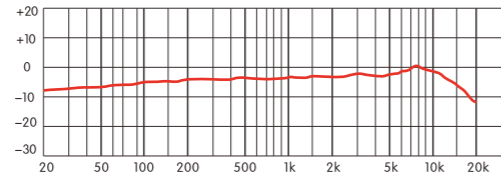

Polar Pattern

Element: Back Electret Condenser
 Polar Pattern : Unidirectional
 Sensitivity : -47dB ±2dB
 Output Impedance : ≤2.2KΩ
 S/N Ration : ≥58dB
 Dimensions of capsule : Φ6.0×5.0mm
 Frequency Response : 45Hz-18KHz
 Power Supply : 2-10V DC
 Cable : 1.2m
 Connector: Mini XLR-4P



HM-P06
Unidirectional

Frequency Response:

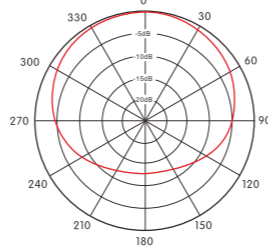
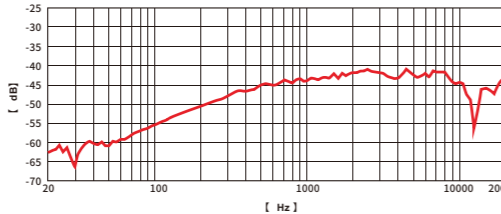

Polar Pattern

Element: Back Electret Condenser
 Frequency range: 50Hz-15KHz
 Directivity: Unidirectional
 Sensitivity: -42dB ± 1.5dB at 1KHz (0dB=1V/Pa)
 Output Impedance: 2.2KΩ ± 5% at 1KHz
 Total harmonic distortion: THD 0.8%/1KHz
 Max. SPL: 94dB/SPL
 S/N Ration: >65dB
 Dimensions of capsule: Φ6.0×3.0mm
 Connector: 3.5mm plug
 Weight: About 23.9g
 Color: Skin



HM-P07
Unidirectional

Frequency Response:

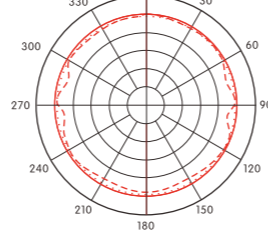
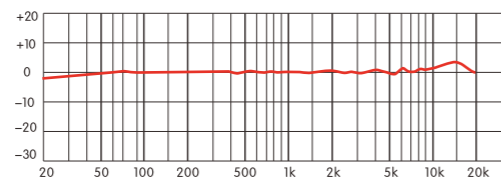

Polar Pattern

Element: Back Electret Condenser
 Polar Pattern : Omnidirectional
 Sensitivity : -40.5dB ±2dB
 Output Impedance : ≤2.2KΩ
 S/N Ration : ≥59dB
 Dimensions of capsule : Φ4.0×1.5mm
 Frequency Response : 20Hz-18KHz
 Power Supply : 2-10V DC
 Cable : 1.2m
 Connector: Mini XLR-4P



HM-600(S/B)
Omnidirectional

LAVALIER MICROPHONES

Product Specification



LM-C480
Unidirectional

Frequency Response:

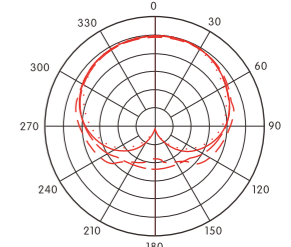
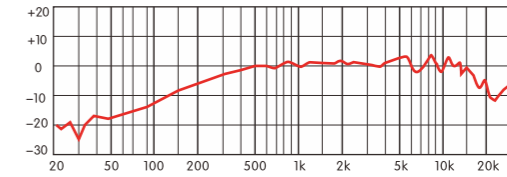

Polar Pattern

Element: Back Electret Condenser
 Polar Pattern : Unidirectional
 Sensitivity: -45dB
 Output impedance: ≤1.8KΩ
 S/N Ration : ≥59dB
 Dimensions of capsule : Φ4.0×1.5mm
 Frequency Response: 60-12000 Hz
 Power Supply: 2-10V DC
 Cable: 1.2m
 Connector: Mini XLR-4P



LM-C550
Omnidirectional

Frequency Response:

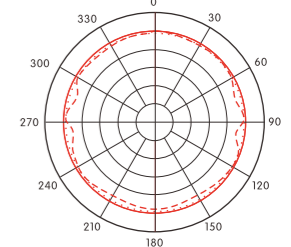
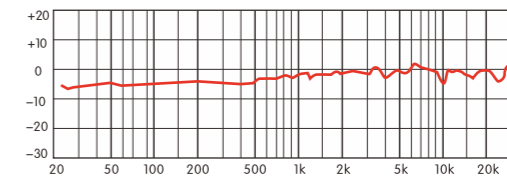

Polar Pattern

Element: Back Electret Condenser
 Polar Pattern: Omnidirectional
 Sensitivity: -41dB
 Output impedance: ≤1.8KΩ
 S/N Ration : ≥59dB
 Dimensions of capsule : Φ4.0×1.5mm
 Frequency Response: 60-12000 Hz
 Power Supply: 2-10V DC
 Cable: 1.2m
 Connector: Mini XLR-4P

MINI HEADPHONE PLUG UNIDIRECTIONAL MICROPHONE



LM-P06
Unidirectional

Frequency Response:

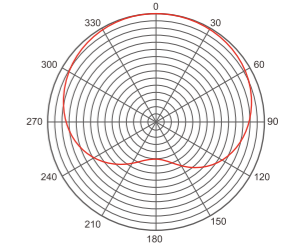
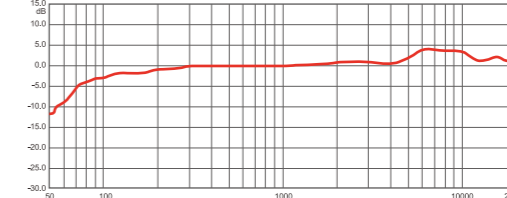

Polar Pattern

Polar Pattern : Unidirectional
 Sensitivity: -32dB±3dB(0dB=1V/Pa)
 Output Impedance: 2.2KΩ
 Maximum SPL: 120.4dB
 SN: 64dB
 Frequency Response: 50Hz-20KHz
 Microphone Size: Φ8.6×33.7mm
 Windshield Size: Φ14mm×15mm
 Output Connector: 3.5mm
 Weight: 5.5g

WIRELESS CAPSULES

Product Specification

Simple and fast, let you have different sound quality

In order to meet the needs of our customers for performance products, each series of performance wireless microphones can have multiple replaceable microphone modules. Each module has different professional timbres and can be matched with different speakers to present sound effects. The microphone module can be replaced quickly, which is convenient for customers to replace microphones with all kinds of sound quality, and makes the maintenance of products easier and faster.

Frequency Response

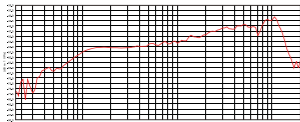

M-D22
Dynamic Microphone Module

Polar Pattern

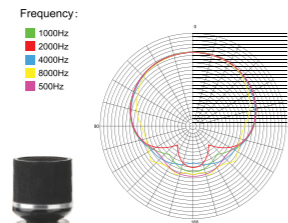

Connectivity:	Relacart UR series wireless handheld microphones Shure® wireless handheld microphones
Type:	Dynamic
Directivity:	Super cardioid
Frequency:	120-16000Hz
Response:	
Flexibility:	-53dB re 1V/Pa
Max SPL:	145dB@ 1%
Dimension(mm):	Φ53×79
Weight:	85g

Frequency Response

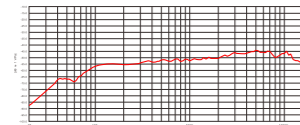

M-D23
Dynamic Microphone Module

Polar Pattern

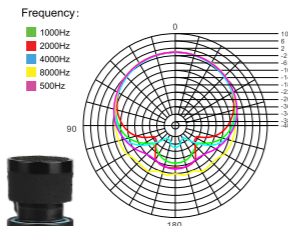

Connectivity:	Relacart HR,UR series wireless handheld microphones Shure® wireless handheld microphones
Type:	Dynamic
Directivity:	Supercardioid
Frequency:	
Response:	70-16000Hz
Flexibility:	-55dB @ 1V/Pa
Max SPL:	145dB@1%
Dimension(mm):	Φ53×79
Weight:	85g

Frequency Response

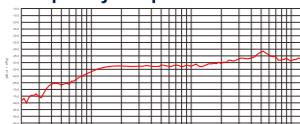

M-D28
Dynamic Microphone Module

Polar Pattern

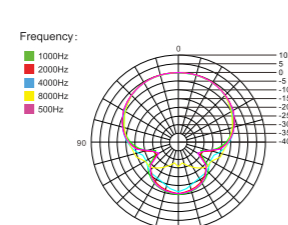

Connectivity:	Relacart UR series wireless handheld microphones Shure® wireless handheld microphones
Type:	Dynamic
Directivity:	Supercardioid
Frequency:	
Response:	100-18000Hz
Flexibility:	-53dB @ 1V/Pa
Dimension(mm):	Φ53×86
Weight:	145g

Frequency Response

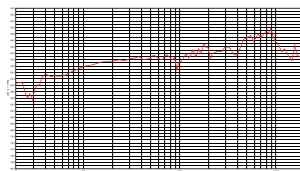

M-D30
Dynamic Microphone Module

Polar Pattern

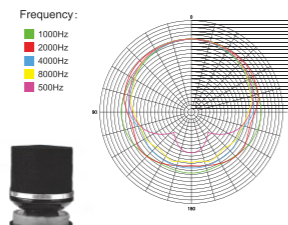

Connectivity:	Relacart HR series wireless handheld microphones
Type:	Dynamic
Directivity:	Cardioid
Frequency:	
Response:	100-18000Hz
Flexibility:	-47dB @ 1V/Pa
Max SPL:	145dB@1%
Dimension(mm):	Φ53×79
Weight:	115g

WIRELESS CAPSULES

Product Specification

Frequency Response

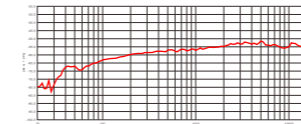

M-D32
Dynamic Microphone Module

Polar Pattern

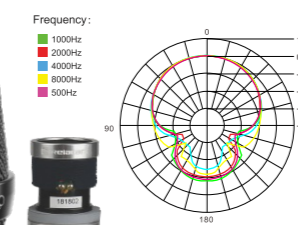

Connectivity:	Relacart HR series wireless handheld microphones Shure® wireless handheld microphones
Type:	Dynamic
Directivity:	Supercardioid
Frequency:	
Response:	45-18000Hz
Flexibility:	-57dB @ 1V/Pa
Max SPL:	600Ω
Dimension(mm):	Φ54×76
Weight:	150g

Frequency Response

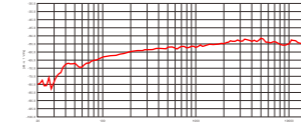

M-D33
Dynamic Microphone Module

Polar Pattern

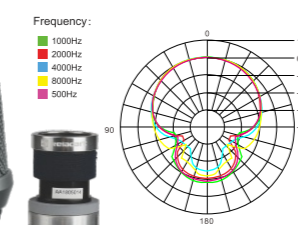

Connectivity:	Relacart H-33 wireless handheld microphones Sennheiser® wireless handheld microphones
Type:	Dynamic
Directivity:	Supercardioid
Frequency:	
Response:	45-18000Hz
Flexibility:	-57dB @ 1V/Pa
Max SPL:	600Ω
Dimension(mm):	Φ54×76
Weight:	155g

Frequency Response

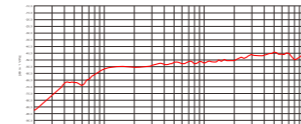

M-D35
Dynamic Microphone Module

Polar Pattern

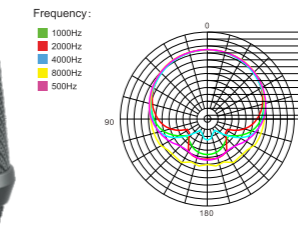

Connectivity:	Relacart H-33 wireless handheld microphones Sennheiser® wireless handheld microphones
Type:	Dynamic
Directivity:	Supercardioid
Frequency:	
Response:	70-16000Hz
Flexibility:	-55dB @ 1V/Pa
Impedance:	20Ω
Dimension(mm):	Φ54×76
Weight:	130g

Frequency Response

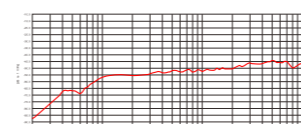

M-D36
Dynamic Microphone Module

Polar Pattern

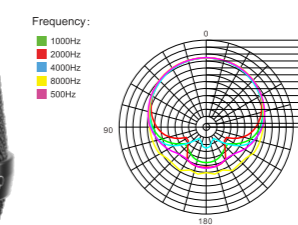

Connectivity:	Relacart HR/UR series wireless handheld microphones
Type:	Dynamic
Directivity:	Supercardioid
Frequency:	
Response:	70-16000Hz
Flexibility:	-55dB @ 1V/Pa
Impedance:	20Ω
Dimension(mm):	Φ54×76
Weight:	130g

WIRELESS CAPSULES

Product Specification

Simple and fast, let you have different sound quality

In order to meet the needs of our customers for performance products, each series of performance wireless microphones can have multiple replaceable microphone modules. Each module has different professional timbres and can be matched with different speakers to present sound effects. The microphone module can be replaced quickly, which is convenient for customers to replace microphones with all kinds of sound quality, and makes the maintenance of products easier and faster.

Frequency Response

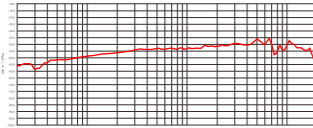

Polar Pattern

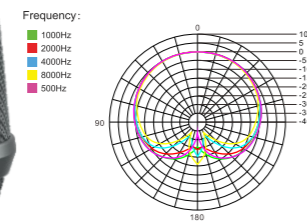

Connectivity:	Relacart HR series wireless handheld microphones Sennheiser® wireless handheld microphones
Type:	Condenser
Directivity:	Cardioid
Frequency	
Response:	100-18000Hz
Flexibility:	-43dB @ 1V/Pa
Max SPL:	145dB@1%
Dimension(mm):	Φ54×76
Weight:	155g

M-C37

Condenser Microphone Module

Frequency Response

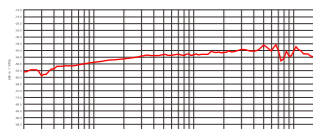

Polar Pattern

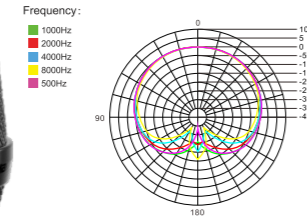

Connectivity:	Relacart HR/UR series wireless handheld microphones Shure® wireless handheld microphones
Type:	Condenser
Directivity:	Cardioid
Frequency	
Response:	100-18000Hz
Flexibility:	-43dB @ 1V/Pa
Max SPL:	145dB@1%
Dimension(mm):	Φ54×76
Weight:	150g

M-C38

Condenser Microphone Module

WIRELESS CAPSULES

Product Specification

RC-SHSE

Handheld Microphone Adapter
(Shure Head to Sennheiser Handheld)



Product size (mm):	41 (D)×14.5 (H)
Weight (g):	55

RC-SESH

Handheld Microphone Adapter
(Sennheiser Head to Shure Handheld)



Product size (mm):	41 (D)×14.5 (H)
Weight (g):	55

ACCESSORIES

Product Specification



RC-40N
Charging Case



RC-40N is for 40pcs AA batteries (battery for wireless microphone systems).
 Separate charging status indicator for each battery, flashing means being charging.
 Charging is completed within 5 hours and the charging status indicator lights red.
 Stop charging if batteries are not fully charged within 5 hours.
 Switching the charger's power OFF and back ON again with fully-charged charging completed batteries inserted will result in repeated recharge of the batteries. Battery life could deteriorate from this repetitive charging.
 Using Voltage: 100~240V.



Rechargeable Battery

- High capacity, low internal resistance, low self-discharge, one hour rapid charging and long cycle life.

Type:	Ni-NH battery
Cell Size:	AA
Dimensions:	13.9×49.5±0.5(mm)
Nominal Voltage:	1.2(V)
Nominal Volume:	1000-2600(mah)
Product certificate:	RoHS, CE, MSDS report

Rack Mount Kits



R-M1
Fits a single 1U Half-Rack receiver side-by-side, metal material.



R-M2
Fits dual 1U Half-Rack receivers side-by-side, metal material.



R-M3
Fits a single dual 2U centra controller, metal material.



R-M7
Magnetic BNC interface antenna bracket



R-M9
Fits dual 1U Half-Rack receivers side-by-side, metal material.



R-M10
Amplifier mounting bracket



P-12v10 DC 12V external power supply



MC-Pins Connecting Cable for conference system

ACCESSORIES

Product Specification



SI-2

Dual Channel Signal Isolator

DC Impedance:	127Ω at the input and 127Ω (1:1) at the output
AC Impedance:	600Ω at the input and 600Ω at the output (1:1)
Frequency Response:	20Hz-20KHz
Dynamic Range:	>110dB@1KHz
Distortion:	<0.03% @1KHz at +4dBu
Loss Attenuation:	-0.7 dB@1KHz
Maximum Input Level:	+4 dBu@20Hz at 1% +13 dBu @50Hz at 1% >30 dBu@1KHz at <0.15% THD
Isolation Voltage:	0-1250V
Input Interface:	XLR Female X2
Output Interface:	XLR Male X2 6.35mm jackX2
Switch:	A channel grounding switch, B channel grounding switch, A+B shielded case grounding switch
Dimensions (mm):	166 (W)×43.8 (H)×83 (D)
Weight:	0.5kg

SI-2 dual-channel professional passive audio isolator, aluminum alloy casting, exquisite and durable, EIA Standard 1U height, with rack mount kit can be installed in the flightcase, easy to use. Two-channel 6.35 and XLR input and output, can be converted and distributed to each other, each channel has a common ground and a non-common ground, and signal is not distorted, and eliminates external interference (a-c hum, high-frequency oscillation) and noise.

Audio signal isolators are widely used in broadcasting and television media transmission systems, audio and video system engineering, live audio sound reinforcement, audio signal through audio signal isolator, balanced and unbalanced can be converted to each other, can completely isolate the potential difference between the two systems, to avoid the audible interference caused by the grounding problem prevents the excessive potential difference from damaging the input stage of the device. Realize the safe transmission of audio signals, eliminate the noise generated by the connection of cameras and audio equipment, eliminate the noise generated by the simultaneous interpretation equipment and the mixer, eliminate the noise generated by the laptop connected to the mixer, eliminate the noise generated by the electronic instrument connected to the mixer and eliminate the noise generated by equipment and equipment over long distances; eliminate noise generated by equipment and equipment noise mismatch. Eliminate the sound of the site caused by electricity, wiring, lighting interference, etc.

Key Features

- Metal case, EIA Standard Rack 1U height, small size, easy to use.
- High-strength interference rejection, CMRR >90dB.
- Supports plug and play, supports hot plugging, no power supply, no software setup and maintenance.



interface function:

- A channel XLR female and 6.35mm jack dual-use balanced and unbalanced input.
- B channel XLR female and 6.35mm jack dual-use balanced and unbalanced input.
- The A channel switches.
- The B channel switches.
- A+B channel shielded case grounding switch.

- B channel XLR male output
- B channel 6.35mm jack balanced and unbalanced output
- A channel XLR male output
- A channel 6.35mm jack balanced and unbalanced output

ER-5900

DUAL CHANNEL TRUE DIVERSITY WIRELESS MICROPHONE SYSTEM



ER-5900 series is a dual-channel true diversity wireless microphone. True diversity receiving mode is more stable, with AFS function, eliminating the reception drop out problem. The frequency response is wide, the sound quality is rich and full, with strong vocal expression. cardioid directional pickup, high sensitivity, while reducing environmental noise. The tone is high fidelity. It is suitable for karaoke, bars, night clubs, KTV and other entertainment venues.

Key Features

AFS(Automatic Frequency Selection)

• AFS Automatic frequency selection, Press the [AFS] (Auto Frequency Selection) button 3S and the receiver will auto-scan and lock on to an open, interference-free frequency.

Anti-Interference

• Adopt true diversity FM super-heterodyne reception to ensure the stability of the received RF signal and the anti-interference of the receiver itself; the operating frequency range is from 521.25MHz to 936.85MHz.

Classic Audio Companding Circuit

• Matching the Relacart's classic audio companding circuit to minimize the noise from the transmission of radio waves, and to ensure the maximum pickup effect of the product in use.

Intelligent Design

• The handheld microphone adopts the latest auto-mute, auto drop-to-mute, auto-off function. when the microphone is put horizontal or less than 45 degree for 5 sec, the microphone will be auto-mute. When the microphone is static for 10 mins, the microphone will be auto-off. When drop down, the microphone will be auto-mute. Intelligent electricity-saving, humanized application.

• The receiver comes with the electronic volume adjustment, the adjustment range is -6dB to +18dB, +3dB step.

• The receiver can display the battery level of the transmitter and can change according to the battery level of the transmitter.

Reliable Signal

• The BNC antenna can be connected to the coaxial antenna and the extended antenna, and provides the antenna power supply voltage.

• It can be connected to the Relacart classic Antenna distribution system, expand the multi-device, enhance the receiving distance and improve the signal stability.

IR Infrared

• With [IR] infrared automatic frequency matching function, press the [SYNC] button, the transmitter can automatically and accurately lock the working frequency of the receiver.

Generality

• 134MHz wideband transmitter, four different frequency band receivers can be used interchangeably, which greatly facilitates KTV debugging and management.

• Channel group mode is selected, and 50 channel groups in each frequency band provide user selection.

Product Specification



ER-5900
Dual Channel Wireless Receiver

- EIA Standard Rack 1U metal rack receiver chassis.
- Bright LCD display can simultaneously display the working channel or frequency, RF & AF signal status, transmitter battery consumption as well as mute level.

Tuning Bandwidth:	521.25MHz-936.85MHz
Receiving Mode:	FM Superheterodyne true diversity reception
RF Sensitivity:	5dBμV, S/N>60dB at 25 deviation
Squelch:	10dB to 40dB, 5dB step
Frequency Sync:	IR Sync
Maximum Output Level:	Maximum output + 11dBV
Adjustment Range of Audio Output Level:	-6dB to +18dB, 3dB step
Power Requirements:	DC12V/1A
Current Consumption:	DV12V, 330mA
Overall Dimensions(mm):	410(W)×43(H)×206(D)
Net Weight:	1.8Kg

- It adopts new alloy material and new technology electroplating coating, which is resistant to falling and durable, not easy to fade, and remains as good as new after long-term use. It uses a left-right toggle switch design, which is easy to operate. The switch has undergone 10,000 tests, with high durability and low loss. The wireless microphone is equipped with an LED display, which can show the channel group, battery level and frequency. The tail cover adopts an anti-falling design. It is suitable for various occasions such as speeches, singing performances and KTV.

Switching Bandwidth:	521.25MHz-936.85MHz
Oscillation:	PLL synthesized
RF Output Power:	5mW/30mW
Carrier Deviation:	0.5KHz
Harmonic Radiation:	≤45dB
Modulation:	FM
Nominal/ Peak deviation:	±45KHz
Max. Input Level:	Maximum input - 11dBV
Frequency Set-Up:	IR Sync
Power Requirements:	2X AA 1.5V batteries
Battery Life:	>8 hours
Dimensions(mm):	50(Φ) × 260(L)
Net Weight (without battery):	About 330g

EH-6200
Wireless Handheld Microphone



ET-50
Wireless Bodypack Transmitter



- Bodypack-style wireless microphone, simple design, lightweight and practical engineering materials, durable, multi-function LCD display, built-in input selector switch, can be used to facilitate the instrument.
- The standard mini XLR microphone interface is suitable for a variety of well-known headset and clip microphones on the market. It is suitable for applications such as speech and singing.

Carrier Frequency Range:	521.25MHz-936.85MHz
Oscillation:	PLL Synthesized
Harmonic Radiation:	≤50dBm
Bandwidth:	134MHz (It depends on the region)
Max. Deviation Range:	±45KHz
Input Connector:	4-pin mini-XLR connector
RF Output Power:	20mW/2mW
Battery:	AA×2
Current Consumption:	110mA(Typical)
Battery Current/ Life:	Approximately 11 hours
Dimension(mm):	84(H)×66(W)×23(D)
Weight:	155g (w/o battery)

WIRED MICROPHONES



The VX-300 is a wired dynamic microphone equipped with a high-quality cartridge that delivers clear and natural sound. Its supercardioid pattern effectively focuses on the sound from the front while suppressing noise interference from the surrounding environment. With a standard XLR interface for plug-and-play, it is made of durable metal material, capable of withstanding bumps and drops during daily use. It is suitable for use in schools, enterprises, institutions, performances, and other occasions.



VX-300
Supercardioid Dynamic Microphone

- High-output design that matches human voice performance;
- Super-cardioid directional dynamic microphone head structure;
- Specially developed for timbres requiring mid-to-low frequencies;
- The robust and durable design ensures reliable performance;
- Durable and equipped with a dedicated magnetic control locking switch.

Capsule Type:	Dynamic
Voice coil Material:	Aluminum
Magnet Type:	Neodymium
Polar Pattern:	Supercardioid
Frequency Response:	50 Hz-18 kHz
Sensitivity:	-54±3 dBV/Pa
Output Impedance:	300 Ω±30%(at 1 kHz)
Output Connector:	3-pin XLR male connector
Switch:	Reed switch
Dimensions:	Φ: 52 mm(2.04 in.) L: 193 mm(7.59 in.)
Weight:	360 g

WIRED MICROPHONES



SM-300
Cardioid Dynamic Microphone

- High-output design for vocals that cut through the mix.
- Cardioid polar pattern reduces pickup of sounds from the sides and rear.
- Tailored for smooth, nature vocal reproduction.
- Rugged all-metal construction for reliable performance.
- Silent on-off operation thanks to vacuum magnetic switch.

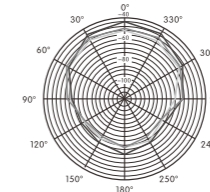

Polar Patterns

Capsule Type:	Dynamic
Polar Pattern:	Cardioid
Frequency Respond:	50Hz-14000Hz
Sensitivity:	-58dB+/-3dB(1V/Pa)
Output Impedance:	600Ω+/-30%(at 1KHz)
Switch:	Magnetic Lock switch
Output Connector:	Male 3-pin XLR
Size(mm):	51 (Φ) × 190 (L)
Weight(g):	Approximately 343

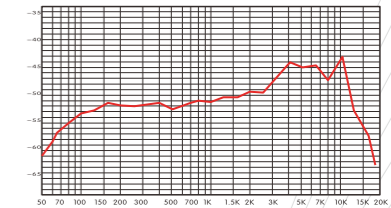

Spectrum Graph



PM-100
Professional Condenser Microphone

- According to the frequency characteristics of human voice, electroacoustic technology is applied to design and provide a clear reproduction of the original sound.
- It is especially suitable for professional performances on medium and small stage.
- The Cardioid directional pickup can effectively enhance the main sound source and suppress background noise.
- The microphone tube body is made of metal material, with low noise and strong durability.
- High strength anti-slip metal mesh can effectively protect the microphone from damage.
- The sound transmitting unit has the function of air filtration, and can eliminate the breath noise when singing.
- The structure of multi-layer head protection network can strengthen the protection of recording broken sound without affecting the quality of high-pitch sound.

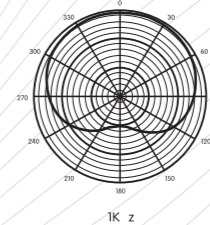

Polar Patterns

Capsule Type:	Condenser
Polar Pattern:	Cardioid Unidirectional
Frequency Respond:	50Hz-20kHz
Sensitivity:	-44 dB (1V/Pa)
Output Impedance:	280Ω
Max Windstand:	120dB, 1KHz at 1% T.H.D.
Sound Pressure:	115dB, 1KHz at max sound pressure(Typical)
Dynamic Range:	>72dB(A), 1KHz at 1Pa
S/N:	>72dB(A), 1KHz at 1Pa
Phantom Power:	11-52VDC
Current Consumption:	4mA(Typical)
Output Connector:	Male 3-pin XLR
Size(mm):	51 (Φ) × 190 (L)
Weight(g):	Approximately 365

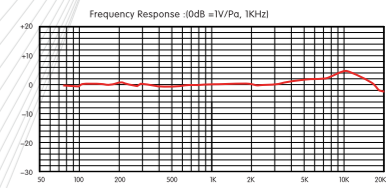

Spectrum Graph



KM-100
Cardioid Dynamic Microphone

- Cardioid polar pattern reduces pickup of sounds from the sides and rear.
- Excellent middle and low frequency sound tailored for KTV rooms
- Rugged, all stainless steel design and construction for years of trouble-free use.
- Silent on-off operation thanks to vacuum magnetic switch.

Capsule Type:	Dynamic
Polar Pattern:	Cardioid
Frequency Respond:	45Hz-14000Hz
Sensitivity:	-58dB+/-3dB(1V/Pa)
Output Impedance:	600Ω+/-30%(at 1KHz)
Switch:	Magnetic Lock switch
Output Connector:	Male 3-pin XLR
Size(mm):	49 (Φ) × 186 (L)
Weight(g):	Approximately 354

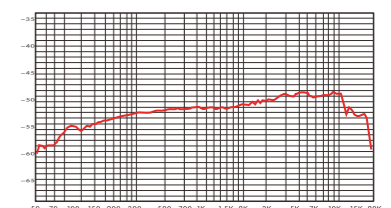

Spectrum Graph



The Relacart MiLIVE is a premium 1/2" small-diaphragm condenser microphone designed for applications such as studio recording and live performance on stage. It also provides ultra-low self-noise and a smooth, balanced sound. It features the supercardioid pattern and wide frequency response allow the MiLIVE to record the desired sound source while reducing the level of other surrounding instruments, noise or sound sources.

Key Features

Condenser Microphone

- Capacitive microphones have extremely high fidelity to the user's voice during recording, and the recorded sound is excellent in terms of sound quality, volume, and timbre compared to the original sound.

Stereo Array Mode

- It supports the use of multiple MiLIVE small diaphragm microphones according to different usage requirements and scenarios, and can form different stereo array modes.

Ultra-low Noise

- The characteristic of the cardioid directivity is that the sensitivity at the rear end is relatively weak, which can block part of the ambient sound.

XLR Output Connector

- The XLR output connector can be connected to other professional studio equipment or live streaming sound cards.

Hypercardioid pickup pattern

- The hypercardioid pickup pattern makes use of high sensitivity at the front end, which can better capture human voices and make them sound more pleasant and appealing.

Lightweight All-metal

- Made of lightweight metal, it is lighter than other microphones. It can more effectively protect the built-in circuit board, resulting in a longer service life.

48V 48V Phantom Power

- A phantom power supply ranging from 11V to 52V is required. It can be powered by the phantom power supply on the mixer, or by Relacart's P-48V1S single-channel phantom power supply.

Product Specification

Microphone Type:	Condenser microphone
Polar Pattern:	Supercardioid
Frequency Response:	50HZ-20KHZ
Maximum Input SPL:	130dB , 1KHz at 1% THD
S/N Ratio:	90dB , 1KHz at 1% THD.
Dynamic Range:	90 dB, 1 KHz at Max SPL
Sensitivity:	-45 dB at 1 V at 1 Pa
Dimensions (mm):	24 (Φ)×115 (L)
Weight (g):	125

MiLIVE Small-Diaphragm Condenser Microphone

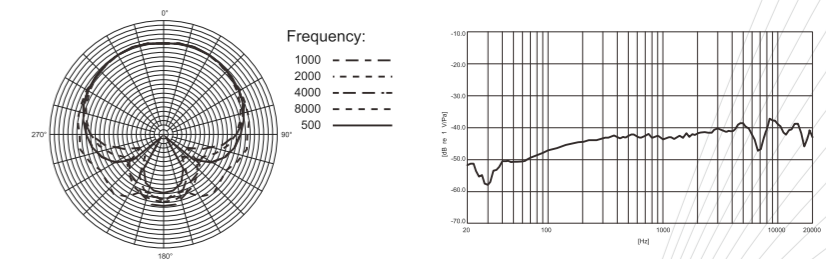

R-M18 Stereo Microphone Spacing Bar



Dimensions (mm):	260(L)×32(W)×54(H)
Weight (g):	210

- The Relacart R-M18 is a device that mounts two microphones in a stereo array and easily captures stereo sound, with clearly marked spacing up to 20cm, and angle and measurement metrics for ORTF and X-Y positioning.
- Featuring 3/8" mounting threads with included spacing clips for easy positioning of stacked arrays, the sturdy ABS construction makes the R-M18 Stereo Stand stable and durable, allowing it to easily support the weight of two large-diaphragm microphones.
- Suitable for Studio recording and stage live performance, etc.

Stereo Mounting Techniques

i Stereo X-Y

This stereo pickup mode has the advantages of more accurate vocal or instrumental sound and better mono compatibility.

ii Stereo ORTF

The advantage of this stereo pickup mode is that it can locate the sound more accurately.

iv Stereo spaced pair

This stereo pickup mode has the advantages of wide pickup range and low frequency response.

PRODUCT APPLICATION EXAMPLES --PROFESSIONAL PERFORMANCE

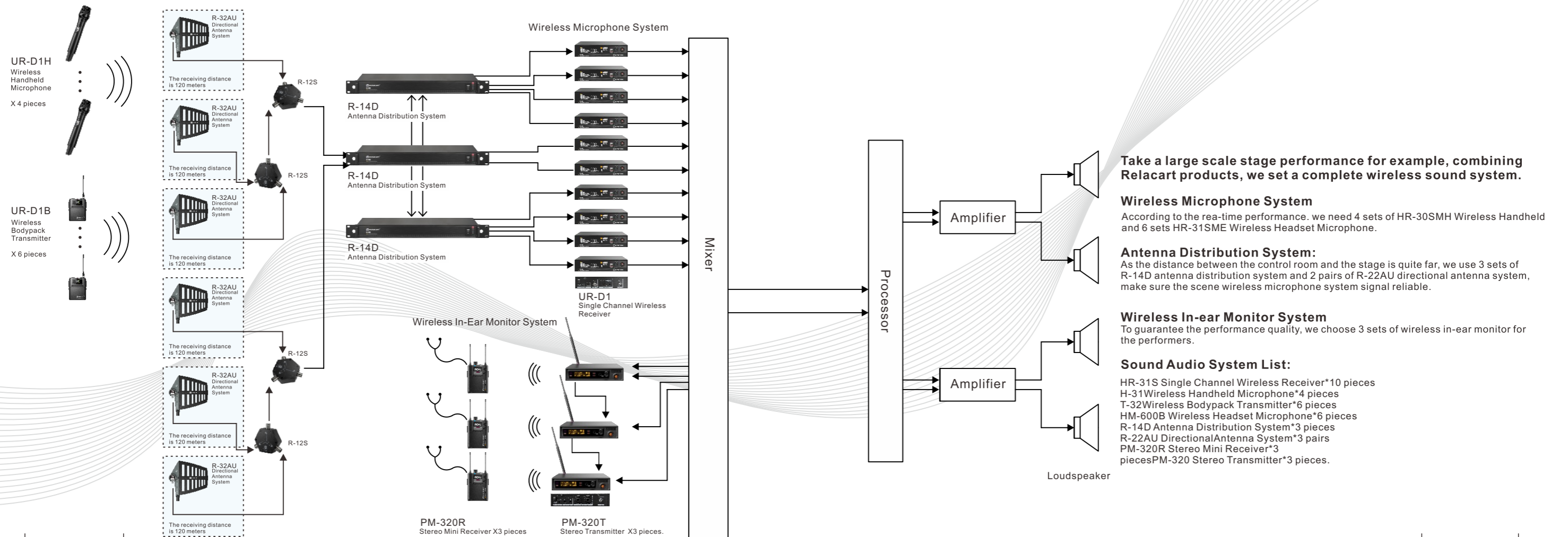

Take a large scale stage performance for example, combining Relacart products, we set a complete wireless sound system.

Wireless Microphone System
According to the rea-time performance. we need 4 sets of HR-30SMH Wireless Handheld and 6 sets HR-31SME Wireless Headset Microphone.

Antenna Distribution System:
As the distance between the control room and the stage is quite far, we use 3 sets of R-14D antenna distribution system and 2 pairs of R-22AU directional antenna system, make sure the scene wireless microphone system signal reliable.

Wireless In-ear Monitor System
To guarantee the performance quality, we choose 3 sets of wireless in-ear monitor for the performers.

- Sound Audio System List:**
- HR-31S Single Channel Wireless Receiver*10 pieces
 - H-31 Wireless Handheld Microphone*4 pieces
 - T-32 Wireless Bodypack Transmitter*6 pieces
 - HM-600B Wireless Headset Microphone*6 pieces
 - R-14D Antenna Distribution System*3 pieces
 - R-22AU Directional Antenna System*3 pairs
 - PM-320R Stereo Mini Receiver*3 pieces
 - PM-320T Stereo Transmitter*3 pieces.

DCS-303

WIRED DIGITAL CONFERENCE DISCUSSION SYSTEM

Product Specification

- A single central controller unit can connect up to 50 discussion units, with support for up to 6 central controller units and 300 discussion units operating simultaneously.
- The system uses standard network cables for signal transmission and supports PoE power supply, delivering uncompressed 24-bit/48kHz audio signals with low latency.



DCS-303
Central Controller

Chassis Specifications:	EIA Standard 1U
Sampling Rate:	24-bit/48kHz
Signal Latency:	>3ms
Frequency Response:	20Hz–20kHz (1kHz, +4dBu output)
Dynamic Range:	>100dB (A-weighted)
Signal-to-Noise Ratio:	95dB (A-weighted)
Total Harmonic Distortion:	<0.1% (f=1kHz)
Equivalent Input Noise:	MicLine 1-2, <-126dBu, Rs=150Ω
Residual Noise:	<-86dBu, A-weighted
Total Harmonic Distortion + Noise:	<0.1% (overall)
Crosstalk (1kHz):	>-80dB
Connection Cable:	Cat5e Type B network cable
Maximum Number of Conference Units:	300
Display Type:	LCD
Phantom Power:	DC +48V
Standby Power Consumption:	6W
Rated Power:	250W/48V
Maximum Power:	300W/48V
Power Supply:	AC 100–240V, 50/60Hz
Operating Temperature:	0°C to 60°C
Control Type:	Mechanical + Capacitive Touch
Dimensions(mm):	410 (W) × 43 (H) × 206 (D)
Weight:	3.4 kg

Relacart DCS-303 Wired Digital Conference Discussion System is a new-generation conference solution that integrates high-quality audio, strong expandability, and versatile functionality. Equipped with a built-in DSP chip and howling suppression, it effectively ensures speech clarity. A single central controller unit can connect up to 50 discussion units, with support for up to 6 central controller units and 300 discussion units operating simultaneously. The system uses standard network cables for signal transmission and supports PoE power supply, delivering uncompressed 24-bit/48kHz audio signals with low latency. It can be expanded with a simultaneous interpretation central controller, supporting one primary language and up to seven foreign languages for simultaneous interpretation. An optional voting function is also available to meet the needs of various types of conferences. The discussion units feature a 5-inch touchscreen for voting and independent sensitivity adjustment, along with a 7-band parametric equalizer (PEQ) for fine-tuning and AGC for automatic volume gain control. System parameters can also be configured via the WEB software developed by Relacart. Whether for large-scale conferences, government agencies, enterprises, hospitals, schools, or other scenarios, the DCS-303 delivers an exceptional speaking experience tailored to diverse meeting requirements.

Key Features

Ring Network Technology

- Features an innovative ring network design that enables fully digital signal transmission and processing. A single CAT5e cable is sufficient to transmit 1 primary + 7 interpretation audio channels along with various data.

WEB Software

- System parameters can be configured via dedicated WEB-based software. Users can access and adjust settings directly through any smart device's browser without installing additional software. Supports independent adjustment of microphone sensitivity and 7-band PEQ per unit, along with AGC for automatic volume gain control.

High-Fidelity Audio

- Utilizes lossless audio transmission technology with 24-bit/48kHz sampling and 20Hz-20kHz frequency response. Supports zoned audio output with automatic volume adjustment based on active microphone locations. Enables longer pickup distances without feedback. central controller supports 9-band output PEQ for sound field adjustment, compression, noise gate, AGC, and AFC automatic feedback suppression.

DSP DSP Chip

- Incorporates a high-speed DSP chip, 24-bit high-performance ADC/DAC, and proprietary digital audio extension algorithms to reduce noise during transmission.

Flexible Expansion

- Supports cascading multiple conference central controllers for larger venue merging/separating (including conference management). A single central controller connects 50 units, with up to 6 central controllers supporting 300 units total – perfectly scaling from small meetings to very large conferences.

Voting Function

- The system offers an optional professional voting module. Participants can cast votes directly via the unit's touchscreen, significantly enhancing meeting decision-making efficiency and transparency.

Simultaneous Interpretation

- The system can be expanded with an interpretation central controller to provide simultaneous interpretation, supporting up to 1 original language interpreted into 7 foreign languages. This meets international conference requirements and ensures clear cross-language communication.

Touchscreen

- Units feature 5-inch color touchscreens with intuitive interfaces. Participants can easily view operational status, voting information, and perform menu operations directly on screen for a smooth, modern user experience.

USB Interface

- Supports USB recording to flash drives with central controller monitoring and advanced noise cancellation for clearer recordings. Features TYPE-C USB output for bidirectional real-time communication with video conference endpoints or meeting transcription.



DCS-303C
Chairman Unit

DCS-303D
Delegate Unit

- The DCS-303C/D wired digital conference discussion unit is engineered with a compact yet robust metal housing. It utilizes standard network cables for both data transmission and power supply, while its XLR 3-pin interface ensures secure connectivity with Relacart GF-series or other brand gooseneck microphones. The unit captures voice with exceptional clarity and delivers high-quality 24-bit/48kHz digital audio output.
- Equipped with a 5-inch LCD touchscreen, the unit enables on-screen operation for parameter adjustments and voting functions. Designed for versatility, it is fully adaptable to a wide range of meeting environments.

Sampling Rate:	24-bit/48kHz
Frequency Response:	20Hz–20kHz (1kHz, +4dBu output)
Dynamic Range:	>105 dB (A-weighted)
Signal-to-Noise Ratio:	98 dB (A-weighted)
Equivalent Input Noise:	<-90 dBuV
Total Harmonic Distortion + Noise:	<0.1% (overall)
Phantom Power:	48V
Power Supply:	DC +48V
Power Consumption:	>5W
Operating Temperature:	0°C to 60°C
Dimensions(mm):	135 (W) × 148.3 (H) × 84.2 (D)
Weight:	670 g

WDC-903/943

WIRELESS CONFERENCE
DISCUSSION SYSTEM



Dante

WDC-903 digital wireless conference discussion system, with professional appearance design, perfect circuit composition and stable functional characteristics, can be cooperated with VTS-2000 automatic video tracking system and central control system to achieve functional diversification of modern high-tech conference. The data instruction of this wireless conference discussion system is transmitted by LoRa protocol. Audio works in UHF band. High fidelity circuit design can produce high quality sound effect. The system has anti-interference protection, which can effectively block the influence of computers, mobile phones and Bluetooth wireless devices in the environment. It is fully applicable to local government departments, business conference rooms, business venues and international conference centers.

Product Specification



WDC-903

Digital and Wireless Conference
Discussion Systems

- Bright OLED operation screen, with Chinese and English language menu selection, perfect function, easy operation.
- With Dante interface, it can communicate with any device with Dante to transmit audio.
- With VTS-2000 automatic video tracking system, can achieve conference video tracking function.

Main Frame Size:	EIA Standard Rack 1U
Receiving Channel:	Six Channels
Frequency Reliability:	±0.005%
Carrier Frequency Range:	UHF 521.25MHz-936.85MHz
Sampling Rate:	48KHz /24bit
Modulation:	FM
Operating Distance:	80M (in open space)
Oscillation:	PLL synthesized
Bandwidth:	32MHz
Max. Deviation:	±45KHz
S/N:	>100dB
THD:	<0.5%@1KHz
Frequency Response:	50Hz-18KHz
Output:	Balanced XLR-M, 2 RCA
Power Supply:	AC110-240V 50/60Hz
Dimension(mm):	480(W)×350(D)×43(H)
Weight:	Approximately 3.2 kg



WDC-903C
Wireless
Chairman Unit

WDC-903D
Wireless
Delegate Unit

- It is powered by detachable lithium battery, charged by WDC-903 special charging box, or charged directly by USB interface of conference unit.
- It can work continuously for 16 hours and stand by for up to 24 hours at full power.
- Bright OLED display can display battery capacity, speech mode, time limit and other working conditions at the same time.
- Super anti-interference ability of mobile phone.
- With a halo-type work indicator.
- Use high-quality capacitive condenser microphone head to achieve high-quality sound pickup.
- Wireless conference technology can easily build a temporary system, beautiful and neat, without any impact on the installation site.

Carrier Frequency Range:	521.25MHz-936.85MHz
Oscillation:	PLL synthesized
Harmonic Radiation:	<45dBm
Bandwidth:	134MHz
Max. Deviation:	±45KHz
Input Jack:	3-pin XLR jack
RF Output Power:	15mW
Power Supply:	Li-ion polymer rechargeable battery 3.7V/2900mA
Current Consumption:	120 mA (Typical) 60mA (Standby)
Working Time:	23 Hour(Classical) 48 Hour(Standby)
Weight:	910g
Dimension(mm):	162(L)×125(W)×54(H)

Key Features

Practical Function

- The system automatically searches interference-free channels and replaces them.
- Control up to 255 Wireless Discussion units, up to 5 wireless units can speak at the same time.
- Bright OLED operation screen, with Chinese and English language menu selection, perfect function, easy operation.
- Super anti-interference function can effectively block the impact of computer devices, mobile phones and Bluetooth devices in the environment.
- The conference unit can automatically select or manually start the power supply. When it chooses to turn on automatically, the central controller will send the instruction to the conference unit at the same time, which automatically turns on the power supply and works in the mode after receiving the instruction.

LoRa communication protocol and UHF audio transmission protocol

- Using LoRa protocol 433Mhz wireless control signal, UHF audio transmission technology.

Flexible Speech

- Four conference modes:
 - ① Time-limited Mode
 - ② First in First out Mode
 - ③ Application Mode
 - ④ Voice-activated Mode

Dante Audio Transmission Protocol

- With Dante interface, it can communicate with any device with Dante to transmit audio.

Expansibility

- With antenna interface, it can be used in conjunction with the antenna system of Relacart, and the transmission signal is very strong.
- Any number of wireless conference systems can be installed in the same building.
- With VTS-2000 automatic video tracking system, can achieve conference video tracking function.
- Equipped with RS-232 interface, it can connect various central control devices.

Easy Installation

- The unique advantages of simple installation, easy and fast, and no impact on the installation site, especially for the installation or layout of historical museums, ancient buildings and other historical and cultural buildings, users need not worry about damage to ancient buildings, because they do not need wiring, nor drilling holes, providing a professional perfect solution for harsh and complex application occasions.



WDC-943C
Wireless Array Chairman Unit



WDC-943D
Wireless Array Delegate Unit



DC-903
Data Communication
Converter

- The wireless array microphone adopts a metal streamlined desktop design with OLED display. The array microphone has an ultra-long pickup distance of 80CM and a deeper pickup range, and its directional characteristics are significantly improved compared to ordinary cardioid microphones.

Carrier Frequency Range:	521.25MHz ~ 936.85MHz
Oscillation Mode:	PLL synthesized
Bandwidth:	134MHz
Max. Deviation:	±45KHz
RF Output Power:	30mW
Power Supply:	Lithium-ion polymer rechargeable battery

- DC-903 is a data communication converter for the WDC series wireless conference system.
- With mature and stable wireless communication protocol, LoRa it has the advantages of high stability, high performance, high security, low latency and low power consumption.

Working Frequency Range:	400~450MHz
Gain:	16dBm
RF Input Port:	N female
Data Communication Port:	RJ45 connector
Power Supply:	Powered by the controller through the CAT5 cable
Material:	Black anodized aluminum (package)
Dimension(mm):	42(W)×42(D)×105(H)
Weight:	150g

WDC-923/933

WIRELESS CONFERENCE DISCUSSION SYSTEM



WDC-923 digital wireless conference discussion system, with professional appearance design, perfect circuit composition and stable functional characteristics, can be cooperated with VTS-2000 automatic video tracking system and central control system to achieve functional diversification of modern high-tech conference. The data instruction of this wireless conference discussion system is transmitted by LoRa protocol. Audio works in UHF band. High fidelity circuit design can produce high quality sound effect.

Key Features

Practical Function

- The system automatically searches interference-free channels and replaces them.
- Control up to 255 Wireless Discussion units, up to 5 wireless units can speak at the same time.
- Bright OLED operation screen, with Chinese and English language menu selection, perfect function, easy operation.
- Super anti-interference function can effectively block the impact of computer devices, mobile phones and Bluetooth devices in the environment.
- The conference unit can automatically select or manually start the power supply. When it chooses to turn on automatically, the central controller will send the instruction to the conference unit at the same time, which automatically turns on the power supply and works in the mode after receiving the instruction.

LoRa communication protocol and UHF audio transmission protocol

- Using LoRa protocol 433Mhz wireless control signal, UHF audio transmission technology.

Flexible Speech

- Four conference modes:
 - ① Time-limited Mode
 - ② First in First out Mode
 - ③ Application Mode
 - ④ Voice-activated Mode

Dante Audio Transmission Protocol

- With Dante interface, it can communicate with any device with Dante to transmit audio.

Expansibility

- With antenna interface, it can be used in conjunction with the antenna system of Relacart, and the transmission signal is very strong.
- Any number of wireless conference systems can be installed in the same building.
- With VTS-2000 automatic video tracking system, can achieve conference video tracking function.
- Equipped with RS-232 interface, it can connect various central control devices.

Easy Installation

- The unique advantages of simple installation, easy and fast, and no impact on the installation site, especially for the installation or layout of historical museums, ancient buildings and other historical and cultural buildings, users need not worry about damage to ancient buildings, because they do not need wiring, nor drilling holes, providing a professional perfect solution for harsh and complex application occasions.

Product Specification



WDC-923

Digital and Wireless Conference Discussion Systems

- Bright OLED operation screen, with Chinese and English language menu selection, perfect function, easy operation.
- With Dante interface, it can communicate with any device with Dante to transmit audio.
- With VTS-2000 automatic video tracking system, can achieve conference video tracking function.

Main Frame Size:	EIA Standard Rack 1U
Receiving Channel:	Six Channels
Frequency Reliability:	±0.005%
Carrier Frequency Range:	UHF 521.25MHz-936.85MHz
Sampling Rate:	48KHz/24bit
Modulation:	FM
Operating Distance:	80M (in open space)
Oscillation:	PLL synthesized
Bandwidth:	32MHz
Max. Deviation:	±45KHz
S/N:	>100dB
THD:	<0.5%@1KHz
Frequency Response:	50Hz-18KHz
Output:	Balanced XLR-M, 2 RCA
Power Supply:	AC110-240V 50/60Hz
Dimension(mm):	480(W)×350(D)×43(H)
Weight:	Approximately 3.2 kg

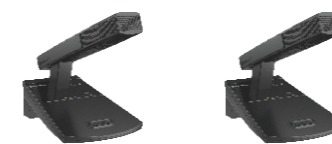

WDC-923C
Wireless Chairman Unit

WDC-923D
Wireless Delegate Unit

- It is a desktop conference microphone, it uses a new square microphone tube and a supercardioid condenser capsule to accurately pick up sound and reduce the interference noise of environmental.
- The indicator light has an RGB LED that shows the mode status. The factory default color is red for mute and green for sound pickup, and users can also change different colors to suit their preference.

Carrier Frequency Range:	521.25MHz-936.85MHz
Oscillation:	PLL synthesized
Harmonic Radiation:	<45dBm
Bandwidth:	134MHz
Max. Deviation:	±45KHz
RF Output Power:	30mW
Power Supply:	BP-10Li Li-ion polymer rechargeable battery 3.7V/2900mA
Current Consumption :	120 mA (Typical) 60mA (standby /mute)
Working Time:	23 Hours(typical) 48 Hours(standby /mute)
Dimension(mm):	162(L)×125(W)×54(H)
Weight:	910g



WDC-933C
Wireless Chairman Unit

WDC-933D
Wireless Delegate Unit

- VTS-2000 Video Tracking System can be used in conjunction with any conference system with video function of Relacart to realize video tracking function. When the speaker unit opens the microphone, the camera will automatically track the speaker's position, and connect the video display device to display the image. Unique picture static function, can achieve perfect automatic tracking image function.

Equipment Type:	HD Video Main Controller
Working Power:	AC 100-240V, 50/60Hz
Frequency Response:	143Mb/s to 2.97Gb/s
Gain:	0dB
Signal Type:	SDI(HD digital signal) HD cctv1.0 HD-SDI(ST292) 3G-SDI(ST424) SD-SDI(259)
Input Return Loss:	21dB@5MHz-3GHz
Video Input:	800mVp-p
Video Output:	800mVp-p
Compatible Standard:	Pelco-D pelco-P Visca
Control Protocol:	RS-232 RS-422 RS-485
Baud Rate:	9600
Data Bits:	8 Bits
Video Input/Output Impedance:	75Ω
Input/Output Port:	BNC
Dimension(mm):	410(W)×206(D)×43(H)
Weight:	Approximately 2.3 kg

VTS-2000

Video Tracking System



DC-903

Data Communication Converter

- DC-903 is a data communication converter for the WDC serie wireless conference system
- With mature and stable wireless communication protocol, LoRa it has the advantages of high stability, high performance, high security, low latency and low power consumption

Working Frequency Range:	400-450MHz
Gain:	16dBm
RF Input Port:	N female
Data Communication Port:	Rj45 connector
Power Supply:	Powered by the controller through the CAT5 cable
Material:	Black anodized aluminum (package)
Dimension(mm):	42(W)×42(D)×105(H)
Weight:	150g

Application:



Application Schematic Diagram:



- ①R-32AU
- ②R-32AU
- ③R-43W
- ④WDC-903 Chairman Unit
- ⑤WDC-903 Delegate Unit

System Connection Diagram

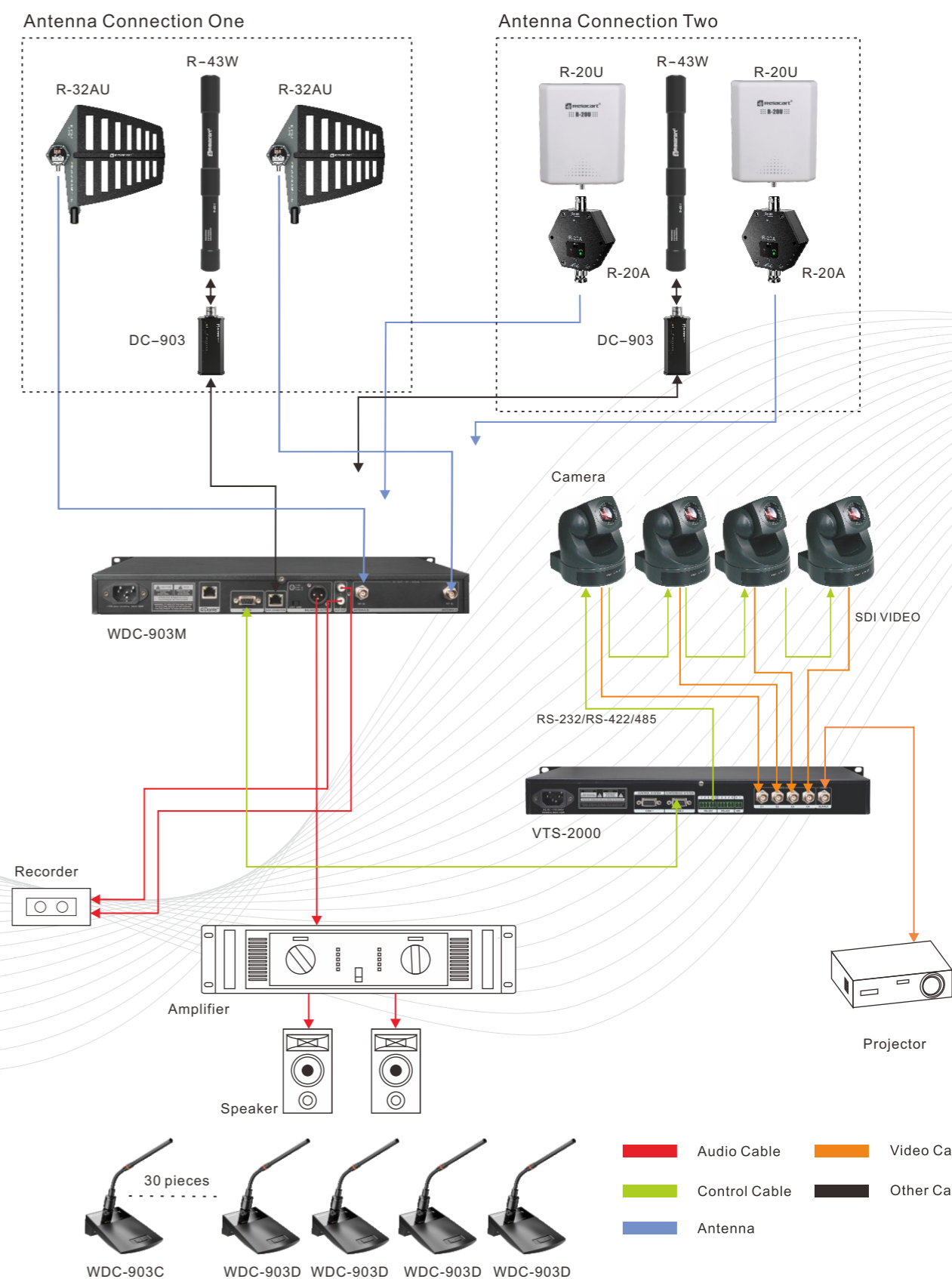

WAM-432

WIRELESS AUTOMATIC MIXER



WAM-432 Wireless Automatic Mixer is the new generation series product made by Relacart, who has strong R & D strength, used high performance microcomputer processor as core design. Professional and novel appearance, comprehensively combine digital control technology with advanced audio processing technology and network technology, intelligent control, fully automatic operation. With desktop and handheld, bodypack, boundary type transmitter for choice, can adapt to different applications of flexible configuration. Cooperate with Relacart VTS-2000 Video Tracking System to realize automatic video tracking function. This model apply to high requirement multi-function room, small to medium performance occasions, boardrooms, business meetings, educational institutions, hotels, conference rental, system reconstruction, etc.

Key Features

Practical Function

- Automatic gain adjustment by microprocessor control.
- True diversity receiving for best reception quality. "NoiseStop" circuits prevent interference.
- Circuit design of high fidelity can automatically calculate the most suitable for the whole system gain, avoid the feedback.
- Microphone input gain is adjustable. UB-222 and UD-222 is set with low-cut switch, applying to different environment.
- Output level is adjustable.

Flexible Expansion

- Cascaded connection function, can daisy chain up to 8 pieces of WAM-432, 32 microphone delegate can be used at the same time.
- Make the setting in one of the receivers, the data will be synchronized to the other receiver of cascade, wireless intelligent mixer is equivalent to a table up to 32 channels.
- Video tracking function. Combine VTS-2000 video tracking system to realize the function.
- Central control function to control the delegate.

Flexible configuration

- The encoder is configured and flexibly combined with the four touch switch to operate various functions and parameter settings. 128×64 OLED display can display various information of receiver and transmitter at the same time.

Flexible Speech

- Speaker Number Limitation function, select the simultaneous open microphones to 1 unit, 2 units, 3 units or 4 units.
- Last microphone on selectable for continuous room ambiance.
- Microphone hold time for 0.1s-1s.
- Priority microphone function

Super Wide Frequency Range

- 134MHz super wide band width, over 500 selectable UHF frequencies, true diversity receiving, reliable and anti-interference.
- Super wide frequency range UHF554MHz~936 MHz
- Group type frequency selection, more easily select no intermodulation interference frequency.

A variety of Input and Output

- Several inputs / outputs for audio signals:
 - RCA outputs to realize long distance with low noise transmission.
 - RCA inputs / outputs for recordings.
 - Unbalanced line outputs (6.3mm jack).
 - Balanced XLR outputs.

Easy Installation

- Convenient installation, simple operation. No need to dig holes or lain lines, can install the system on the spot for real time setting.

Product Specification



WAM-432

Digital & Wireless Automatic Mixer

- EIA Standard Rack 1U metal chassis, combining with delicate OLED display aluminium alloy panel, professional and elegant.
- Backlit OLED display shows microphone status, operation mode, master working status, speaker numbers, AF audio signal.
- Equipped with handle, easy for lift or move.

Carrier Frequency Range:	521.25MHz~936.85 MHz
Receiving Channel:	4 Channel
Receiving Mode:	True Diversity
Frequency Reliability:	0.005 %
Bandwidth:	32MHz
Receiving Mode:	FM
Receiving Sensitivity:	5dBμV, S/N>60dB at 25 KHz deviation
Max. Deviation Range:	±45KHz
Distortion:	<0.9% @1KHz
Frequency Response:	65Hz-16KHz ±3dB
S/N:	>100dB
Audio Output:	XLR socket
Data Port :	RJ11
Communication Port:	RS-232
Power Supply:	DC 12V / 1000mA
Dimension(mm):	410(W)×206(D)×43(H)
Weight:	2.5kg

UD-222

Wireless Conference Microphone



- Desktop gooseneck wireless conference microphone, simple design, durable metal material, multi-function OLED display, built-in high-pass filter and gain adjustment, silent touch switch. Suitable for various applications in government departments, institutions, etc.

Carrier Frequency Range:	470MHz~936.85MHz
Oscillation:	PLL Synthesized
Harmonic Radiation:	≤50dBm
Bandwidth:	134MHz(It depends on the region)
Max. Deviation Range:	±45KHz
RF Output Power:	20mW/2mW
Volume Potentiometer:	-10~10dB
Low Cut Switch:	200Hz below
Battery:	AAx2
Current Consumption:	130mA(Typical)
Battery Current/ Life:	Approximately 9 hours
Dimensions (mm):	145(L)×115(W)×48(H)
Microphone Lengths(mm):	340/420(default)/480
Weight:	Approximately 830g (w/o battery)

UD-223

Wireless Conference Microphone



- UD-223 is a desktop gooseneck wireless conference microphone base with simple design style, solid and durable metal material, and silent touch switch.

Carrier Frequency Range:	521.25MHz~936.85MHz
Oscillation:	PLL Synthesized
Harmonic Radiation:	≤50dBm
Bandwidth:	134MHz(It depends on the region)
Max. Deviation Range:	±45KHz
RF Output Power:	10mW
Volume Potentiometer:	-10~10dB
Low Cut Switch:	200Hz below
Battery:	AAx4
Current Consumption:	180mA(Typical)
Battery Current/ Life:	Approximately 9 hours
Dimensions (mm):	170(L)×129(W)×49(H)
Microphone Lengths(mm):	340/420(default)/480
Weight:	Approximately 580g (w/o battery)

UD-903

Wireless Conference Microphone



- Desktop gooseneck wireless conference microphone, simple design, durable metal material, multi-function OLED display, built-in high-pass filter and gain adjustment, silent touch switch. Suitable for various applications in government departments, institutions, etc.

Carrier Frequency Range:	521.25MHz~936.85MHz
Oscillation:	PLL synthesized
Harmonic Radiation:	<45dBm
Bandwidth:	134MHz
Max. Deviation:	±45KHz
Input Jack:	3-pin XLR jack
RF Output Power:	15mW
Power Supply:	Li-ion polymer rechargeable battery 3.7V/2900mA
Current Consumption:	120 mA (Typical) 60mA (Standby)
Working Hour:	23 Hour(Classical) 48 Hour(Standby)
Dimension(mm):	162(L)×125(W)×54(H)
Weight:	910g

UB-222

Wireless Boundary Microphone



- The microphone switch can control or be controlled by external automatic central control system or other devices.
- Superior off-axis rejection for maximum gain before feedback.

Carrier Frequency Range:	470MHz~936.85 MHz
Modulation:	FM
Harmonic Radiation:	<45dBm
Bandwidth:	134MHz(It depends on the region)
Max. Deviation Range:	±45KHz
Elements:	Fixed-charge back plate, permanently polarized condenser Cardioid (120° sound-pickup angle)
Polar Pattern:	Cardioid (120° sound-pickup angle)
RF Output Power:	25mW/4mW
Dynamic Range:	>95dB, A Weighting
Audio Potentiometer:	-10~10dB
Frequency Response:	50Hz-17KHz
Low-cut Switch:	200Hz/-6dB
Battery:	AAx2
Current Consumption:	130mA(Typical)
Battery Current/Life:	Approximately 9 hours
Dimension (mm):	110(W)×110(D)×40(H)
Weight:	Approximately 505g

System Connection Diagram

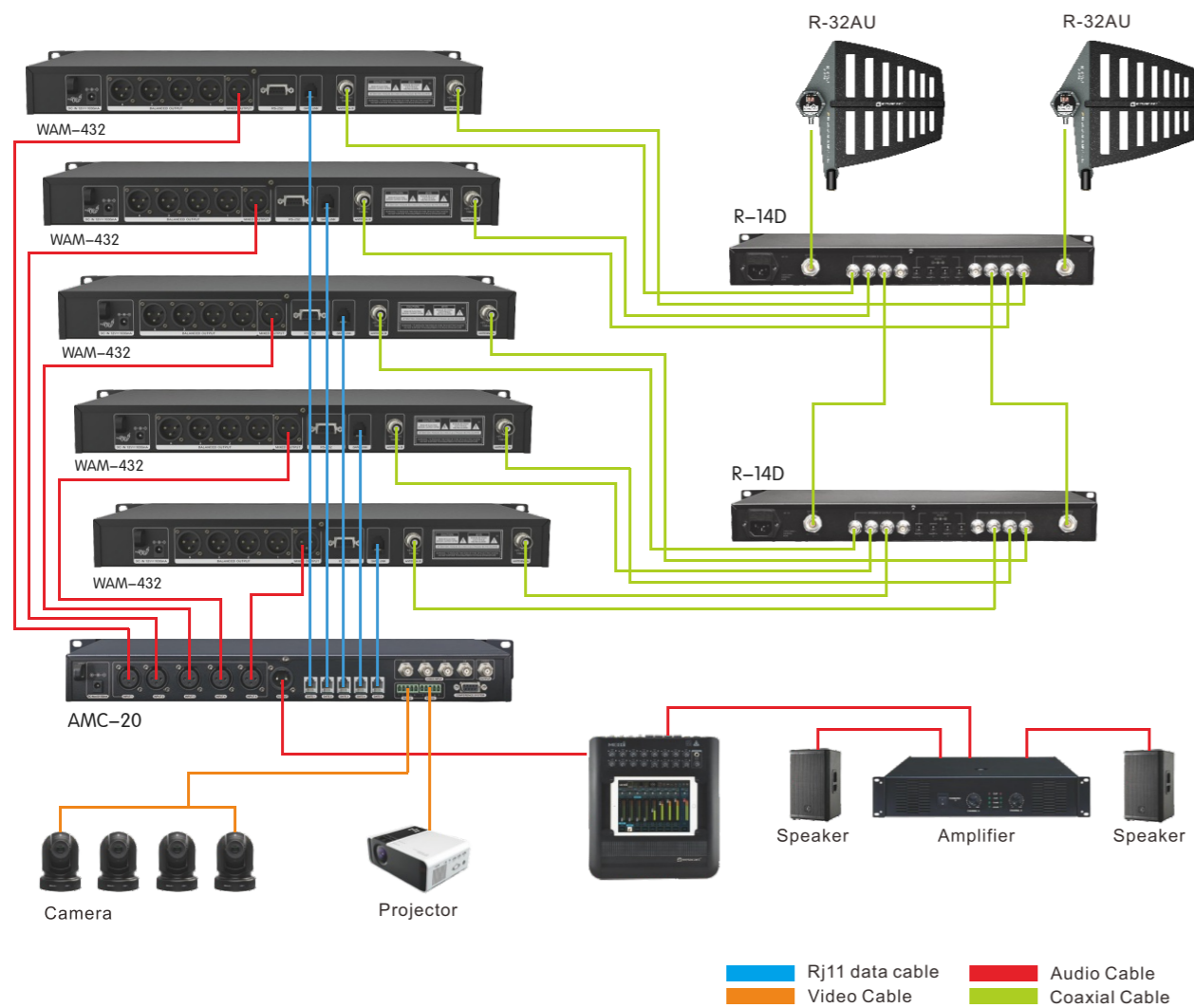

System Connection Diagram

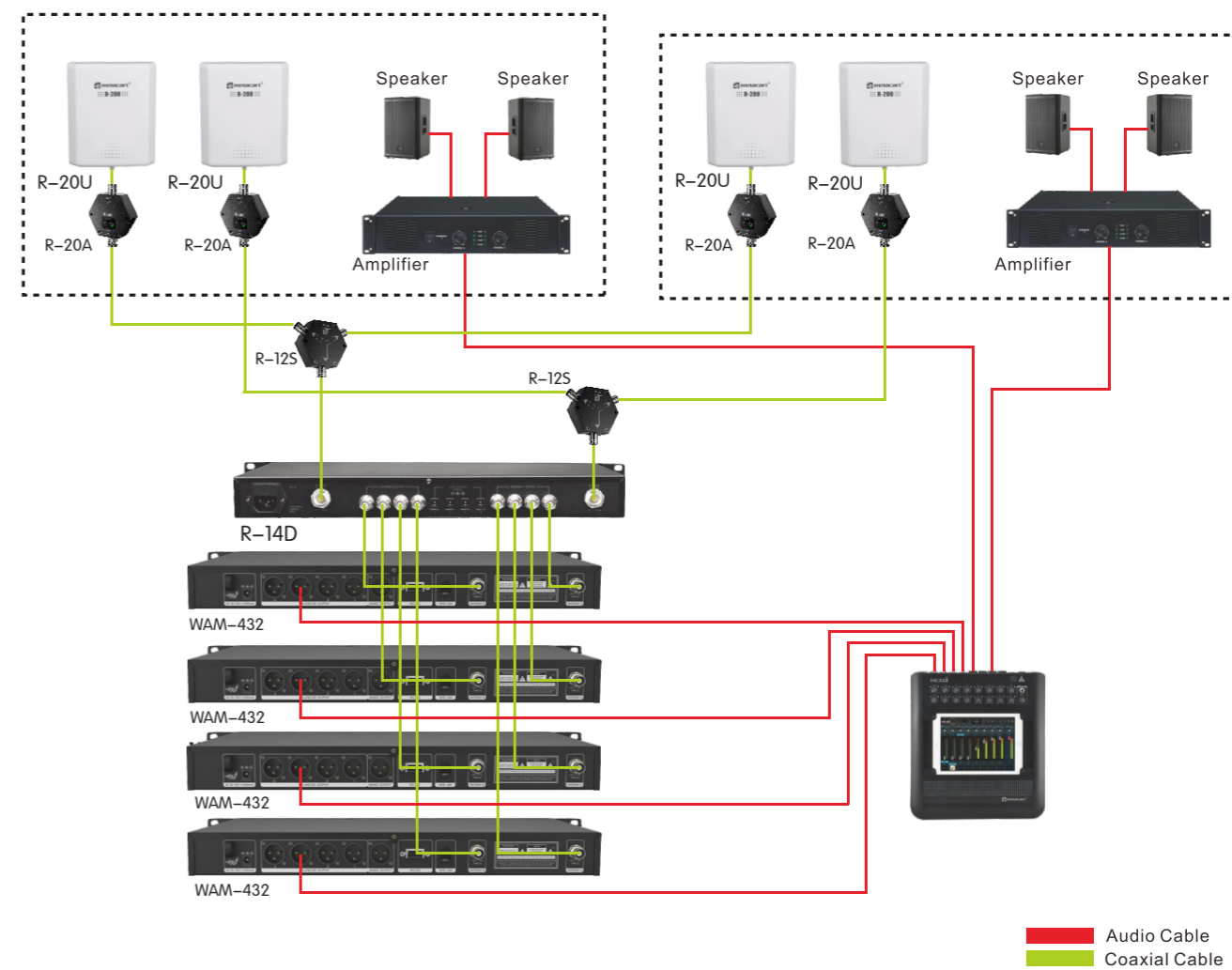

Application:



Application:





Key Features

- EIA standard Rack 1U metal.
- Front panel with 256x64 dot matrix OLED display and setting touch key, camera control key.
- Rear panel with DC-12V power supplier, 5 channels balance audio mixing input and 1 channel balance mixing output. 5 channels mixing data RJ11 interface, 4 channels high definition video input and 1 channel high definition video output, two camera control interface(RS-232 and RS-422), external RS-232 interface.
- Support the mixer data control and audio mixing connection, high definition camera connection. Constitute audio, video and the central control device. Cascade up to 5 mixers and 4 high definition cameras.
- Support the system automatic frequency calculation. The cascaded wireless mixers can be automatic calculate and setting the noninterference frequency, it can provide up to 20 clean frequencies.

Product Specification



AMC-20
Automatic Mixing Controller

- Support mixer data control, audio mixing connection, HD camera connection.
- It can support 20 mixers and 4 HD cameras.
- Support system automatic frequency calculation.

Power Supply:	DC 12 V
Current:	0.23A
Frequency Response:	20 Hz to 20 kHz+0/-1dB
Total Harmonic Distortion:	<0.03% (f=1KHz)
S/N Ratio:	>98 dB (THD<1%, f=1KHz)
Dynamic Range:	98dB
Video Input:	BNC female
Video Output:	BNC female
Video Interface Impedance:	75 ohms
RS-232 control protocol interface:	5P fast connection
RS-422 control protocol interface:	5P fast connection
RS-232 control protocol interface:	9-pin serial port
Data Interface:	Rj11
Audio Output:	XLR female
Audio Input:	XLR male
Display Type:	OLED
Button Mode:	Touch Button
Dimensions (mm):	410(W)×206(D)×43(H)

System Connection Diagram

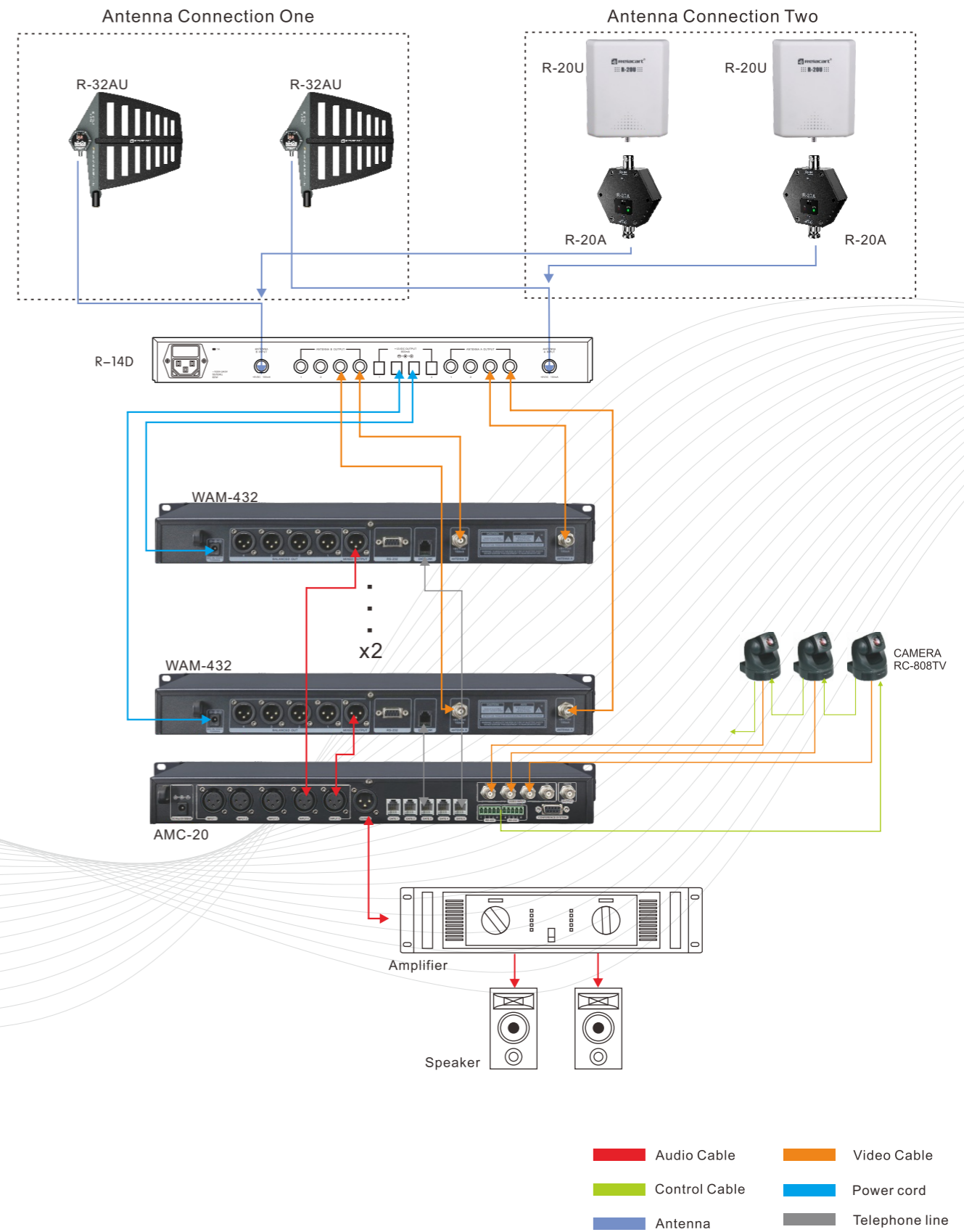

CS-302

CONFERRING DISCUSSION SYSTEM WITH DANTE NETWORK INTERFACE



CS-302 is a simple and affordable conference discussion system. With exquisite design, focusing on application of various conferences, the newly developed sound activate mode, the participants don't need operating manually, just speaking to microphones directly, the microphone unit can be started to speak, simple to use, fully applicable to the various conference locations. This system is composed of software and hardware, adopt microprocessor control, the unit automatically detect settings, innovation speaking mode setting, limiting times setting, and implementation of system video preset functions. As a new generation of multi function, can be separated from the computer to use, convenient operation of the video tracking discuss conference system, is the ideal solution for conference engineering application.

Key Features

Practical Function

- Adopt the OLED display, can display the microphone status, operating mode, central controller status, the number of speaker, etc.
- 4 kinds of conference mode selection: FIFO, Automatic(with limiting time), Request, Sound activate.
- The central controller can select the number of speakers, active 2/3/4 microphones in a time.
- Support camera tracking, through the serial port RS-232 or RS-422 communication protocol control up to 4 cameras, compatible with VISCA, PELCO-D, PELCO-P 3 kinds of camera control code protocol.
- With 4 video inputs and 1 video output port, SD and HD SDI video inputs and outputs are supported. HD SDI supports HDcctv1.0, HD-SDI (ST292), 3G-SDI (ST424) and SD-SDI (259).
- 9-pin serial port control interface can be connected to intelligent control system for camera tracking.
- The newly developed high-voltage, low-current power supply system minimizes line voltage losses and minimizes the effects of overly long connecting cables. One cable to connect more conference units makes installation easier.
- Adopt using anti shedding aviation cable hand in hand connection mode, the connection is simple, reliable and stable, the whole system required engineering and installation costs can be reduced.

Dante Audio Transmission Protocol

- Support Dante protocol, flexible to meet various engineering solutions.

Flexible Expanding

- It is easy to expand and change configuration. The central controller connect up to 30 microphone units. If connect the EXP-124W, can connect up to 110 microphone units.
- Connecting telephone coupler can be applied directly to a remote call meeting.

Flexible Speaking

- CS-302C and CS-501C chairman unit has the priority to override all delegate units, to control the atmosphere of the meeting.

Four Speech Mode:

- ① Time limiting: The speech time limit can be set to 1-60 minutes, and the speech will be automatically closed when the time is up. After reaching the power-on quantity, when another representative wants to speak, it will automatically enter the request-to-speak registration queue.
- ② FIFO: FIFO mode (default). After reaching the power-on number, the speaking unit that was opened first is closed by the subsequent speaking unit.
- ③ Request: The speaking of the representative unit needs to be approved by the chairman unit or the operator. In this mode, the chairman unit always keeps the normally open state.
- ④ Voice Activated: When the microphone is turned on by voice, manual operation is not required. After the number of power-on is reached, the speaking unit that is turned on first is turned off by the subsequent speaking unit.

Multiple Ports

- With record output can connect the recorder, all records can be fully recorded and saved, also can connect the external audio device.
- With anti drop 9P aviation plug and Cat5 TypeB network port

Clear Sound Quality

- With automatic gain audio processing circuit, prevent feedback effectively and improve the clarity of the whole system.

Product Specification



CS-302M

Central Controller



CS-302C

Chairman unit

CS-302D

Delegate Unit



CS-302CN

Chairman unit

CS-302DN

Delegate Unit



CS-501C

Chairman unit

CS-501D

Delegate Unit



CS-N1C

Chairman unit



CS-N1D

Delegate Unit

Chassis Specifications:	EIA Standard Rack 1U
Supply Voltage:	90-264V AC or 127-370V AC, 47-63Hz
Static Power Consumption:	6W
Rated Power:	75W/24V
Maximum Power:	100W/24V
XLR Balances Canon Maximum Output Level:	14.6dBu
Maximum output level of the 6.35mm balance socket:	14.6dBu
RCA lotus socket maximum output level:	9.8 dBu
RCA lotus socket maximum input level:	3.2 dBu
Conference Unit Extension:	Anti drop 9P aviation plug x 1, Network port (female) x1
Video Input Port:	BNC x 4
Video Output Port:	BNC x 1
Video Interface Impedance:	75Ω
9 pin serial port control interface:	Db9 Female plug x 1
Rs-232 control protocol interface:	5P Phoenix terminal X 1
Rs-422 control protocol interface:	5P Phoenix terminal X 1
Dante Interface:	Rj45x1
Audio Output:	XLRM x 1, 6.35mm jack x 1, RCA x 1
Audio Input:	RCA x 1
Screen Type:	OLED
Key Mode:	Touch style
Dimension (mm):	410 (W)×206 (D)×43 (H)
Weight:	Approximately 2.3kg

CS-302C/D CS-302CN/DN RJ45 version) adopts the newly developed voice control mode, which enables the participants to start the microphone unit to speak without manual operation and directly speaking to the microphone. It is simple to use and fully applicable to various conference occasions.

Polar Pattern:	Cardioid Condenser
Frequency Response:	50Hz-18KHz
Sensitivity:	50Hz-18KHz
SPL:	105dB(THD<5%, f=1KHz)
S/N (A weighted):	>100dB(THD<1%, f=1 KHz)
Distortion:	<0.1%
Power Supply:	24V DC(supplied by the receiver)
Maximum Power of Speakers:	1.5W
Power Consumption:	0.8W-2.5W
Phone Connector:	3.5mm jack
Screen Type:	OLED
Unit Interface:	Anti drop 9P aviation plug
The length of microphone(mm):	340/420/480
The size of the microphone base:	182(L)×110 (W)×51(H)
Weight:	Approximately 950g
Color:	Nickel black

CS-501 C/D adopts the newly developed voice control mode, so that participants can start the microphone unit to speak directly without manual operation. It is simple to use and fully applicable to various conference occasions.

Polar Pattern:	Cardioid Condenser
Frequency Response:	50Hz-20KHz
Sensitivity:	-20dB+/-3dB(0dB=1V/Pa,f=1KHz)
SPL:	110dB(THD<5%, f=1KHz)
S/N(A weighted):	>100dB(THD<1%,f=1 KHz)
Distortion:	<0.1%
Power Supply:	24V DC(supplied by the central controller)
Power Consumption:	0.72W
Unit Interface:	RJ45/CAT5 network port
Dimension (mm):	147 (L)×115 (W)×218 (H)
Weight:	Approximately 670g



CS-360 is a simple and affordable Conference discussion system. With exquisite design, focusing on application of various conferences, the newly developed sound activate mode, the participants don't need operating manually, just speaking to microphones directly, the microphone unit can be started to speak, simple to use, fully applicable to the various conference locations.

Product Specification



CS-360
Central Controller

Chassis Specifications:	EIA Standard Rack 1U
Supply Voltage:	90-264V AC or 127-370V AC , 47-63Hz
Static Power Consumption:	6W
Rated Power:	6W
Maximum Power:	100W/24V
XLR Balances Canon Maximum Output Level:	14.6dBu
Maximum output level of the 6.35mm balance socket:	14.6dBu
RCA lotus socket maximum output level:	9.8 dBu
RCA lotus socket maximum input level:	3.2 dBu
Conference Unit Extension:	Anti drop 9P aviation plug x 1, Network port (female) x1
Video Input Port:	BNC x 4
Video Output Port:	BNC x 1
Video Interface Impedance:	75Ω
9 pin serial port control interface:	DB9 Female plug x 1
Rs-232 control protocol interface:	5P Phoenix terminal X 1
Rs-422 control protocol interface:	5P Phoenix terminal X 1
Dante interface:	RJ45x1
Audio output:	XLRM x 1, 6.35mm jack x 1, RCA Lotus x 1
Audio input:	RCA Lotus x 1
Screen type:	OLED
Key mode:	Touch style
Dimension (mm):	410 (W)×206 (D)×43 (H)
Weight:	Approximately 2.3kg

Key Features

Practical Function

- Adopt the OLED display, can display the microphone status, operating mode, central controller status, the number of speaker, etc.
- 4 kinds of conference mode selection: FIFO, Automatic(with limiting time), Request, Sound activate.
- The central controller can select the number of speakers, active 2/3/4 microphones in a time.
- Support camera tracking, through the serial port RS-232 or RS-422communication protocol control up to 4 cameras, compatible with VISCA, PELCO-D, PELCO-P 3 kinds of camera control code protocol.
- With 4 video inputs and 1 video output port, SD and HD SDI video inputs and outputs are supported. HD SDI supports HDcctv1.0, HD-SDI (ST292), 3G-SDI (ST424) and SD-SDI (259).
- 9-pin serial port control interface can be connected to intelligent control system for camera tracking.
- The newly developed high-voltage, low-current power supply system minimizes line voltage losses and minimizes the effects of overly long connecting cables. One cable to connect more conference units makes installation easier.
- Adopt using anti shedding aviation cable hand in hand connection mode, the connection is simple, reliable and stable, the whole system required engineering and installation costs can be reduced.

Dante Audio Transmission Protocol

- Support Dante protocol, flexible to meet various engineering solutions.

Flexible Expanding

- It is easy to expand and change configuration. The central controller connect up to 30 microphone units. If connect the EXP-124W, can connect up to 110 microphone units.
- Connecting telephone coupler can be applied directly to a remote call meeting.

Flexible Speaking

- CS-360C chairman unit has the priority to override all delegate units, to control the atmosphere of the meeting.

Four Speech Mode:

- ① Time limiting: The speech time limit can be set to 1-60 minutes, and the speech will be automatically closed when the time is up. After reaching the power-on quantity, when another representative wants to speak, it will automatically enter the request-to-speak registration queue.
- ② FIFO: FIFO mode (default). After reaching the power-on number, the speaking unit that was opened first is closed by the subsequent speaking unit.
- ③ Request: The speaking of the representative unit needs to be approved by the chairman unit or the operator. In this mode, the chairman unit always keeps the normally open state.
- ④ Voice Activated: When the microphone is turned on by voice, manual operation is not required. After the number of power-on is reached, the speaking unit that is turned on first is turned off by the subsequent speaking unit.

Multiple Ports

- With record output can connect the recorder, all records can be fully recorded and saved, also can connect the external audio device.
- With anti drop 9P aviation plug and Cat5 TypeB network port

Clear Sound Quality

- With automatic gain audio processing circuit, prevent feedback effectively and improve the clarity of the whole system.



CS-360C
Chairman unit

CS-360D
Delegate Unit

Polar Pattern:	Super Cardioid Condenser
Frequency Response:	50Hz-18KHz
Sensitivity:	-43dB±-3dB(0dB=1V/Pa,f=1KHz)
SPL:	110dB(THD < 5%, f=1KHz)
S/N (A weighted):	> 60dBA (THD < 1% , f=1 KHz)
Distortion:	< 0.1%
Power Supply:	24V DC(supplied by the receiver)
Maximum Power of Speakers:	0.72W
Weight:	670g
The Length of Microphone:	147(L)×115 (W)×218(H)
Unit Interface:	Wired network port

CS-102

WIRED AUDIO CONFERENCE DISCUSSION SYSTEM



The CS-102 is a simple, affordable discussion audio conferencing system. CS-102M is the control center of the whole system, including conference mode selection, external output sound reinforcement level, line input function, etc. The system can accommodate 256 microphone units, with voice input automatic gain, howling suppression, FIFO and voice-activated functions. Apply to boardrooms, business meetings, educational institutions, hotels, conference rental, system reconstruction, etc.

Product Specification



CS-102M
Central Controller

- EIA Standard Rack 1U metal chassis.
- The speech number could be chosen in the central controller, and has first-in first-out function.
- Equipped with handle, which is easy for lift.

Main Voltage:	AC100-240V 50/60Hz
Maximum Power:	60W
Frequency Response:	65Hz-15KHz
S/N:	>85dB
(T.H.D):	<0.7%
Input:	LINE IN:0dBV (f=1KHz, THD <0.3%) XLR:10dBV 6.3mm -15dBV RCA:0dBV
Output:	Anti-drop 9P aviation plug
Unit interface:	It can be connected to central control system or video tracking system.
RS-232 interface:	
Size(mm):	410(W)×206 (D)×43(H)
Weight(g):	Approximately 2.3Kg



CS-102C
Chairman unit

CS-102D
Delegate Unit

- Refined and elegant design, ergonomic and very modern.
- Comply with IEC60914 international standard.
- the chairman unit equipped with PRIORITY button and can override all the delegate units.
- Super cardioid condenser microphone to achieve high-quality sound pickup.
- Fixed microphone pole.

Main Voltage:	DC24 V
Power Consumption:	0.5 W
Polar Pattern:	Super cardioid
Frequency Response:	80Hz -18KHz
Unit Interface:	Anti-drop 9P aviation plug
Microphone Type:	Super cardioid condenser microphone
Distortion(T.H.D):	<0.7%
Sensitivity:	-30dBv at 1V at 1Pa
Tabletop Size(mm):	105(W)×150 (D)×43(H) (without microphone)
Weight(g):	Approximately 785g

Key Features

Practical Function

- With automatic gain audio processing circuit, it can effectively prevent the feedback and improve the clarity of the entire system.
- Gooseneck conference microphone design, the direction can be adjusted flexibly.
- The indicator on the conference unit shows the speaking status.

Flexible Speech

- Three operating modes: FIFO mode: 1/3/6 in a time, AUTO SPEAKING mode or voice-activated mode.
- CS-102C equipped with PRIORITY button and can override all the delegate units.

Anti-Interference

- It adopts the hand-in-hand connection method of anti-dropping aviation cable, which is simple, reliable and stable.

Flexible Expandability

- With RS-232 interface, it can be connected to central control system or video tracking system.
- The front panel is equipped with a USB interface, which can be connected to a USB flash disk to record the meeting process.
- It can be connected to the conference system expander EXP-124 for further unit expansion.

Application:

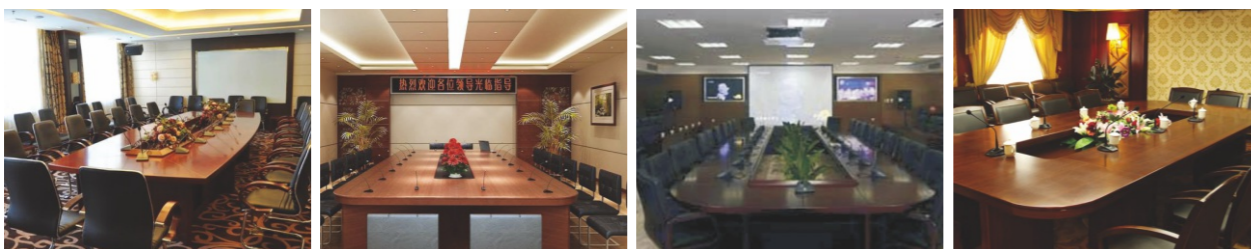

CS-102BC
Flush-mount Chairman Unit

CS-102BD
Flush-mount Delegate Unit

- Refined and elegant design, ergonomic and very modern.
- Comply with IEC60914 international standard.
- The microphone has a bright ring to indicate working status.
- Microphone button with light indicator
- Cardioid condenser microphone to achieve high-quality sound pickup.
- Fixed microphone pole.

Main Voltage:	DC24 V
Power Consumption:	0.5 W
Polar Pattern:	Cardioid
Frequency Response:	65Hz -18KHz
Unit Interface:	Anti-drop 9P aviation plug/Rj45
Microphone Type:	Cardioid Condenser Microphone
Distortion(T.H.D.):	<0.7%
Sensitivity:	-20dBv at 1V at 1Pa
Base Size(mm):	132(W)×90(D)×52(H)
Pole Size(mm):	455(L)
Flush-mount Chairman /Delegate Base Weight:	Approximately 343g
Gooseneck Microphone Weight:	Approximately 343g



CS-501BC
Flush-mount Chairman Unit (with RJ45 connector)

CS-501BD
Flush-mount Delegate Unit (with RJ45 connector)

AI-NC100 | AI NOISE CANCELLATION AUDIO PROCESSOR



Relacart's newly developed AI Noise Cancellation Audio Processor is equipped with a cutting-edge AI algorithm chip. Powered by a high-performance processor, it optimizes audio captured by external microphones, intelligently reducing noise, eliminating reverberation, and dynamically suppressing feedback—delivering an exceptional listening experience. It is ideal for use in conference rooms, classrooms, hotel auditoriums, and business venues.

Key Features

360° AI Noise Reduction

- Removes background noise from both uplink and downlink communications while preserving voice clarity, enabling natural conversations in any setting.

Intelligent De-reverberation

- Utilizes Deep Neural Networks (DNN) to eliminate echoes in reflective spaces (e.g., concert halls), enhancing Direct-to-Reverberant Ratio (DRR) for crystal-clear voice reproduction.

Full-Duplex Acoustic Echo Cancellation

- Eliminates echoes even during simultaneous speech, ideal for low Signal-to-Noise Ratio (SNR) environments without relying on mechanical design.

Dynamic Feedback Suppression

- Integrated AI processor instantly identifies and suppresses narrow band feedback between speakers and microphones, ensuring stable, distortion-free audio.

Product Specification



Frequency response:	20Hz~20KHz
Input gain:	0-45dB (panel adjustable)
Input impedance:	3K Ω
Maximum input level:	17dBu (GAIN at 0dB)
Power supply:	48V phantom power supply (software controlled switch)
Output impedance:	500 Ω
Maximum output level:	17dBu
Power supply mode:	DC 12V/500mA DC power supply
Dimensions (mm):	166 (L) x 83 (W) x 44.6 (H)

AI-NC100

AI Noise Cancellation Audio Processor

System Connection Diagram

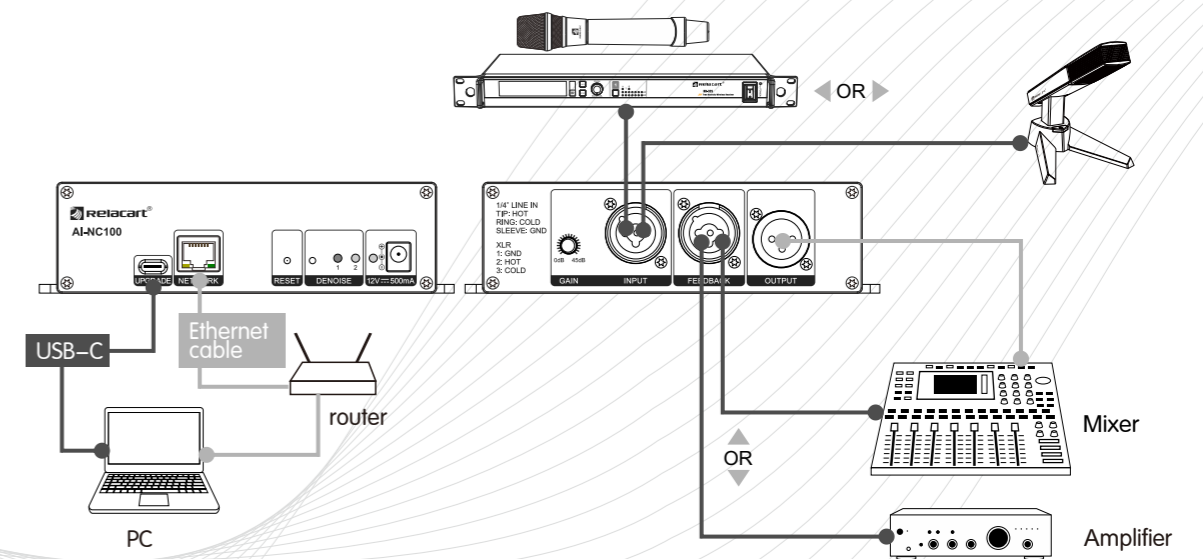

DAM-128D

DIGITAL AUTOMATIC MIXER
WITH DANTE INTERFACE

DAM DIGITAL AUTOMATIC MIXERS
WITH DANTE INTERFACE



12-channel digital auto mixer with automatic opening only the signal input channel, the sound gate action level can be automatically adjusted, this function is only in the microphone when the working state will be activated, can try to avoid multiple open microphone sound quality falling down. Easy to install, just set the session on the spot, that can play an automatic function, do not worry about the setting work. And can be selected according to the needs of automatic processing or forced to close the microphone manual processing function, under the auspices of the host, can make the meeting smoothly. Digital intelligent conference processor is the perfect combination of digital audio and digital control technology to high-performance DSP as the core, with dedicated control software, each channel can be set and adjusted in detail, comes with 12x8 matrix, support multiple levels, All intelligent conference management, can easily form a set of powerful, easy to operate digital intelligent conference system. It is applicable to the high demand of court, business center, conference center, hotel and TV station.

Product Specification

Main Frame Size:	EIA Standard Rack 1U
Dynamic Range (20 Hz to 20 kHz, A-weighted, typical):	Analog-to-Analog : 100dB
Harmonic Distortion 1 kHz, +4 dBu out, mix output (MASTER) at +0 dB:	<0.05%
S/N(22 Hz - 22 kHz, RMS, A-Filter):	118dB
Common Mode Rejection Ratio 150Ω balanced source, at 1kHz:	>60 dB
Number of input channels:	MIC×8, Line×4, Dante×4
Maximum Input Level(Gain Max):	Mic:+6 dBV Line:+25dBV
Maximum Gain:	Mic:+65db Line:+20db
Number of output channels:	Analog×4, Dante×4
Maximum Output Level:	Line(+0):+21dbu MIC(-20):+1dbu
Dante Interface:	4×4
AD/DA Converter:	24bit, 48KHz
Internal Processing:	40-bit, floating point DSP
DSP Functions:	Input, output equalization, limiter, FBK, matrix control, threshold control, high and low pass filter
FRQ Range:	20Hz-20KHz
Phantom Power:	+48V/12mA
Network Interface:	10/100 Mbps Ethernet, Dante digital audio
Dimensions(mm):	410(W)×206(D)×43(H)
Weight:	Approximately 2.7 kg
Operating Temperature Range:	0 ~40°C



DAM-128D

Digital Automatic Mixer
with Dante Interface

- EIA standard 1U metal chassis, professional and elegant.
- Equipped with handle, easy to lift or move.

Computer control the software interface instruction

software interface: (as shown in Fig)

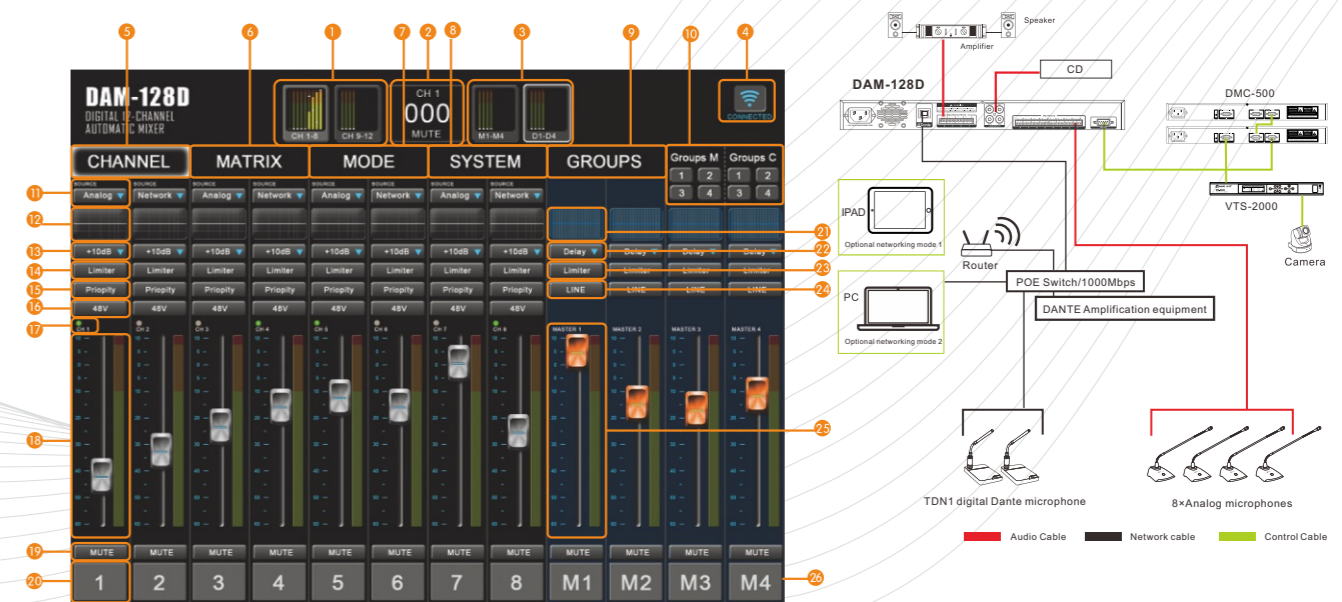

- | | |
|--|--|
| 1. Input Channel Interface Switcher | 14. Input Channel Compressor Setting Interface |
| 2. Parameter Display (can input the current function parameter manually) | 15. Input Channel Priority Function Switch |
| 3. Output Channel Interface Switcher | 16. Input Channel 48V Phantom Power Switch |
| 4. Communication Connection Button and Status Display | 17. Input Channel Working Status Display |
| 5. Channel Page | 18. Input Channel Volume Fader and Volume Display |
| 6. Matrix Setting Page | 19. Input Channel Mute Switch |
| 7. Mixing Mode Setting Page | 20. Input Channel Name Display |
| 8. System Setting Page | 21. Output Channel 31-band Graphic EQ page |
| 9. Group Setting Page | 22. Output Channel Delay Setting Button |
| 10. Mute, Control, Group Function Switch | 23. Output Channel Compressor Setting Page |
| 11. Input Source Switch Menu | 24. LINE Output Channel and Mic Output Switch |
| 12. Input Channel 4-band Parametric EQ Setting Page | 25. Output Channel Volume Fader and Volume Display |
| 13. Input Channel Gain Setting | 26. Channel Name (can edit output channel name) |

Key Features

Powerful Function

- Through the use of TCP / IP connection to achieve computer PC software control and iPad software remote control settings of the parameters: Each channel can be set to priority, limiter adjustment;
- 4 - band parametric equalizer, frequency, Q value, amplitude adjustable;
- Shed filter set, to eliminate unnecessary noise in the band;
- Multi-stage frequency adjustable slope of the high and low pass filter, can show a better transient response;
- Support 8 microphone input channel with 48V phantom power supply independently, 4 MASTER analog output, 4 Dante audio or Dante microphone flexibly-switched input channel.

Intelligent Management

- Using TCP / IP connection, can be connected to special software to achieve the remote control of the conference system, remote diagnosis and upgrade.

Flexible Expansion

- Built-in Ethernet version of the DANTE™ digital audio card, can connect the mixer to any DANTE™ device
- The RS-232 interface can be used to connect central control equipment and camera tracking system.

Independent Channel Digital Process

- With 12 independent working channels, each channel output can be independently adjusted gain, do not interfere with each other, multi-functional intelligent meeting digital auto mixer.
- Independent configuration FBK, NOMA function
- All-digital signal processing, built-in high, low-pass filter, limiter, 12*8 matrix and so on. The basic use of the operation connected to the computer with proprietary control software, each channel can be detailed settings and adjustments.
- 12-channel input and 8-channel output with DANTE, analog and digital mixing matrix control, suitable for a wider range of application.

Application:



DAM-208D | DIGITAL AUTOMATIC MIXER WITH DANTE INTERFACE



DAM-208D is a 20-input, 8-output, intelligent digital mixer that supports Dante protocol. Digital intelligent conference processor is the perfect combination of digital audio and digital control technology to high-performance DSP as the core, with dedicated control software, each channel can be set and adjusted in detail, comes with 20X8 matrix, support multiple levels, All intelligent conference management, can easily form a set of powerful, easy to operate digital intelligent conference system. It is applicable to the high demand of court, business center, conference center, hotel and TV station.

Product Specification

Main Frame Size:	EIA Standard Rack 1U
Dynamic Range (20 Hz to 20 kHz, A-weighted, typical):	Analog-to-Analog : 100dB
Harmonic Distortion 1 kHz, +4 dBu out, mix output (MASTER) at +0 dB:	<0.05%
S/N(22 Hz - 22 kHz, RMS, A-Filter):	118dB
Common Mode Rejection Ratio 150Ω balanced source, at 1kHz:	>60 dB
Number of input channels:	MIC×16, Line×4, Dante×4
Maximum Input Level(Gain Max):	Mic:+6 dBV Line:+25dBV
Maximum Gain:	Mic:+65db Line:+20db
Number of output channels:	Analog×4, Dante×4
Maximum Output Level:	Line(+0):+21dbu MIC(-20):+1dbu
Dante Interface:	4×4
AD/DA Converter:	24bit, 48KHz
Internal Processing:	40-bit, floating point DSP
DSP Functions:	Input, output equalization, limiter, FBK, matrix control, threshold control, high and low pass filter
FRQ Range:	20Hz-20KHz
Phantom Power:	+48V/12mA
Network Interface:	10/100 Mbps Ethernet, Dante digital audio
Dimensions(mm):	410(W)×206(D)×43(H)
Weight:	Approximately 2.7 kg
Operating Temperature Range:	0~40°C

DAM-208D

Digital Automatic Mixer with Dante Interface

- EIA standard 1U metal chassis, professional and elegant.
- Equipped with handle, easy to lift or move.

Computer control the software interface instruction

software interface: (as shown in Fig)

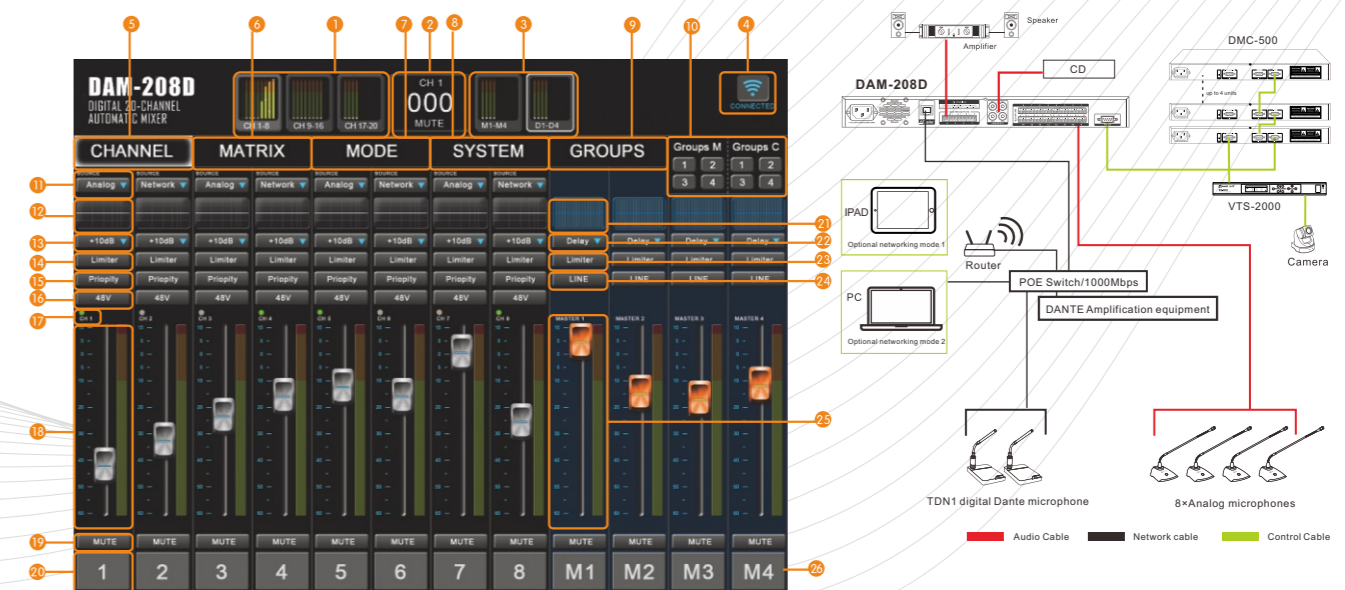

1. Input Channel Interface Switcher	14. Input Channel Compressor Setting Interface
2. Parameter Display (can input the current function parameter manually)	15. Input Channel Priority Function Switch
3. Output Channel Interface Switcher	16. Input Channel 48V Phantom Power Switch
4. Communication Connection Button and Status Display	17. Input Channel Working Status Display
5. Channel Page	18. Input Channel Volume Fader and Volume Display
6. Matrix Setting Page	19. Input Channel Mute Switch
7. Mixing Mode Setting Page	20. Input Channel Name Display
8. System Setting Page	21. Output Channel 31-band Graphic EQ page
9. Group Setting Page	22. Output Channel Delay Setting Button
10. Mute, Control, Group Function Switch	23. Output Channel Compressor Setting Page
11. Input Source Switch Menu	24. LINE Output Channel and Mic Output Switch
12. Input Channel 4-band Parametric EQ Setting Page	25. Output Channel Volume Fader and Volume Display
13. Input Channel Gain Setting	26. Channel Name (can edit output channel name)

Key Features

Powerful Function

- Through the use of TCP / IP connection to achieve computer PC software control and iPad software remote control settings of the parameters
- Each channel can be set to priority, limiter adjustment
- 4-band parametric equalizer, frequency, Q value, amplitude adjustable
- Shed filter set, to eliminate unnecessary noise in the band
- Multi-stage frequency adjustable slope of the high and low pass filter, can show a better transient response

Flexible Expansion

- Built-in Ethernet version of the Dante™ digital audio card, can connect the mixer to any Dante™ device
- The RS-232 interface can be used to connect central control equipment and camera tracking system.
- Connect multiple DMC-500 mixer controllers without software control to adjust common channel volume

Intelligent Management

- Using TCP / IP connection, can be connected to special software to achieve the remote control of the conference system, remote diagnosis and upgrade

Independent Channel Digital Process

- With 20 independent input working channels, each channel can adjust the input gain separately, and support Dante input channel conversion; Dante output, do not affect each other.
- High-speed DSP chip with 40 bit floating-point operation and working frequency > 450MHz, combined with the digital audio automatic mixing algorithm independently developed by Relacart core technology team, always maintains the style of displaying the most realistic sound; and supports Dante microphone mixing features
- All-digital signal processing, built-in high, low-pass filter, limiter, 20*8 matrix and so on. The basic use of the operation connected to the computer with proprietary control software, each channel can be detailed settings and adjustments.
- Automatic threshold adjustment, which can calculate the most suitable valve level based on the ambient noise of the scene using the powerful computing system of DSP digital algorithm, suitable for any bad meeting environment. With hold time function to ensure your meeting is smoother.
- 20-channel input and 4-channel output with DANTE, analog and digital mixing matrix control, suitable for a wider range of application.

Application:





CONFER X is a digital automatic mixer with 64-channel input and 16-channel output, which is independently developed by Relacart and the global-first creation. 64-channel input, 16-channel output analog and DANTE digital hybrid matrix control are suitable for wider application engineering. 1-32 automatic mixing channels can set each channel independently and open threshold. It can set the most suitable threshold level according to the environmental noise, echo and the channel near the loudspeaker. It is suitable for any harsh meeting environment. And the hold-time is adjustable, ensure that your meeting is smoother.

Product Specification

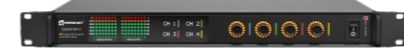

CONFER X

Digital 64-channel Automatic Mixer with Dante Interface

- EIA standard 1U metal chassis, professional and elegant.
- Equipped with handle, easy to lift or move.

Main Frame Size:	EIA Standard Rack 1U
Dynamic Range (20 Hz to 20 kHz, A-weighted, typical):	Analog-to-Analog : 100dB
Harmonic Distortion 1 kHz, +4 dBu out, mix output (MASTER) at +0 dB:	<0.05%
S/N(22 Hz - 22 kHz, RMS, A-Filter):	118dB
Common Mode Rejection Ratio 150Ω balanced source, at 1kHz:	>60 dB
Number of input channels:	MIC×4, Dante×64
Maximum Input Level(Gain Max):	Channel input AUX Input (Lotus): +25dBu
Number of output channels:	Analog×8, Dante×8
Maximum Output Level:	Line(+0):+21dbu MIC(-20):+1dbu
Dante Interface:	64 (input)× 8(output)
AD/DA Converter:	24bit, 48KHz
Internal Processing:	40-bit, floating point DSP
DSP Functions:	Input, output equalization, limiter, FBK, matrix control, threshold control, high and low pass filter
FRQ Range:	20Hz-20KHz
Power Requirements:	~110V-240V 50/60Hz 60W
Network Interface:	10/100 Mbps Ethernet, Dante digital audio
Dimensions(mm):	410(W)×206(D)×43(H)
Weight:	Approximately 2.7 kg
Operating Temperature Range:	0 ~40°C

Computer control the software interface instruction software interface: (as shown in Fig)

Key Features

Intelligent Management

- The main controller adopts TCP/IP connection mode and can connect special software to realize remote control of conference system, remote diagnosis and upgrade.

Practical function

- Through TCP/IP connection, can set every parameter by the computer software and the remote setting of the iPad software.
- Priority and compressor adjustment can be set for each channel.
- Four-segment parametric equalization, adjustable frequency, Q value and amplitude;
- The filter can eliminate unnecessary noise in the frequency band.
- High-pass and low-pass filters with adjustable frequency can exhibit better transient response.
- Encoders with scaling indicators can control the volume of four channels, and can set any input/output channel to display volume scale, mute indication, distortion indication and output LINE/MIC indication respectively. Each encoder is equipped with an OLED display screen to display channel name and channel volume value.

Dante Flexible Expansion

- Built-in Dante digital audio card can connect the mixer to any Dante device.
- RS-232 interface can connect to central control and video tracking system.
- Without the use of software control, multiple DMC-500 mixer controllers can be connected to adjust the commonly used channel volume.

Independent Channel Digital Process

- 64-Channel Dante input, channel1-32 adopt DSP algorithm auto mix, channel33-64 support analog input conversion.
- 16-channel independent output, 8 channel is analog signal output, 8 channel is Dante signal output
- 4 channel is line input(RCA plug), can be switched arbitrarily in 33-64 channels and can not be set repeatedly.
- Full digital signal processing, built-in high-pass and low-pass filters, limiters, matrix, etc. The basic operation is connected to the computer with special control software, which can make detailed settings and adjustments for each channel.
- 64 x 64 Dante and analog mixing matrix control, suitable for wider application engineering.

Application:

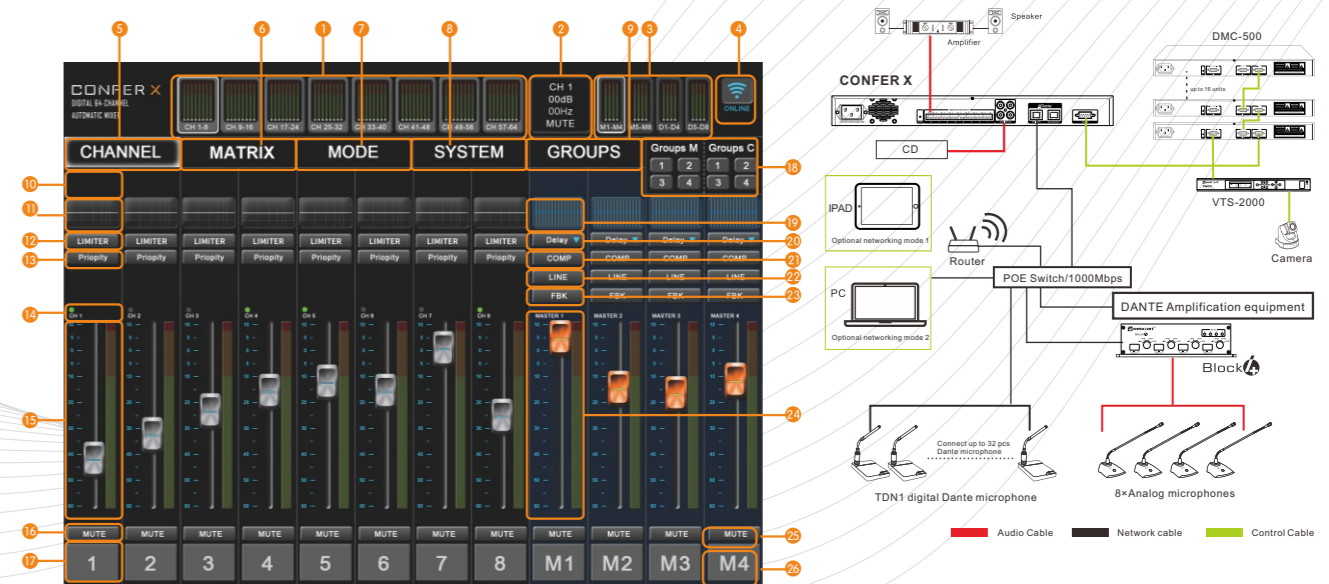

1. Input Channel Interface Switcher	14. Input Channel Working Status Display
2. Parameter Display (can input the current function parameter manually)	15. Input Channel Volume Fader and Volume Display
3. Output Channel Interface Switcher	16. Input Channel Mute Switch
4. Communication Connection Button and Status Display	17. Input Channel Name Display
5. Channel Page	18. Mute and Control Group Function Switch
6. Matrix Setting Page	19. Output Channel 15-band Graphic EQ page
7. Mixing Mode Setting Page	20. Output Channel Delay Setting Button
8. System Setting Page	21. Output Channel Compressor Setting Page
9. Group (Mute Group and Control Group Setting)	22. LINE Output Channel and Mic Output Switch
10. Input Source Switch Menu (For channel 33-64 only)	23. FBK (can avoid feedback automatically)
11. EQ Setting (For channel 1-32 only)	24. Output Channel Volume Fader
12. Input Channel Compressor Setting Interface	25. Output Channel Mute Switch
13. Input Channel Priority Function Switch	26. Channel Name (can edit output channel name)

DAM-124

12-CHANNEL DIGITAL
AUTOMATIC MIXER



DAM-124 12-channel digital mixer is a combination of digital audio and digital control technology. It takes high-performance DSP as the core and works with special control software to make detailed settings and adjustments for each channel. It comes with a 12x4 matrix, full intelligent conference management, easy to operate.

Product Specification



DAM-124

12 Channel Wired Digital Automatic Mixer

Main Frame Size:	EIA Standard Rack 1U
Dynamic Range:	100dB
THD+N Distortion:	<0.05%
S/N Ratio:	118dB
Common Mode Rejection Ratio:	>60 dB
Number Of Input Channels:	MIC×8, Line×4
Maximum Input Level:	+6 dBu
Line Input (RCA):	+25dBu
Total Amplification Gain:	Mic:+65db Line:+20
Number Of Output Channels:	Analog×4
Maximum Output Level:	Line (+0):+21dbu MIC (-20):+1dbu
AD/DA Converter:	24bit, 48KHz
Internal Processing:	40-bit, floating point DSP
DSP Functions:	Input, output equalization, limiter, FBK, matrix control, threshold control, high and low pass filter
Power Requirements:	~110V-240V 50/60Hz 60W
Audio Frequency Response:	20Hz-20KHz
Phantom Power Supply:	+48V/12mA
Network Interface:	10/100 Mbps Ethernet
Dimensions(mm):	410(W)×206(D)×43(H)
Weight:	Approximately 2.7 kg
Operating Temperature Range:	0 ~40°C

Computer control the software interface instruction software interface: (as shown in Fig)

Key Features

Powerful Function

- Standard 1U all metal case, aluminum panel; Clear and bright LED lights on the front panel display the input and output audio dynamic information at all times; Encoder with scale indication.
- Support the grouping setting of mute and other control parameters; The conference scene mode is saved to provide a very convenient debugging method for similar venues.
- 48V phantom power supply is attached to the 8 mic input channel; 4-channel line input; Independent mute control and phantom power control; Priority selection and threshold adjustment can be set for each channel.
- It supports automatic adjust the attenuation value of multi-channel microphone(NOM), and the maximum number of open microphones supports 1~8.

DSP Automatic Sound Gate Regulation

- The automatic sound gate adjustment can automatically calculate the appropriate gate level by using the powerful computing system of DSP digital algorithm according to the on-site environmental noise, which is suitable for any harsh conference environment;
- The LAST HOLD TIME function can make the conference more orderly.

Independent Channel Digital Process

- It has 12 independent input working channels, and each channel can adjust the input gain independently.

Application:

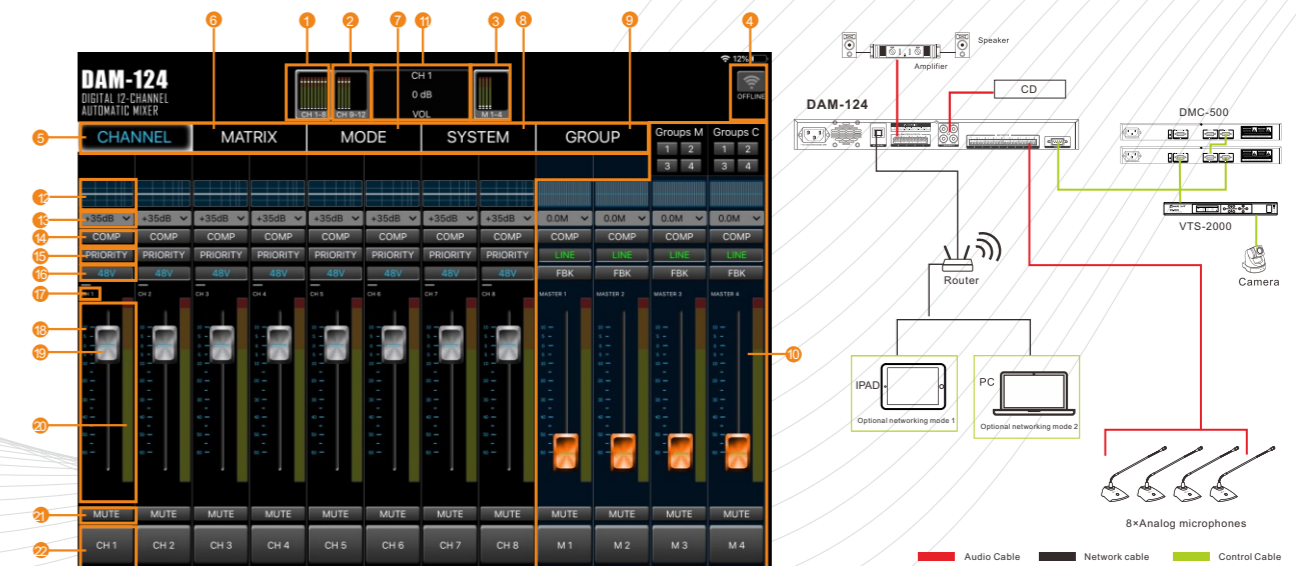

- Input channel 1-8 window: channel 1-8 of the pusher status display and input level display. Click on the page can switch to the input channel.
- Input channel 9-12 window: display channel 9-12 state of pusher and input level display. Click on the page can switch to the input channel.
- Output Channel Interface Switcher
- Communication Connection Button and Status Display
- Channel Page
- Matrix Setting Page
- Mixing Mode Setting Page
- Save system: communications equipment, scene, firmware upgrade, restore the factory Settings, etc.
- Grouping: mute group and control group Settings.
- The main output channels: can control the function of the main output channel.
- Function status display window: three rows, according to the first line of the current channel is set, the second line current setting the parameters of the function, the third line of the function of the current Settings.
- Input channel EQ: adjust the defects of compensation speakers and ShengYang, compensation and modify various input source.
- Input Channel Gain Setting
- Input Channel Setting Page
- Input Channel Priority Function Switch
- Input Channel 48V Phantom Power Switch
- Input Channel Working Status Display
- Input Channel Volume Fader
- Volume Display
- Input Channel Mute Switch
- Input Channel Name Display



VTS-2000 Video tracking system can be used with any one Relacart video conferencing system to achieve video tracking function. When the microphone unit is on, the camera will automatically track the location of the speakers unit. Connect the video device can display the image. Unique freeze function, can achieve the camera auto tracking feature perfectly.

Key Features

Powerful Function

- Do not need any additional equipment, through the central main controller menus can set camera tracking directly.
- Simultaneous control up to four cameras.
- Always follow the last opened speaking unit.
- When one single microphone unit is turned off that can automatically tracking previous speaking unit.
- All the microphone is turned off, automatically return to the default panorama
- Sharing agreement, the camera is compatible with all common types of reality.
- With 4 video input and 1 video output port, support SD and HD SDI video input and output, HD SDI supports HDcctv1.0, HD-SDI(ST292), 3G-SDI(ST424), SD-SDI(259) standard.
- HD SDI can support the highest resolution 1080P @ 60Hz

Product Specification



VTS-2000
Video Tracking System

Main Frame Size:	EIA Standard Rack 1U
Power Supply:	AC 100~240V 50/60Hz
Frequency Response:	143Mb/s to 2.97Gb/s
Gain:	0dB
Signal Type:	SDI (high-definition digital signal)HDcctv1.0, HD-SDI(ST292), 3G-SDI(ST424), SD-SDI(259)
Input Return Loss:	21dB @ 5MHZ-3GHz
Video Input:	800mVp-p
Video Output:	800mVp-p
Compatible Standard:	Pelco-D、Pelco-P、Visca
Control Protocol:	RS-232, RS-422, RS-485
Baud Rate:	9600
Data Bits:	8bitsVideo
Input/Output Impedance:	75 ohm
Input and Output Ports:	BNC
Dimensions(mm):	410(W)×43(H)×206(D)
Weight(kg):	About 2.3

System Connection Diagram

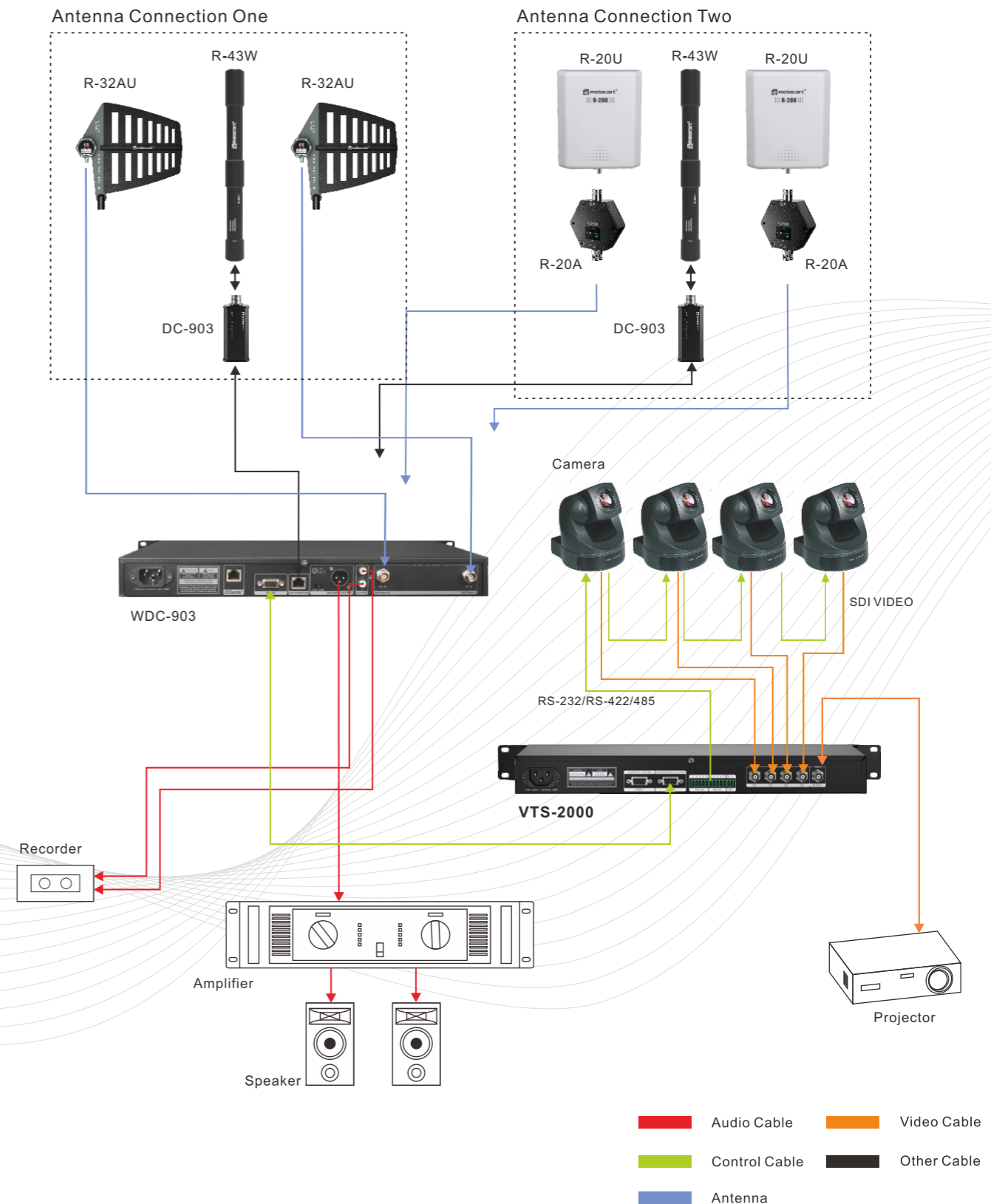



Relacart TGS-6 Wireless Tour Guide Microphone System adopts UHF high-fidelity audio transmission technology to ensure stable use in various indoor and outdoor environments, and output high-quality sound, DSP digital audio companding processing can greatly reduce the noise of the wireless transmission. The innovative magnetic suction and soft rubber design is convenient for users to use, and can be attached to the collar, freeing hands to speak easily. The transmitter has a built-in omnidirectional condenser microphone and also supports external microphones with a 3.5mm jack. The receiver supports TS jack headphone output. The guide wears the transmitter, and tourists can move freely within a 20-meter range. This wireless tour guide system allows visitors to stay connected to the guide's commentary while exploring freely. This system is ideal for tourism guide, factory tours, church activities, school meetings and more.

Key Features

UHF UHF Audio Transmission Technology

- Works in the UHF frequency band, avoiding WiFi with serious interference, ensuring the stability of the wireless connection and providing high-fidelity audio output

DSP DSP Digital Audio Companding

- 48KHz audio sampling rate to minimize noise in the system wireless connection and providing high-fidelity audio output

External Microphone Expansion

- In addition to the built-in microphone, the external microphone and line input function can also be used, and the receiver and transmitter can independently adjust the volume audio output

LED Multi-Channel Switching

- Both transmitter and receiver support one-key channel switching and display in the LED digital display

Magnetic Rubber Clip

- The innovative design of magnetic suction and soft glue, including a hot shoe magnet specially designed for the camera, makes the product easy to use, close to the collar during interviews or close to objects with iron, nickel and other metals, such as mobile phones, computers, etc., the novel design of magnetic rubber improves the flexibility of users in product application

Lightweight and Convenient

- The net weight of the TGS-6 transmitter and receiver is 31.5g each. Compact design, easy to carry

Anti-Noise

- The product comes with a special microphone windproof furry to ensure clear sound pickup in outdoor or noisy environments

Product Specification



TGS-6R
Wireless Receiver

Receiving Bandwidth :	521.25MHz-936.85MHz
Receiving Method :	Superheterodyne
Image Rejection :	45dBm
RF Sensitivity :	When inputting 10dBu, S/N ≥ 45dB
SQ Adjustment :	Built-in setting parameters
Frequency Synchronization Method :	Manual key setting
Maximum Output level (analog) :	0.7Vpp
Output level adjustment range :	3-level adjustable, attenuated adjustment, every 3dB step
Audio Output:	3.5MM TS Jack
Power Supply Mode :	Built-in 3.7V 450mA lithium battery power supply
Normal Working Current :	100mA
Battery Life :	≥ 4 hours when the battery is fully charged
Dimensions(mm) :	67(H) × 32(W) × 13.5(D)
Net Weight :	31.5g



EP-01
Headphone

Dimension :	(Φ)22.8×6.2mm
Power Rate:	Rated1/Max.1.5MW
Impedance:	32Ω±15%, at1kHz1.0V
Out S.P.L.:	103dB±3(1MW/0.25M), At1.0K,1.2K, 1.5K, 2.0KHz(Average figures)
Frequency Rang:	Fo~15KHz, Output S.P.L.±10dB
Operation Temp :	-20~+55°C
Resonance Frequency:	380±20%Hz, At 1.0V
Distortion :	10% Max,At1.0KHZ,0.1W



TGS-6T
Wireless Transmitter

Carrier Bandwidth :	521.25MHz-936.85MHz
Oscillation Mode :	PLL frequency synthesis
Transmit Power :	13.5dBm
Carrier Deviation :	0.005%
Harmonic Radiation :	-32dBm
Modulation Method :	FM
Nominal/Max. Deviation Range :	± 65KHz
Maximum Input level :	250mV
Input gain Adjustment :	3 levels adjustable
Input Impedance :	2.2KΩ
Frequency Setting :	manual button to set frequency
Power Supply Mode :	built-in lithium battery or TYPE-C 5V power supply
Normal Working Current :	100mA
Battery Life :	≥ 4 hours when the battery is fully charged
Dimensions(mm) :	67(H) × 32(W) × 13.5(D)
Net Weight :	31.5g

RT-C45
Charging Case



Input voltage:	100-240VAC, 50/60Hz
Max. power consumption at full load:	100W
Charging voltage/current (single compartment):	5V/0.4A
Power consumption (single compartment):	2W
Charging slots:	45
Charging time:	<2.5 hours
Charging environment temperature:	-20°C-40°C
Dimensions (WxHxD):	540 × 146 × 400 mm
Weight:	Approximately: 5.265kg

BLOCK 4+

DANTE NETWORKED AUDIO INTERFACE

BLOCK 4+ DANTE NETWORKED AUDIO INTERFACE



Block4+ is a Dante-enabled digital audio switch combining 4 input and 4 output. Dante is a network protocol, which bases on the three-layer IP network technology, provides a low latency, high precision and low cost solution for point-to-point audio connection. Dante technology can apply to transmitting high precision clock signal and audio signal and can perform complex routing in Ethernet(100M or 1000M), to ensure a perfect sound effect; to solve the problem of complicated wiring of traditional audio transmission, reduce the cost. Adapt to the existing network, do not need to do special configuration. Block 4+ can be used with routers without PoE and with PoE power supply. When connecting to ordinary routers without PoE power supply, Block 4+ requires an external power supply.

System Connection Diagram

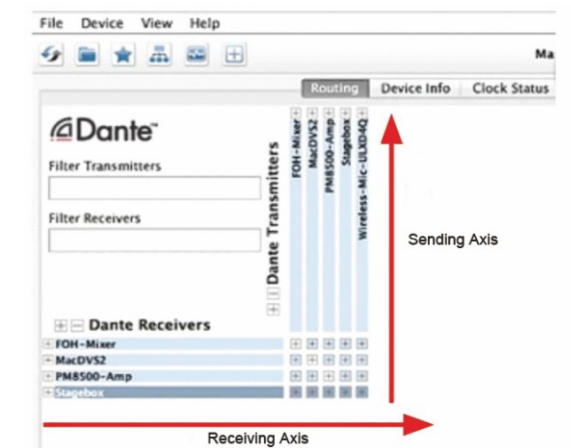
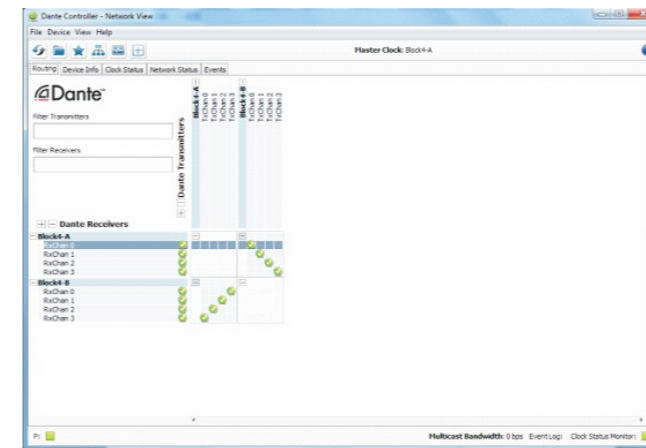

We need a Dante-enabled mixer, wireless microphone and power amplifier. All the equipment need to connect to the current switch board, all the Dante devices set to default. The connection is not complicated and no need professional knowledge, before connecting to the network switch board, just use the common CAT5 or CAT6 network cable to connect the primary port of Dante devices, then connect to any port of the 100M or 1000M switch board, (Remark: Dante can not run in WiFi environment, wired it relies on the stable network environment to transmit perfect audio)

Key Features

Flexible Configuration

- Connect directly to network via Ethernet cable-no need for expensive audio cable or soldering
- Powered by network PoE: PoE IEEE802.3af standard
- Easy operation, simple mechanical gain adjustment switch, clear working indicator
- 48V phantom power

Flexible Expansion

- 4-channel analog audio output, equip with four indicator
- Equip with network connection indicator, network audio indicator, power indicator, reset switch
- RF anti-interference design.
- Solid alloy structure.

Product Specification



Weight:	0.5KG
Audio Interface:	Standard 3.81mm pitch plug type connection terminal
Audio Frequency	
Response:	20Hz~20KHz +2dB
Dynamic Range:	98dB, Analog to Analog
Input channel gain:	Nominal : LINE / AUX / +15dB / +30dB Gear level : -10dBV / 0dBV / +15dBV / +30dBV Max input : +16dBV / +7dBV / -8dBV / -22dBV 48V status : OFF / OFF / ON / ON
Input impedance:	2.2kΩ
Output impedance:	600Ω
Output level:	+16dBV MAX
Output channel:	AUX: +10dBV
Power consumption:	4W
DANTE Network:	RJ45 connector, CAT5E or CAT6 cable over 100 Mbps
Dimension(mm) :	166(W) × 83(D) × 44.6(H)
Power supply :	PoE IEEE802.3af standard, DC 12V/1A DC power supply

BLOCK 4+

Dante Networked Audio Interface

LevelA connection diagram

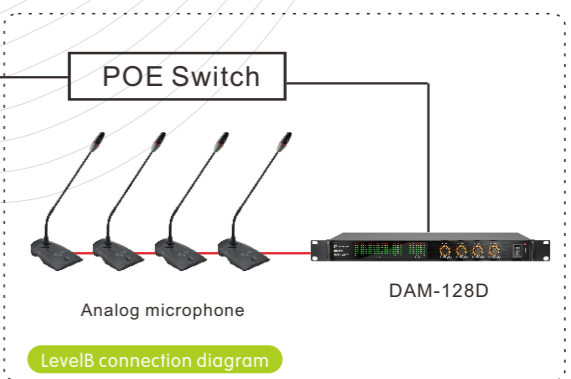
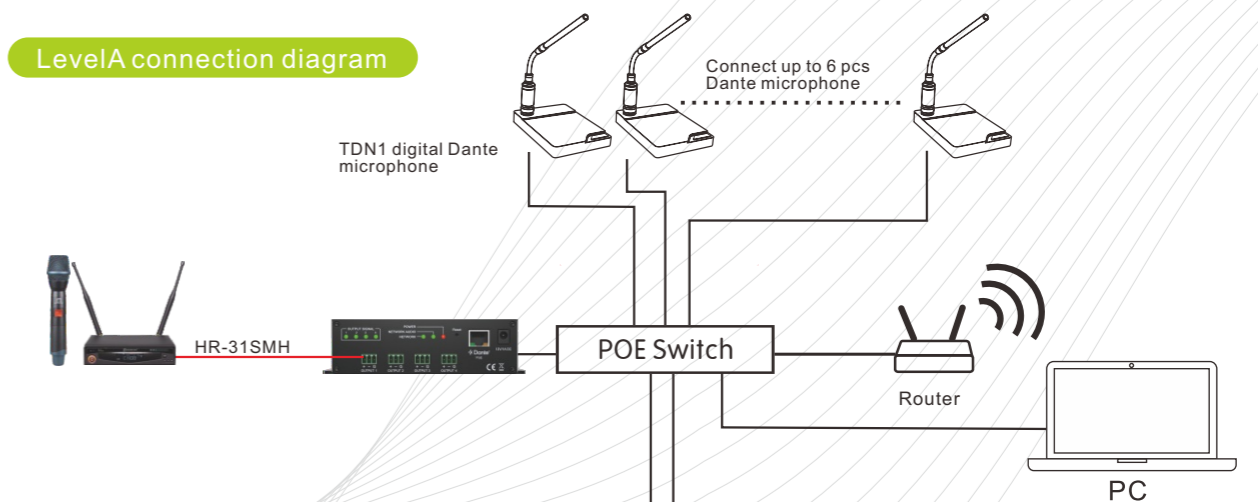

(Multi-level audio transmission application)

Audio Cable
Other Cable

MAS-D | MICROPHONE ARRAY SYSTEM

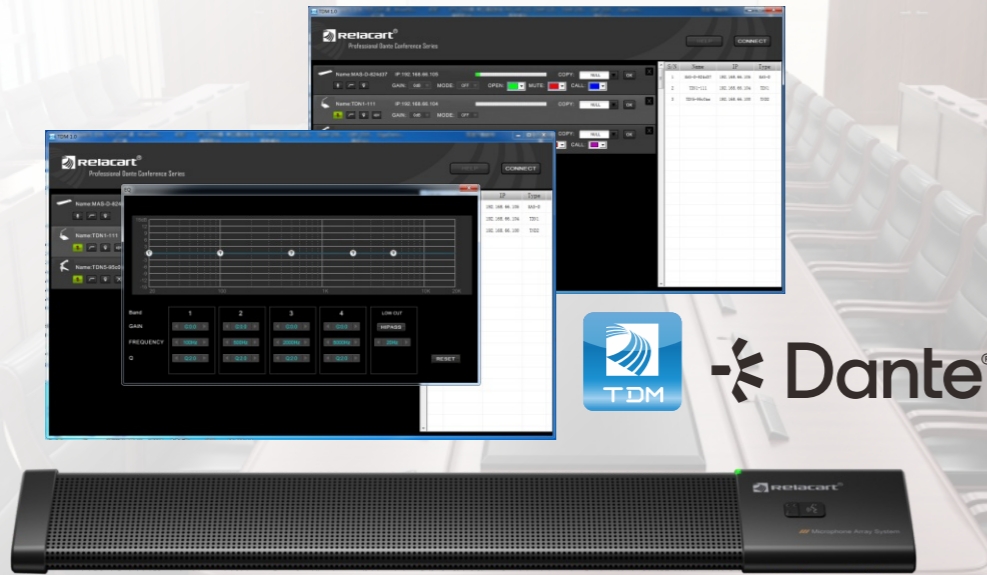

The MAS-D array microphone adopts a metal streamlined desktop design, which is stylish and succinct. It also has a unique microphone array technology and an integrated microphone module, which improves the range and quality of the array microphone. It ensures that the spokesman does not affect the sound effect within a certain range. Dispense microphone stem and the larger pickup range gives the spokesman more space to use.

Key Features

- The array microphone provides a silent electronic switch that controls the microphone's radio operation and work indicator. When the red light is on, the microphone is muted, and when the green light is on, the microphone is in the radio state.
- It adopts PoE power supply and Dante protocol, and professional RJ45 connection. Only one network cable is connected to the switch with PoE power supply. It can be combined with other Dante devices to form the system output sound. It is easy to install and is ideal for various conferences, lectures and recordings.
- Thanks to the unique microphone module circuit design, the array microphone has a pickup distance of 80CM and a deeper pickup range, and the pointing characteristics are significantly improved compared with the general cardioid microphone.
- MAS-D array microphones feature radio frequency interference (RF) shielding technology that provides outstanding protection against radio frequency interference and avoids interference such as mobile phones when receiving radio.

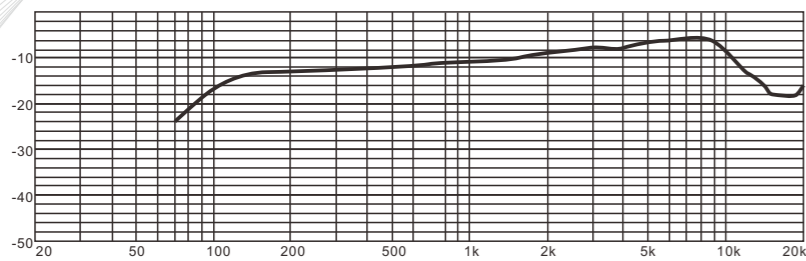

Frequency Response

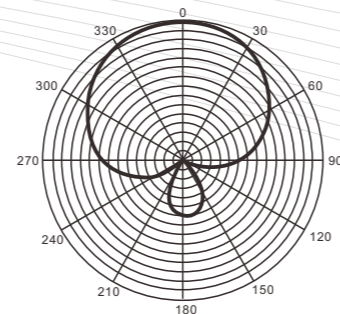

Polar Pattern

Product Specification



MAS-D
Microphone Array System

Frequency Response:	20-20000Hz
Input Impedance:	2.2KΩ
Sensitivity:	-11dB at 1KHz@1Pa
S/N Ratio:	65dB at 1KHz
SPL:	-14dBA at 1KHz@1Pa
Pickup Distance:	80CM
Port:	RJ45
Power Supply Mode:	PoE IEEE802.3
Power Consumption:	2.3W
Weight:	350g
Dimensions(mm):	320(W)×60(D)× 31(H)
DANTE Network:	RJ45 connector, CAT5 or CAT6 network above 100Mbps

System Connection Diagram

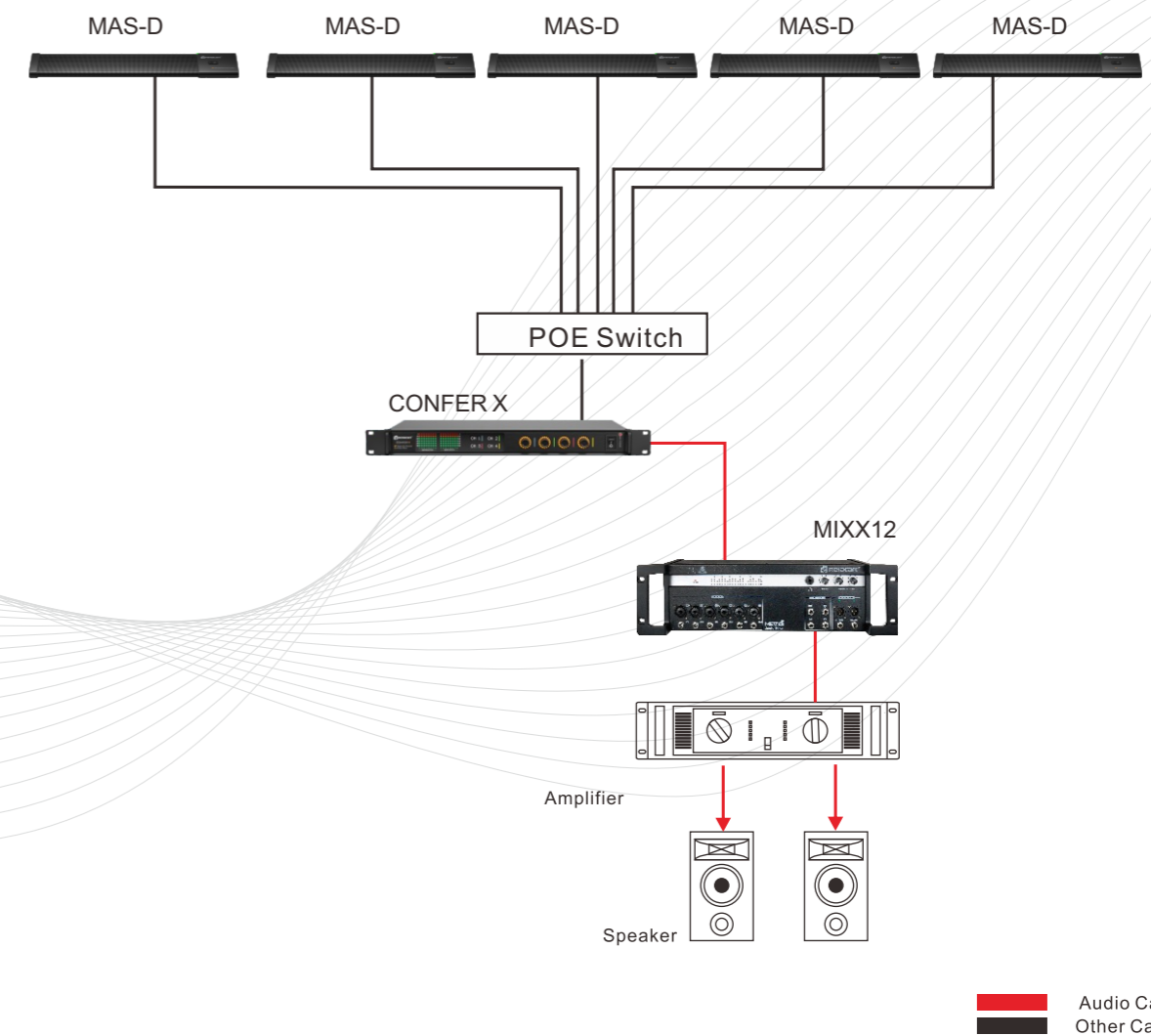

TDN3

DESK MICROPHONE WITH DANTE NETWORK OUTPUT



TDN3 is a wide-bandwidth condenser super-directional DANTE microphone with high-quality pickup performance. It is designed for enhanced pickup, professional recording, television broadcasting, conferences and other demanding pickup applications.

Product Specification

Frequency Response:	20Hz-20KHz
Gain :	6 levels of gain adjustable
Bass Cut:	150Hz, 18dB/Octave
S/N:	65dB, 1KHz at 1Pa
Power Supply Method:	POE IEEE802.3af
Output Interface:	Standard Ethernet interface
DANTE Network:	RJ45 connector, 100Mbps or above, CAT5 or CAT6 or above
Indicator Light:	LED multi-color adjustable status indicator light
Equalizer:	4-band parametric equalizer, set through TDM software
Power Consumption:	2.3W
Overall Size (mm):	148(L)×115(W)×233(H)
Weight:	Approximately 715g



TDN3

Professional Desk Microphone

System Connection Diagram

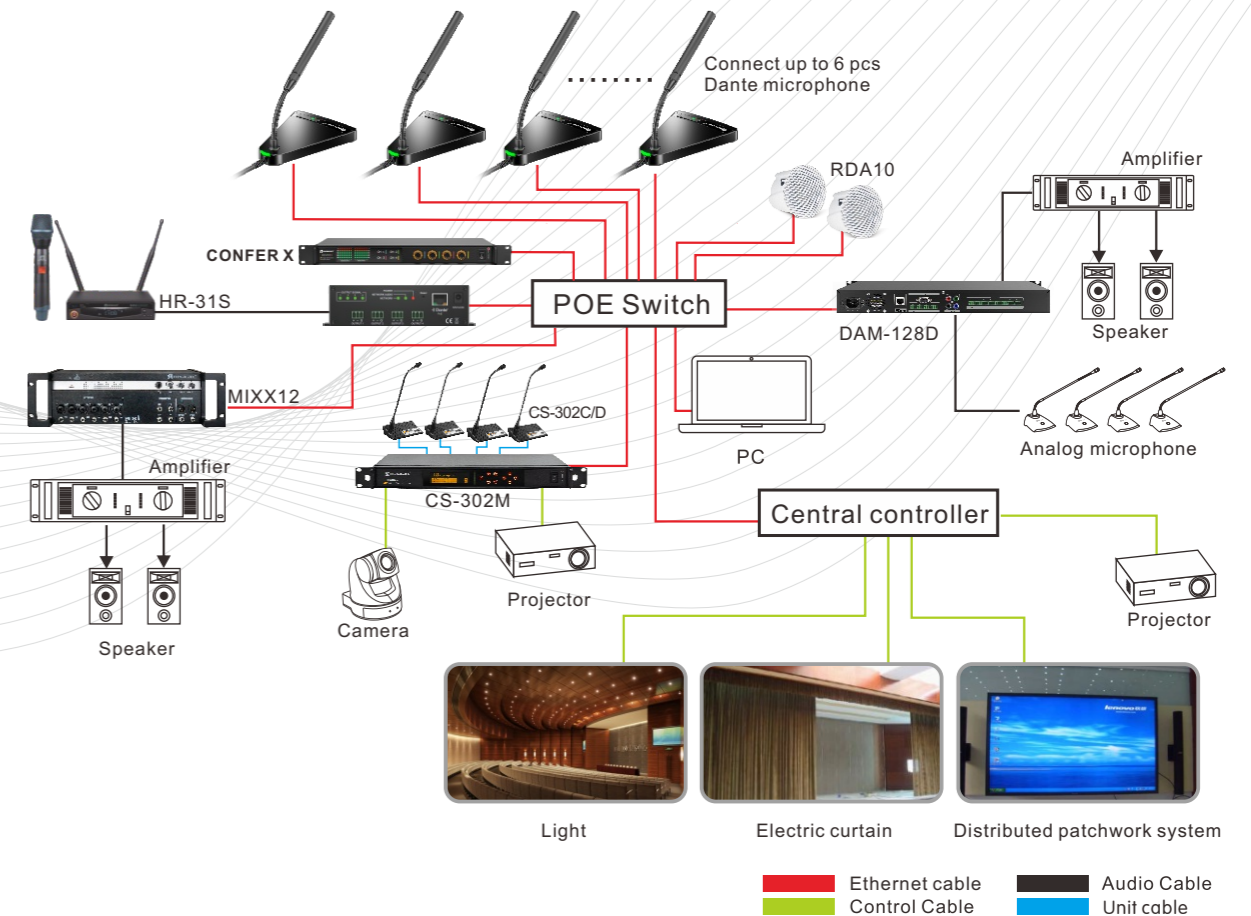

Key Features

- Dante Audio Transmission Protocol**
 - With Dante interface, it can communicate with any device with Dante to transmit audio.
- TDM Digital Control Software**
 - Supports TDM digital control software to allow the microphone to visualize the IP address and customize the microphone's treble and bass, frequency, light color and volume. The above settings can be used to directly copy the preset project parameters to the current microphone through the software when using multiple microphones.
- RJ45 standard network cable interface**
 - Equipped with standard RJ45 standard network cable interface.
- Light - touch switch troubleshooting**
 - It is equipped with a unique light - touch switch troubleshooting function. After pressing the button, the LED will flash and the location of the faulty microphone can be quickly found, which greatly reduces the difficulty of subsequent maintenance work.
- Appearance material**
 - The microphone adopts a small triangular shape gooseneck design, which has a simple and elegant appearance, and can easily and flexibly adjust the pickup capsule to the required position.
 - The conference base is made of strong and durable zinc alloy, which is artistic and sturdy. Equipped with mute button and working indicator light, it is easy to grasp the status of the equipment.

TDN2 | DESK MICROPHONE WITH DANTE NETWORK OUTPUT



TDN2 is a desktop conference microphone with Dante interface. It adopts a new square microphone tube and a condenser supercardioid capsule to accurately pick up the sound, reducing the interference of ambient noise. The V-shaped base spreads the weight of the microphone more evenly, making it more stable on the table. To connect Relacart TDM digital control software by a Cat5 network cable to enable the microphone to have IP address visualization and customize the microphone's low cut, EQ, light color and volume. The above settings can be copied directly from certain microphone to another through the software. Unique troubleshooting function, when press the CALL button the LED light of the microphone will flash, and the position of the microphone can be quickly found.

Key Features

Dante Audio Transmission Protocol

- With Dante interface, it can communicate with any device with Dante to transmit audio.

Condenser Supercardioid Capsule

- It adopts a new square microphone tube and a condenser supercardioid capsule to accurately pick up the sound, reduce the interference of ambient noise.

V-shaped Base

- V-shaped base spreads the weight of the microphone more evenly, making it more stable on the table.

TDM Digital Control Software

- To connect Relacart TDM digital control software by a Cat5 network cable to enable the microphone to have IP address visualization and customize the microphone's low cut, EQ, light color and volume.

Product Specification



Light touch switch: with LED indicator light, you can change the indicator color through TDM digital microphone control software.



Working status indicator: red light is on when mute, and green light is on when speaking (default color). The microphone LED light corresponding to the microphone can flash through the TDM digital microphone control software, and the corresponding microphone position can be quickly found according to the blinking LED light control software.

Frequency Response:	20Hz-20KHz
Volume Adjustment:	6-level volume adjustable
Low Cut:	150Hz, 18dB/ Octave
S/N Ratio:	65dB, 1KHz at 1Pa
Base Power Supply Mode:	POE IEEE802.3af
Output Interface:	Standard Ethernet interface
Dante Network:	RJ45 connector, above 100Mbps, CAT5 or CAT6 or above
Indicator Light:	LED multi-color adjustable status indicator
Equalizer:	4-band parametric equalizer, set by control software
Microphone up and down adjustment angle degrees:	48°
Power Consumption:	2.3W
Weight:	Approximately 800g
Overall Size (mm):	225(L)× 135(W)× 95/220(H) (minimum angle/highest angle)
Color:	Black/champagne gold

TDN2
Professional Desk Microphone

System Connection Diagram

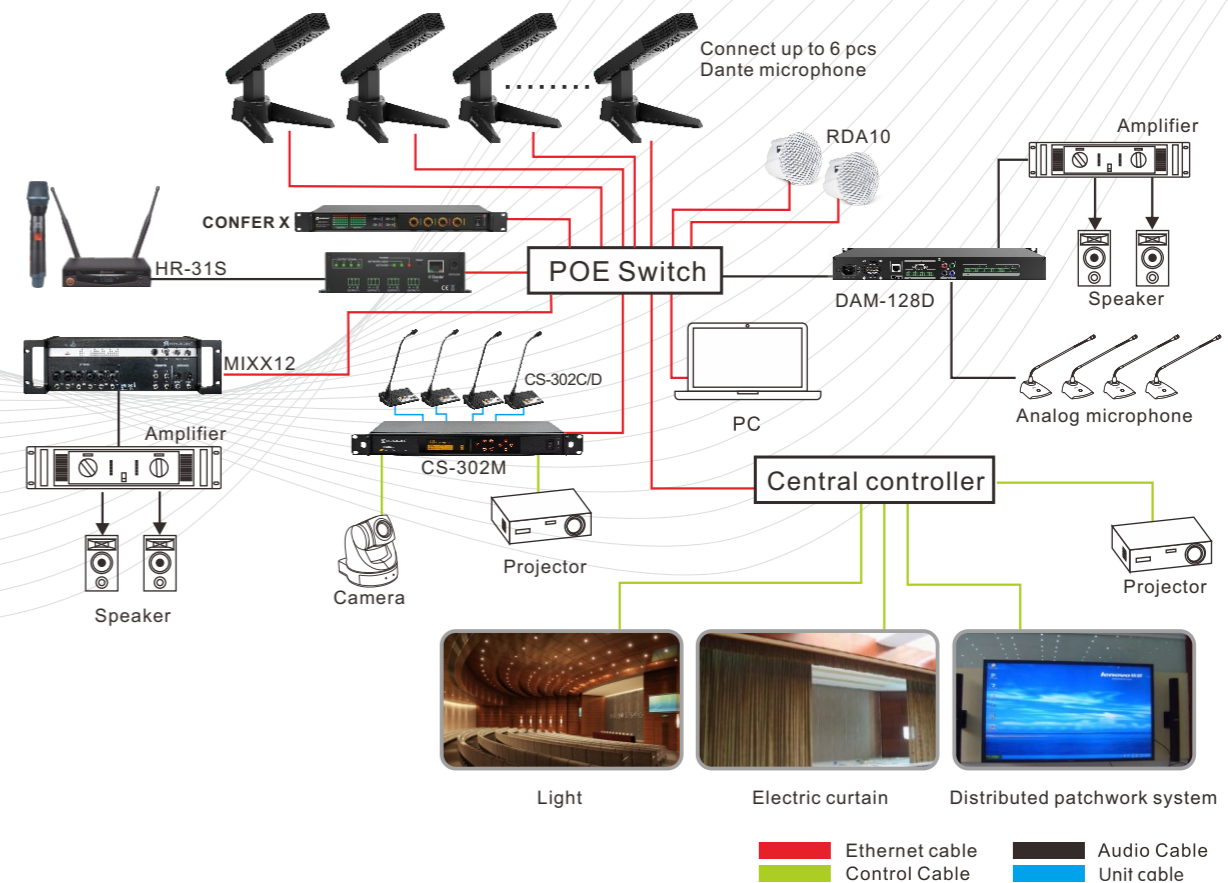

TDN1/TDN1-F

MICROPHONE DESK STAND WITH DANTE NETWORKED OUTPUT



TDN1/TDN1-F desk stand allows Dante technology to be used with any phantom-powered condenser gooseneck microphone with a 3-pin XLRM-type output. The desk stand is designed for surface-mount applications such as high-quality sound reinforcement, conferencing, distance learning and other demanding sound pickup applications.

Product Specification

TDN1

Microphone Desk Stand With Dante Networked Output

XLR Male Connector



TDN1-F

Microphone Desk Stand With Dante Networked Output

XLR Female Connector

• It can be used with the other brands gooseneck microphone.



Frequency Response:	20-20,000Hz
Low Cut:	150Hz, 18 dB/octave
Gain Adjustment:	Six level of adjustable gain
Input Impedance:	2.2 KΩ
Maximum Sound:	0dBu @ +20 dB gain
Input Level:	0dBu @ +20 dB gain
S/N Ratio:	65 dB, 1KHz at 1Pa
Power Requirements:	POE IEEE802.3af standard (Power consumption 1.5W)
Power Consumption:	2.3W
Phantom Power:	48V DC
Input Connector:	3-pin XLRM-Type(TDN1) 3-pin XLRF-Type(TDN1-F)
Output Connector:	RJ45
Cable Required:	CAT5 or CAT6 recommended
Transmission Speed:	100 Mbps
Dimensions(mm):	170(L)×120.3(W)×48.5(H)
Weight:	Approximately 720g

System Connection Diagram

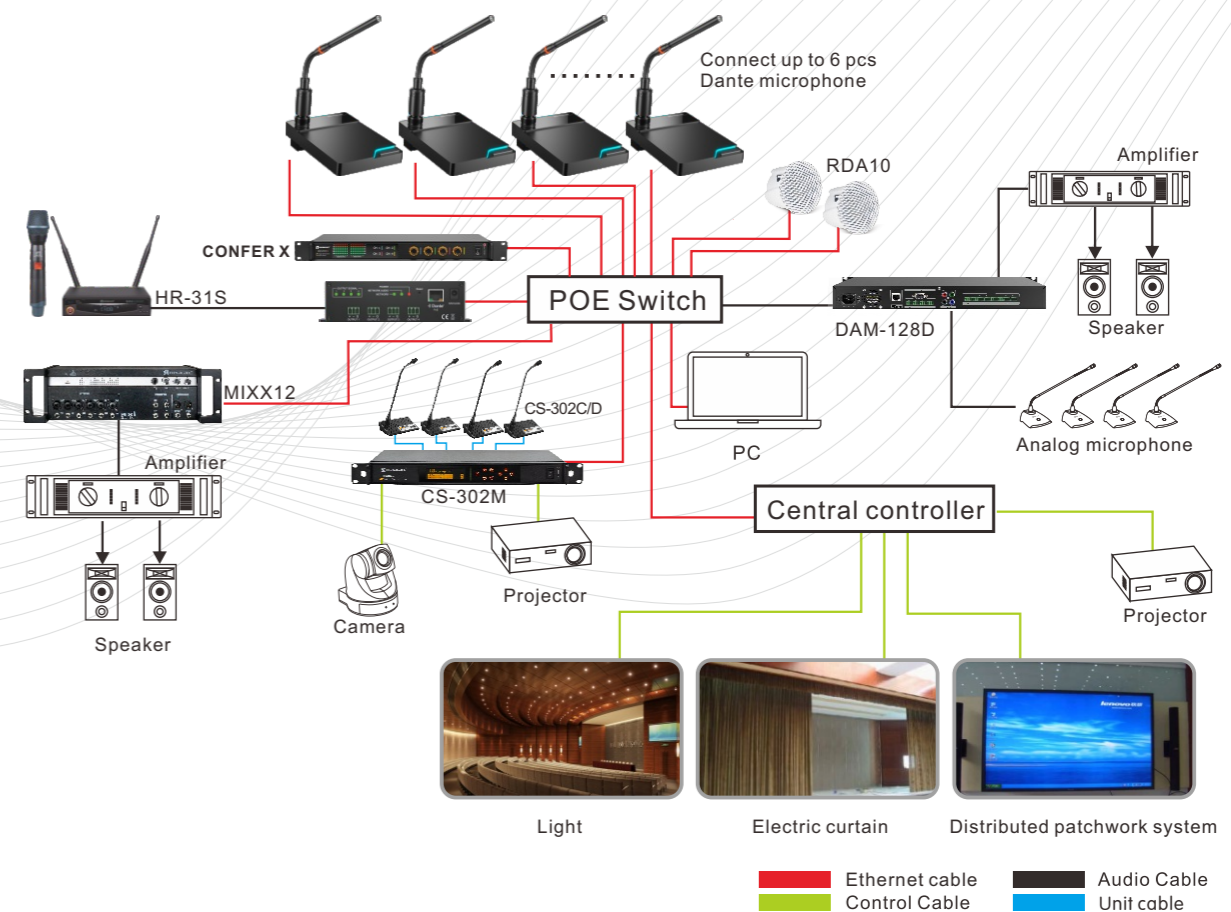

Key Features

Flexible Configuration

- Connect directly to network via Ethernet cable -no need for expensive audio cable or soldering.
- Integrated user switch controls talk/mute in Local mode and triggers.
- Dante-enabled devices in remote mode.
- 3-pin XLRF-type with lock in for quick mounting of gooseneck microphone
- Red/green LED indicator.
- Local or remote control of mic gain, low-cut filter, LED indicator and 48V phantom power.
- Powered by network PoE
- Scalable across Dante's 512 bidirectional audio channels.

Easy Installation

- Filter provides a steep low-frequency attenuation to improve sound pickup without affecting voice quality.
- Heavy die-cast case and non-slip silicone foam bottom pads minimize coupling of surface vibration to the microphone.
- Optional Software: Relacart Dante conference microphone management control softwareRDM1.0, can set microphone input gain, low cut filter, working mode, phantom power. Make the audio gain visible.

Dante™ upgrade card

1. Dante-equipped models enable multi-channel audio networking over Ethernet.
2. Standard Ethernet or Dante™ digital networked audio configurations available
3. Ethernet digital audio of Multi channel, with 24-Bit depth and 48 KHz sample rate
4. Plug and play networking function, with automatic device discovery function and system configuration.
5. Dante upgrade card available for standard Ethernet models.
6. Can use Dante virtual sound card to connect a computer to a Dante network for recording, playback and Internet calling between Dante-equipped devices(download Dante virtual sound card at audinate.com)



ACM-335 | AI CEILING MICROPHONE



Relacart's latest innovation, the ACM-335 AI Ceiling Microphone, combines cutting-edge AI technology and advanced acoustic engineering to deliver unparalleled audio quality for any space. This ceiling-mounted solution is not just a technological breakthrough but a versatile tool for environments like conference rooms, classrooms, and auditoriums, ensuring every word is captured with precision and clarity.



Product Specification



ACM-335
AI Ceiling Microphone

R-M15
Pole Mount Kit for ceiling microphone

Coverage Area:	25x25 ft (7.6x7.6 m)
Coverage Type:	Automatic
Power Requirements:	PoE/PoE+ (IEEE 802.3af/at)
Power Consumption:	Max 3W
Control Software:	TDM
Cable Requirement:	Cat5e or higher (shielded recommended)
Connector Type:	RJ45
Plenum Rating:	UL2043 (suitable for air-handling spaces)
Dust Protection:	IEC 60529 IP5X
Operating Temperature:	-5°C (23°F) to 40°C (104°F)
Storage Temperature:	-25°C (-13°F) to 60°C (140°F)

Microphone Parameters

Microphone Element:	5 MEMS arrays
Frequency Response:	100Hz – 8kHz
AES67/Dante Output – Channels:	1 channel
AES67/Dante Output – Sample Rate:	48kHz
AES67/Dante Output – Bit Depth:	24-bit
Sensitivity (at 1kHz):	-1.5dBFS/Pa
Max SPL:	96dB SPL
SNR (ref. 94dB SPL, 1kHz):	75dB (A-weighted)
Latency (excl. Dante latency):	48ms
Self-Noise:	22dB SPL (A-weighted)
Dynamic Range:	75dB
Dimensions(mm):	335(Φ)×33(D)

Digital Signal Processing

Acoustic Echo Cancellation (AEC)
AI Noise Reduction
Auto Gain Control (AGC)
Mute Function

Key Features

360° AI Noise Reduction

- Removes background noise from both uplink and downlink communications while preserving voice clarity, enabling natural conversations in any setting.

Intelligent De-reverberation

- Utilizes Deep Neural Networks (DNN) to eliminate echoes in reflective spaces (e.g., concert halls), enhancing Direct-to-Reverberant Ratio (DRR) for crystal-clear voice reproduction.

Full-Duplex Acoustic Echo Cancellation

- Eliminates echoes even during simultaneous speech, ideal for low Signal-to-Noise Ratio (SNR) environments without relying on mechanical design.

Dynamic Feedback Suppression

- Integrated AI processor instantly identifies and suppresses narrow band feedback between speakers and microphones, ensuring stable, distortion-free audio.

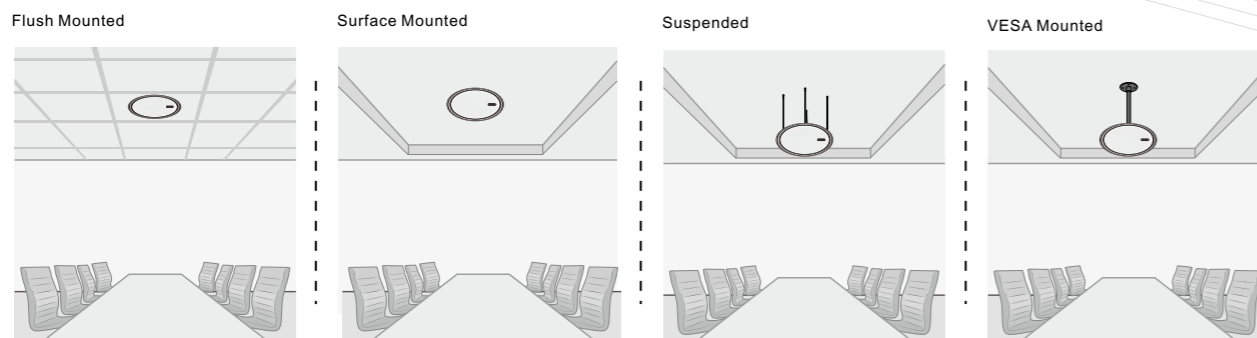

* Observe the mounting specifications from the manufacturer. When flush mounting, do not install the ACM-335 directly next to lights or other electrical devices in the ceiling.

www.relacart.com/tools-and-software

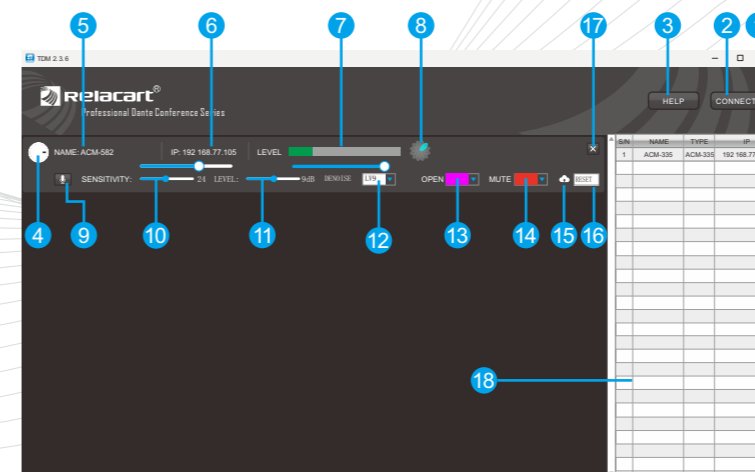
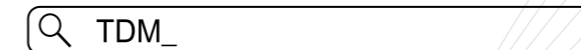

- Download the software. Double-click the TDM software icon to open the software.
- Click on the CONNECT key at the top right of the software interface to connect.
- TDM software window (Minimize/Enlarge/Close)
- Device connect button
- Device help button
- Microphone outline
- Microphone name
- IP address
- Microphone level status
- Microphone pattern
- Microphone mute switch
- Microphone sensitivity control
- Microphone main level gain
- Noise reduction level setting
- Microphone open state color custom selection
- Microphone mute status color custom selection
- Firmware Upgrade
- Microphone to restore factory Settings
- Close button of microphone function window
- Microphones list

ACM-582 | AI CEILING MICROPHONE



Relacart's latest innovation, the ACM-582 AI Ceiling Microphone, combines cutting-edge AI technology and advanced acoustic engineering to deliver unparalleled audio quality for any space. This ceiling-mounted solution is not just a technological breakthrough but a versatile tool for environments like conference rooms, classrooms, and auditoriums, ensuring every word is captured with precision and clarity.



Product Specification



ACM-582
AI Ceiling Microphone

R-M15 R-M16
Pole Mount Kit for ceiling microphone

Coverage Area:	25x25 ft (7.6x7.6 m)
Coverage Type:	Automatic
Power Requirements:	PoE/PoE+ (IEEE 802.3af/at)
Power Consumption:	Max 3W
Control Software:	TDM
Cable Requirement:	Cat5e or higher (shielded recommended)
Connector Type:	RJ45
Plenum Rating:	UL2043 (suitable for air-handling spaces)
Dust Protection:	IEC 60529 IP5X
Operating Temperature:	-5°C (23°F) to 40°C (104°F)
Storage Temperature:	-25°C (-13°F) to 60°C (140°F)

Microphone Parameters

Microphone Element:	5 MEMS arrays
Frequency Response:	100Hz – 8kHz
AES67/Dante Output – Channels:	1 channel
AES67/Dante Output – Sample Rate:	48kHz
AES67/Dante Output – Bit Depth:	24-bit
Sensitivity (at 1kHz):	-1.5dBFS/Pa
Max SPL:	96dB SPL
SNR (ref. 94dB SPL, 1kHz):	75dB (A-weighted)
Latency (excl. Dante latency):	48ms
Self-Noise:	22dB SPL (A-weighted)
Dynamic Range:	75dB
Dimensions(mm):	582(W)x582(H)x52(D)

Digital Signal Processing

Acoustic Echo Cancellation (AEC)
AI Noise Reduction
Auto Gain Control (AGC)
Mute Function

Key Features

360° AI Noise Reduction

- Removes background noise from both uplink and downlink communications while preserving voice clarity, enabling natural conversations in any setting.

Intelligent De-reverberation

- Utilizes Deep Neural Networks (DNN) to eliminate echoes in reflective spaces (e.g., concert halls), enhancing Direct-to-Reverberant Ratio (DRR) for crystal-clear voice reproduction.

Full-Duplex Acoustic Echo Cancellation

- Eliminates echoes even during simultaneous speech, ideal for low Signal-to-Noise Ratio (SNR) environments without relying on mechanical design.

Dynamic Feedback Suppression

- Integrated AI processor instantly identifies and suppresses narrow band feedback between speakers and microphones, ensuring stable, distortion-free audio.

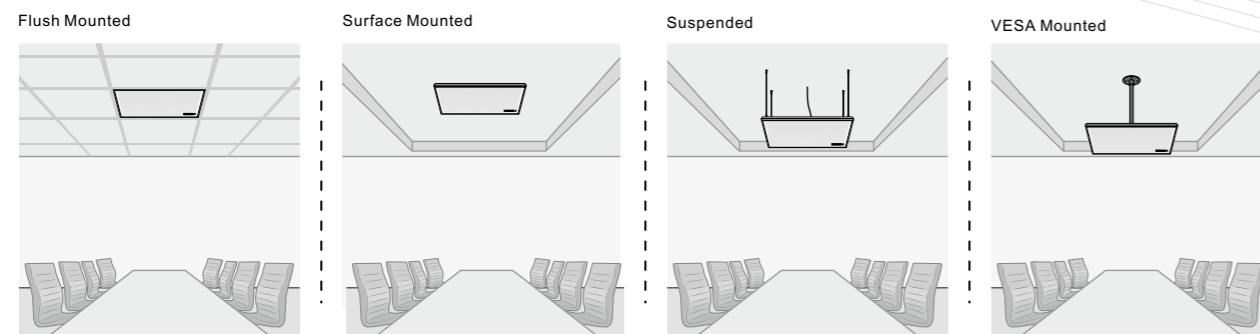

* Observe the mounting specifications from the manufacturer, When flush mounting, do not install the ACM-582 directly next to lights or other electrical devices in the ceiling.

www.relacart.com/tools-and-software

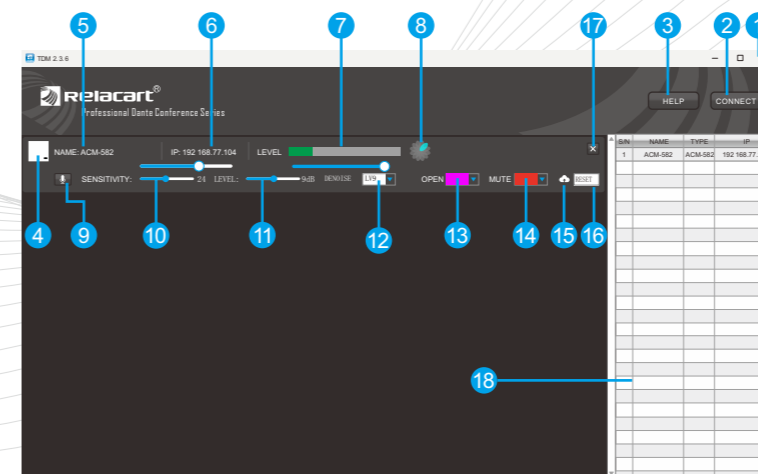
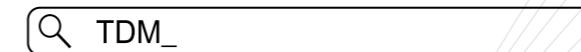

- Download the software, Double-click the TDM software icon to open the software.
- Click on the CONNECT key at the top right of the software interface to connect.
- TDM software window (Minimize/Enlarge/Close)
- Device connect button
- Device help button
- Microphone outline
- Microphone name
- IP address
- Microphone level status
- Microphone pattern
- Microphone mute switch
- Microphone sensitivity control
- Microphone main level gain
- Noise reduction level setting
- Microphone open state color custom selection
- Microphone mute status color custom selection
- Firmware Upgrade
- Microphone to restore factory Settings
- Close button of microphone function window
- Microphones list

RDA10

DANTE-ENABLED 6.25" COAXIAL CEILING LOUDSPEAKER



The RDA10 is a cost-effective full-frequency 6.25-inch coaxial ceiling loudspeaker with a Class D digital audio amplifier that delivers up to 30W of power. It has built-in full-band coaxial ceiling loudspeakers that are easy and quick to install using standard bend clips. With its bezel free structure and exquisite slim design, it can be cleverly integrated into the ceiling environment, making it an ideal choice for hotels, conference rooms, shopping malls, educational institutions, hospitals, retail stores, performing arts centers, restaurants, airports, chapels and board rooms.

RDA20

DANTE AUDIO NETWORKED ENABLED SPEAKER



The RDA20 is an integrated active full frequency speaker with network transmission and pure digital power amplifier. The speaker is powered by PoE/PoE+ network switch meaning no external power supply is required. The speaker includes a Class D amplifier which provides. Connect a network cable to communicate with the built-in Dante module to realize network audio signal transmission. By automatically assigning an IP address through the router DHCP, it can transmit signals with Dante's audio matrix in the LAN, and it is easy to set up a full digital network sound reinforcement system. Suitable for education, hospitals, small and medium-sized conference rooms, restaurants, houses of worship and other places.

Key Features

DSP DSP Audio Digital Extension

- The high-speed DSP chip and self-developed digital audio extension algorithm are used to reduce the noise caused by audio transmission.

Quick Installation

- It can be installed easily and quickly by using standard bending clamp. The shape adopts a frameless structure and exquisite thin design, which can be cleverly integrated into the ceiling environment, making it a hotel, conference room, shopping center, educational institution, hospital, retail store, performing arts center and other places.

PoE Power Supply

- The latest standard specification for the simultaneous transmission of DATA and electrical power using existing standard Ethernet transmission cables while maintaining compatibility with existing Ethernet systems and users.

Dante Network Audio Protocol

- Built-in Dante module communication to achieve network audio signal transmission. The IP address can be automatically assigned through DHCP router, and the signal can be transmitted with Dante audio matrix in the LAN, and a set of digital network sound reinforcement system can be easily established.

Product Specification



RDA10
Dante-Enabled 6.25" Coaxial Ceiling Loudspeaker

Power Supply:	Standard PoE/PoE+
Power Supply Voltage:	37V-57V
Input Mode:	Dante input
Output Power:	PoE 10W/PoE+ 20W
Frequency Response (-3dB) :	90Hz-16KHz
Sensitivity:	90dB
Sound Pressure Level Output (-6dB) :	110dB/RMS, 113dB/peak
Coverage Angle:	Horizontal 90° /vertical 90°
Socket:	RJ45 JACK
Installation Opening Size(mm):	Φ190
Size(mm):	210(W)×150(D)
Weight:	About 1.8kg

Key Features

Functional Diversification

- It has perfect protection functions (short circuit protection, overcurrent protection, over and under protection, DC protection, overheating protection, power voltage limit, clipping limiter), high efficiency and high sound energy output, excellent sound quality, perfect protection functions and good electromagnetic compatibility characteristics

Dante Network Mode

- Full frequency speaker integrating network transmission and pure digital power amplifier

Intelligent IP Allocation

- Automatically assign IP addresses through router DHCP

PoE Power Supply

- The latest standard specification for the simultaneous transmission of DATA and electrical power using existing standard Ethernet transmission cables while maintaining compatibility with existing Ethernet systems and users.

XLR XLR Socket

- XLR RJ45 socket

Product Specification



RDA20
Dante Audio Networked Enabled Speaker

Power Supply:	Standard PoE / PoE +
Power Supply Voltage:	37V-57V
Input Mode:	Dante input
Output Power:	PoE 10W / PoE + 20W
Frequency Response (-3dB):	85Hz-17KHz
Sound Pressure Level Output (-6dB):	110dB / aes continuous; 113dB / peak
Coverage Angle:	Horizontal / vertical 90° / 90°
Input jack:	RJ45
Size(mm):	132(W)×160(D)×236(H)
Weight:	About 2.93kg
Accessories:	Wall bracket

RDM Software Introduction

1.Connection method

1. Double-click the  software icon to open the software.
2. Click on the **CONNECT** button at the top right of the software interface to connect.

2.Key features of the software

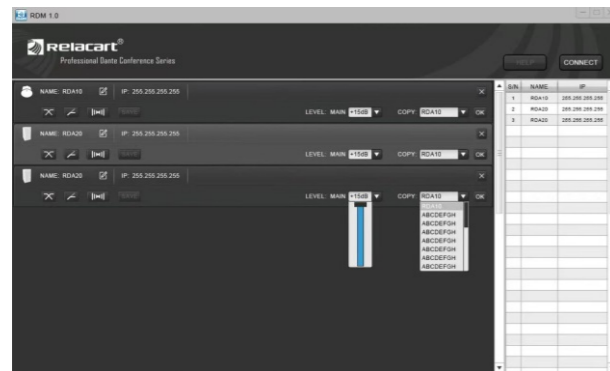

Simple and easy-to-use management interface, display the name and IP of the device, convenient and accurate control of each device

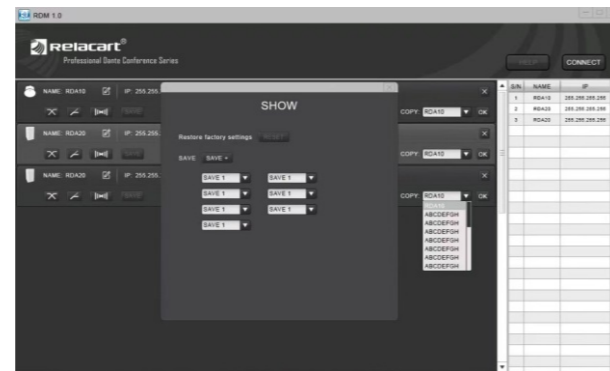

Preset parameters can be saved and read, and the parameters of any device in the LAN can also be copied with one click

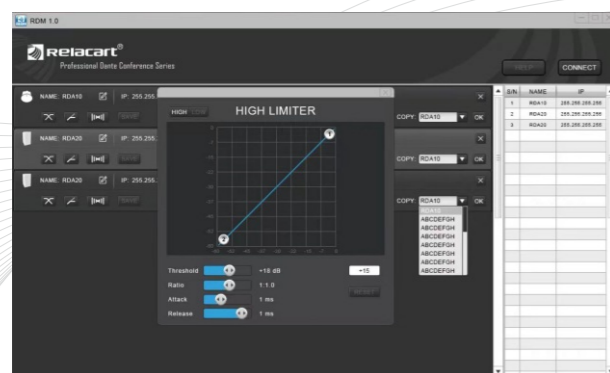

The tweeter and woofer LIMITER parameters can be set independently



Both the tweeter and woofer can be set with 7-band equalization, high-pass filter and low-pass filter independently

TDM Software Introduction

1.Connection method

1. Double-click the  software icon to open the software.
2. Click on the **CONNECT** button at the top right of the software interface to connect.

2.Key features of the software

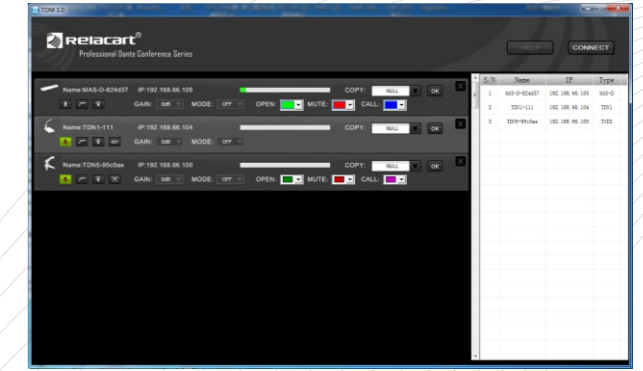
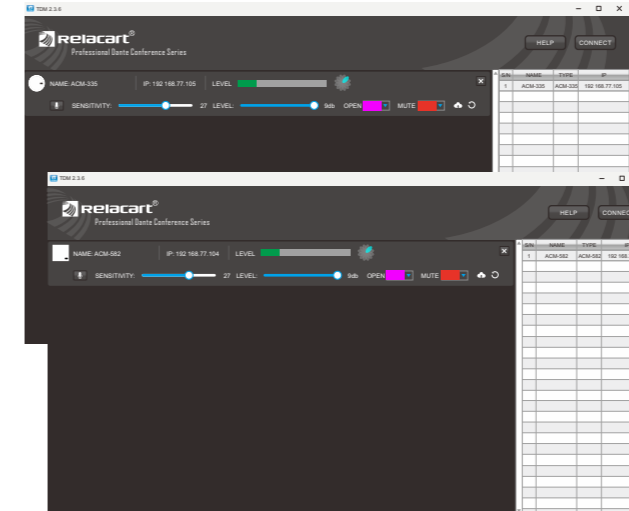

Remotely control microphone mute, gain, low-cut switch, and work mode(ON/OFF/PTM/PTT) . The parameters of the same model microphone in the same LAN can be copied with one click

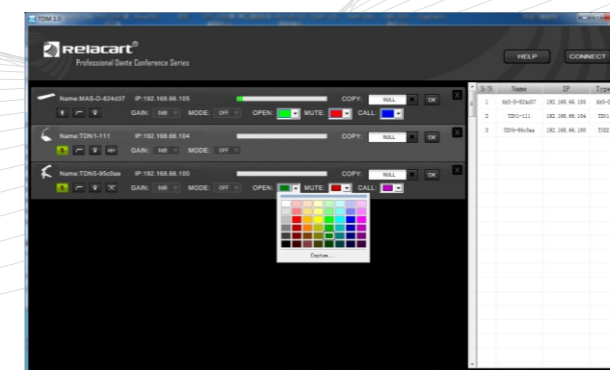

Some microphones support custom LED light color, you can customize the color of the indicator light in speaking state, mute state and call state through software

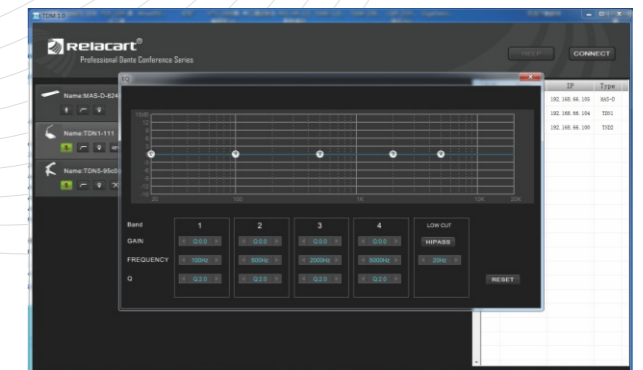

Some microphones support equalization adjustment function, 4-band equalization and high-pass filter can be set by software

Product Specification

TSG-923
Professional Desk
Microphone



• TSG-923/933 is a desktop conference microphone with a three-pin XLR male. It adopts a new square microphone tube and high-end customized leather material, which is elegant and generous. The V-shaped base distributes the weight of the microphone more evenly, making it more stable on the table. The condenser cardioid directivity microphone core and the adjustable pickup angle design are adopted, which can flexibly adjust the pickup direction according to personal usage habits. Placing it in a farther place gives participants more space, and at the same time, it can also reduce the interference of environmental noise by using the principle of lower sensitivity of the end.

Capsule Type:	Condenser
Polar Pattern:	Cardioid
Frequency Response:	100Hz-15KHz
Sensitivity:	-38dB at 1V at 1Pa
Output Impedance:	420Ω
Maximum Sound Pressure:	125dB, 1KHz at 1% T.H.D
Dynamic Range (Typical):	100dB, 1KHz at maximum sound pressure
S/N Ratio:	>65dB, 1KHz at 1Pa
Power Supply:	DC24-52V phantom
Power Switch:	On/Mute
Output Connector:	Male 3-pin XLR
Weight:	About 800g
Overall Size(mm):	225(W) x 135 (D)X95/220(H) (minimum angle/highest angle)
Colour:	TSG-923:Black TSG-933:Champagne gold

TSG-933
Professional Desk
Microphone



TSG-902
Professional Desk
Microphone



• TSG-902 is a wide frequency response condenser super directional microphone, with high quality sound pickup function. It is designed to the sound reinforcement, professional recording, television, broadcast, conference and other demanding high quality sound pickup applications.

Capsule Type:	Condenser
Polar Pattern:	Super Cardioid
Frequency Response:	80Hz-18KHz
Sensitivity:	-30dB at 1V at 1Pa
Impedance:	250Ω
Maximum Sound Pressure:	125dB, 1KHz at 1% T.H.D.
Dynamic Range :	100dB, 1KHz at maximum sound pressure
S/N Ratio:	110dB, 1KHz at 1% T.H.D.
Power Supply:	DC24-52V phantom
Switch:	On/Mute
Output Connector:	phoenix terminal connector / euroblock
Dimensions(mm):	170(W) x 270 (D)X120(H)
Weight(g):	About 825g

Product Specification

TSG-600
Professional Desk
Microphone



Capsule Type:	Condensers
Polar Pattern:	Cardioid
Frequency Response:	80Hz~18KHz
Sensitivity:	-32 dB (17.7mV) 1Pa at 1V
Impedance:	250Ω
Maximum Sound Pressure:	125 dB SPL, 1KHz at 1% T.H.D
Dynamic Range(Typical):	105 dB, 1 kHz at Max SPL
S/N Ratio:	>65dB, 1kHz at 1Pa
Switch:	Mute
Power Supply:	11-52V DC, 4 mA typical
Weight:	996g
Microphone Length(mm):	340,420(standard),480
Output Connector:	Male 3-pin XLR
Accessories Furnished:	Windscreen
Color:	Black

RG-10
Professional Desk
Microphone



Capsule Type:	Condenser
Polar Pattern:	Super Cardioid
Frequency Response:	50Hz~18KHz
Sensitivity:	- 47dB, f =1KHz @ 1V / Pa
Impedance:	2900Ω
Maximum Sound Pressure:	120 dB SPL, 1KHz at 1% T.H.D
Dynamic Range(Typical):	115 dB, 1 kHz at Max SPL
S/N Ratio:	>65dB, 1kHz at 1Pa
Switch:	(on circuit board) Mute/Toggle/Talk
Power Supply:	48V DC , 8 mA typical
Output Connector:	Male 3-pin XLR
Microphone Length(mm):	148(L) x 115(W) x 233(H)
Weight:	715g

Product Specification



TS-N1
Gooseneck Microphone
Desk Stand



TS-F1
Gooseneck Microphone
Desk Stand

- The TS-N1/TS-F1 is equipped with a blue/green LED indicator. The user can use the microphone to mute or speak operation, where the toggle between talk and mute can be programmed to toggle between live and mute audio (Latch switch on/off). Either preset to mute and only speak when pressed (press to talk), or preset to speak and only mute when pressed (press to mute). Low-impedance balanced audio output, the audio signal is output through the + and - pins of the XLR male header, and the G pin is connected to the ground (shield), and the output phase will be set on the + pin with a positive phase level.
- TS-N1: Matching microphone: GS-838/GS-450/EG-118/AL-19F/MS-923/MS-933
- TS-F1: Matching microphone: GS-380/EG-118/AL-19F

Frequency Response:	50Hz~20KHz
Impedance:	250Ω
Dynamic Range (typical):	100dB, 1KHz at maximum sound pressure
S/N ratio:	110dB, 1KHz at 1% T.H.D.
Switch:	On/Mute
Power Supply:	DC 24-52V phantom power supply
Output Connector:	phoenix terminal connector / euroblock
Weight:	700-720 g
TS-N1: Input socket:	3-pin XLR male socket
TS-F1: Input socket:	3-pin XLR female socket

Product Specification



TS-800/TS-800S
Gooseneck Microphone Desk Stand
(XLRF - type)



TS-800M/TS-800SM
Gooseneck Microphone Desk Stand
(XLRM - type)

- TS-800/800S/800M/800SM anti-shock and an integral mute switch microphone stand effectively isolate mounted microphone from impact vibration and mechanical noise normally transmitted from the surface.
- It is intended for use with microphones stood on lecterns, pulpits, conference tables and similar surfaces.
- Matching microphone: GS-838/GS-450/EG-118/AL-19F/MS-923/MS-933

Switch (TS-800S):	Muted switch(1KHz at 55dB attenuation)
Phantom Power Requirements:	24-48V DC, 3 mA typical
Connector:	XLRF - type XLRM - type
Dimensions(mm):	126(W)×152(D)×57(H)
Weight:	952g



Product Specification



FM-200
Flush-mount
Microphone Socket

- FM-200 is a recessed, conference microphone socket designed for desktop installation. It has a touch switch control and is also equipped with a ring-shaped LED status indicator, which displays green when the microphone is in the radio state and red when it is muted. The input end is a 3-pin XLR female socket, and the output end is a 3-pin XLR male header.

Frequency Response:	50~20,000Hz
Mute Attenuation:	<50dB at 1kHz/Pa
LED Indicator:	Radio status is green / mute status is red
Phantom Power Supply:	DC 20-52V, power consumption 4.5mA typical
Switch:	Touch mode, mute state by default when power on
Weight:	310g
Dimensions(mm):	59.2×59×156.5(L)
Input Interface:	3-pin XLR female
Output Interface:	3-pin XLR male
Random Accessories:	Anti-vibration rubber*1, metal fixing ring*1



FM-300
Flush-mount Microphone
Socket with Logic I/O

- The FM-300 is an embedded conference microphone base designed for desktop installation.
- The socket's logic out capability permits control of remote devices from a programmable capacitance switch, so users can easily trigger an external device (e.g., a camera or light) with the touch of a button – an extremely useful feature in conference and boardroom installations.

Frequency Response:	50~20,000Hz
Switch Logic Control:	High potential (DC +5V) when pressed; Low potential (DC 0V) when not pressed
LED Indicator:	Red: high level (DC +5V) Green: Low level (DC 0V)
Phantom Power Supply:	DC 20-52V, power consumption 4.5mA typical
Switch:	Touch mode, mute state by default when power on
Weight:	310g
Dimensions(mm):	59.2×59×156.5(L)
Input Interface:	3-pin XLR female
Output Interface:	5-pin XLR male
Random Accessories:	Anti-vibration rubber*1, metal fixing ring*1

Application:

- The socket needs DC 20V to 52V phantom power supply to work, and the electronic circuit in the socket needs 30 seconds to work stably after being powered on.
- Each socket is equipped with an anti-vibration rubber ring and a set of metal retaining rings (for use with gooseneck microphones) to reduce vibration noise on the mounting surface. The housing is a metal structure.

Key Features

Practical Function

- Flush-mounted microphone socket, suitable for use with gooseneck microphones with 3-pin XLR male output.
- For unobtrusive installation on desktop.
- Connect the microphone with 3-pin XLR female, 3-pin XLR male output (XLRM)
- Equipped with anti-vibration rubber and metal fixing ring (used with gooseneck microphone) to reduce vibration noise on the installation surface.
- The working range of socket power supply is DC 20-52V.

Touch-Sensitive Control

- Design with momentary Touch-sensitive button, can control microphone mute

LED Ring Indicator Light

- The indicator shows green when the microphone is on. It will show red when the microphone is in mute status.

Logic Out Capacity

- Features with logic out capacity, users can connect an external device for further control (e.g., a camera or light).

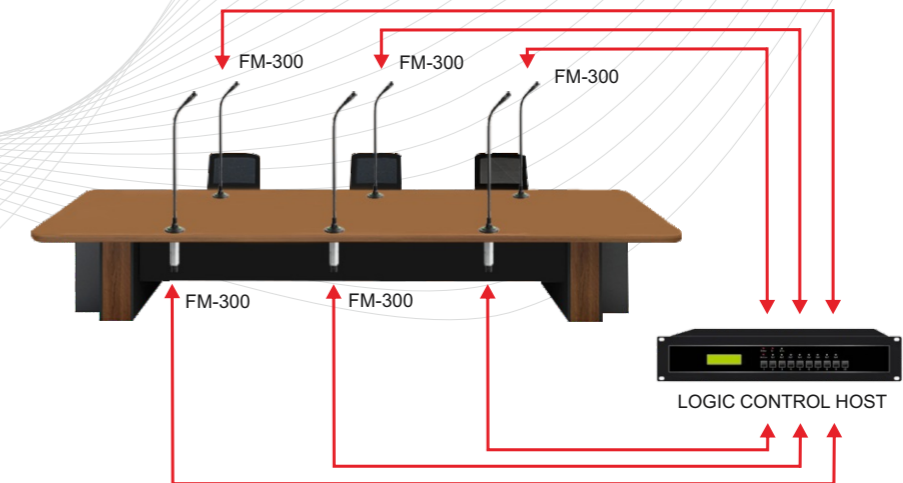

AL/GS/EG/ES series

CONDENSER GOOSENECK MICROPHONE WITH MUTE SWITCH



AL-19N/19T/19F series is a wide range miniature condenser microphone with cardioid orientation. It is designed for high-quality sound reinforcement, professional recording, television and other demanding polar applications. The small diameter double gooseneck design allows for highly flexible positioning while maintaining a smooth, contoured appearance.



GS-380/450/530 gooseneck microphone is a wide-range condenser Cardioid directivity professional microphone, dual gooseneck microphone design, built-in audio frequency transformer, the effect of high quality sound pickup. It is designed for professional recording, television broadcasting, meetings and other occasions.



EG-115/118/121 is wide-range miniature condenser microphone, dual gooseneck microphone pole design, high quality sound pickup. Widely apply to professional recording, broadcast and conference occasions. There is mini hidden low cut switch, can set 100Hz high pass filter and flat respond.



ES-910 gooseneck microphone is a professional microphone which is wide-range condenser super directivity, built-in audio transformer and have high quality pick up effect. This microphone is suitable for seminar, middle to large meeting, television broadcasting and professional recording.



AL-19N/19T/19F
Gooseneck Microphone

Capsule Type: Condenser
Polar Pattern: Cardioid
Frequency Response: 80Hz-18KHz
High Pass Filter: 100Hz, 18dB/octave
Turn-on Sensitivity: -32dB, at 1V at 1Pa
Impedance: 200Ω
SPL: 127 dB, 1KHz at 1% T.H.D
Dynamic Range(Typical): 110dB, 1KHz at max. SPL
Switch: Flat, high pass filter
S/N Ratio: >68dB, 1KHz at 1Pa
Phantom Power Requirements: 11-52V DC
Consumption: 5mA typical
Dimensions/Weight: AL-19N: 380mm, 150g
AL-19T: 450mm, 170g
AL-19F: 530mm, 190g
Output Connector: Male 3-pin XLR
Best Distance for Sound Pickup: 10cm-20cm
Color: Black

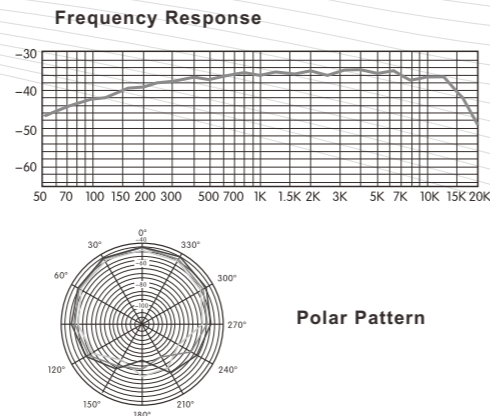

Anti-Interference

- The gooseneck microphone outer shell is made by pure copper, cooperating ORF shielding technology, offer excellent anti-interference capability, avoid the interference from the cell phone or other wireless devices.

Flexible Adjustment

- Easy to adjust, durable, delicate gooseneck structure, enable to quickly and randomly fix the capsule in a suitable position other wireless devices.

Clear Sound Quality

- The gooseneck microphone with low cut switch avoid "popping", cooperating with super low impedance output, very clear sound quality, much better than the normal phantom conferencing microphone.

Phantom Power

- The integral power module can be powered from any external 11V to 52V DC phantom power supply.

Product Specification



GS-380/450/530
Gooseneck Microphone

Capsule Type: Condenser
Polar Pattern: Cardioid
Frequency Response: 35-18,000 Hz
Low Frequency Roll-Off: 100Hz, 18 dB / octave
Open Circuit Sensitivity: -32dB (10.0 mV) re 1V at 1Pa
Impedance: 250Ω
SPL: 130 dB, 1KHz at 1% T.H.D
Dynamic Range(Typical): 110dB, 1KHz at max. SPL
S/N Ratio: >68dB, 1KHz at 1Pa
Phantom Power Requirements: 11-52V DC
Consumption: 5mA typical
Dimensions/Weight: GS-380:380mm, 150g
GS-450:450mm, 170g
GS-530:530mm, 190g
Output Connector: Male 3-pin XLR
Best Distance for Sound Pickup: 10cm-20cm
Color: Black

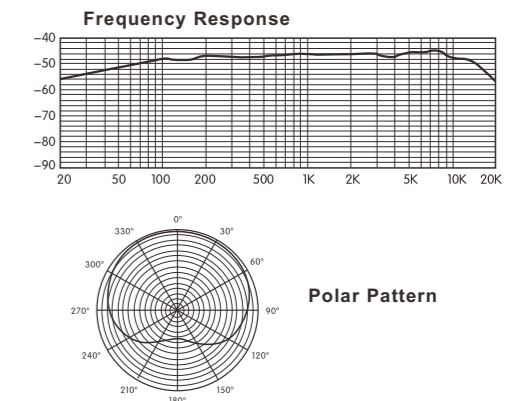

EG-115/118/121
Gooseneck Microphone

Capsule Type: Condenser
Polar Pattern: Cardioid
Frequency Response: 20Hz-20KHz
Low Frequency Roll-Off: 50Hz, 18 dB / octave
Open Circuit Sensitivity: -44dB 1V at 1Pa
SPL: 120 dB, 1KHz at 1% T.H.D
Dynamic Range(Typical): 115dB, 1KHz at max. SPL
Impedance: 280Ω
S/N Ratio: >72dB, 1KHz at 1Pa
Phantom Power Requirements: 11-52V DC
Consumption: 4mA typical
Dimensions/Weight: EG-115:380mm, 150g
EG-118:450mm, 170g
EG-121:530mm, 190g
Output Connector: Male 3-pin XLR
Best Distance for Sound Pickup: 10cm-20cm
Color: Black

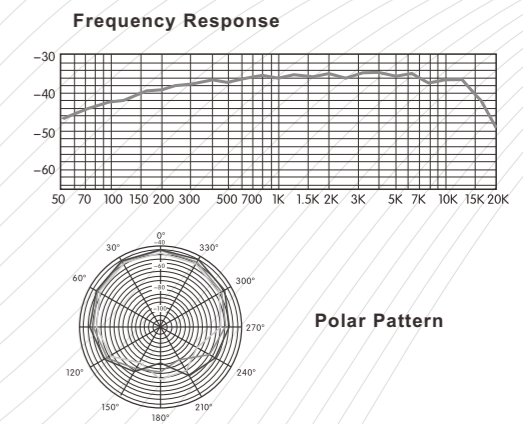

ES-910
Gooseneck Microphone

Capsule Type: Condenser
Polar Pattern: Super cardioid
Frequency Response: 30Hz-18KHz
Low Frequency Roll-Off: 100Hz, 18 dB / octave
Open Circuit Sensitivity: -30dB (10.0 mV) re 1V at 1Pa
Output Impedance: 250Ω
SPL: 130 dB, 1KHz at 1% T.H.D
Dynamic Range(Typical): 110dB, 1KHz at max. SPL
S/N Ratio: >68dB, 1KHz at 1Pa
Phantom Power Requirements: DC11-52V DC
Consumption: 5mA (typical)
Dimensions: 330mm
Weight: 180g
Output Connector: Female 3-pin XLR
Best Distance for Sound Pickup: 10cm-75cm
Color: Black

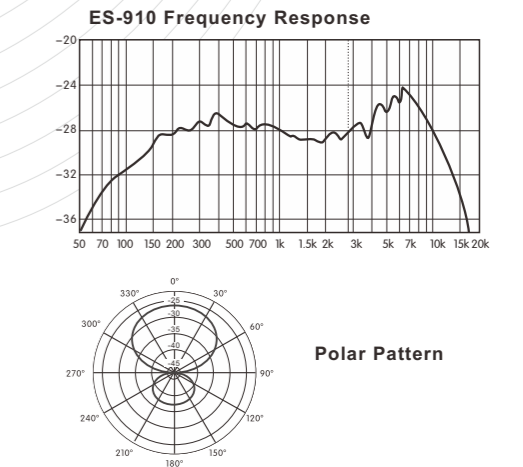

CF/GF/MS series

CONDENSER GOOSENECK MICROPHONE WITH MUTE SWITCH

Product Specification



CF-100
Gooseneck Microphone

CF-100 is a locking three pin balanced XLR female microphone microphone rod, which can firmly lock the base of the conference microphone to prevent various failures caused by looseness or poor contact. It has LED ring indicator light ring, which can tell the working state of the microphone through the light and dark of the light ring.

Capsule Type: Condenser
Polar Pattern: Cardioid
Frequency Response: 50Hz-18KHz
Sensitivity: -47dB 1V at 1Pa
SPL: 110 dB, 1KHz at 1% T.H.D
Dynamic Range(Typical): 115dB, 1KHz at max. SPL
Impedance: 680Ω
S/N Ratio: >52dB, 1KHz at 1Pa
Power Supply: 5V DC
Consumption: 4mA typical
Output Connector: Female 3-pin XLR
Dimensions: 450mm
Weight: About 145g

Frequency Response

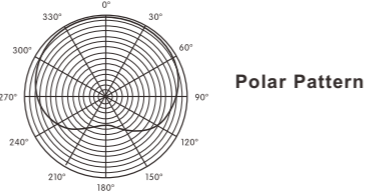
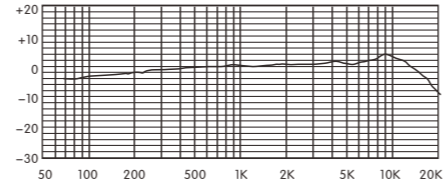

Polar Pattern

GF-101/301/501 is a locking three pin balanced XLR female microphone microphone rod, which can firmly lock the base of the conference microphone to prevent various failures caused by looseness or poor contact. It has LED ring indicator light ring, which can tell the working state of the microphone through the light and dark of the light ring. FI shielding technology can effectively suppress external RF interference, and different appearances and lengths can be selected.

Capsule Type: Condenser
Polar Pattern: Cardioid
Frequency Response: 100-15000Hz
Sensitivity: -47 dB/1kHz at 1Pa
SPL: 105dB SPL/1kHz at 1% THD
Impedance: 680Ω
S/N Ratio: >52dB/1kHz at 1Pa
Power Supply: 5V DC
Output Connector: Female 3-pin XLR
Dimensions/Weight: GF-101: 455mm, 165g
GF-301: 415mm, 195g
GF-501: 412mm, 190g

Frequency Response

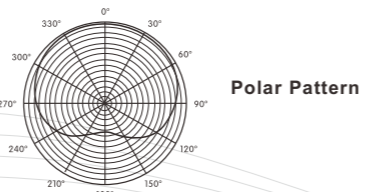
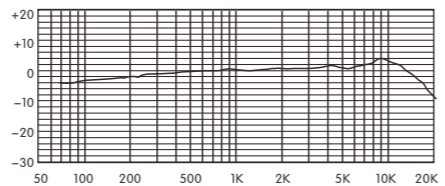

Polar Pattern

GF-101/301A/501
Gooseneck Microphone

GF-901 is a locking three pin balanced XLR female microphone microphone rod, which can firmly lock the base of the conference microphone to prevent various failures caused by looseness or poor contact. It has LED ring indicator light ring, which can tell the working state of the microphone through the light and dark of the light ring. FI shielding technology can effectively suppress external RF interference.

Capsule Type: Condenser
Polar Pattern: Super Cardioid
Frequency Response: 100Hz-15KHz
Sensitivity: -43dB 1V at 1Pa
SPL: 110 dB, 1KHz at 1% T.H.D
Impedance: 680Ω
S/N Ratio: >55dB, 1KHz at 1Pa
Power Supply: 5V DC
Output Connector: Female 3-pin XLR
Dimensions: 310mm
Weight: About 170g

Frequency Response

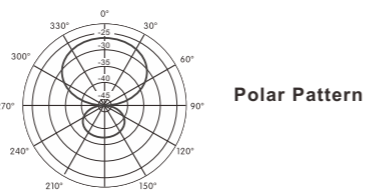
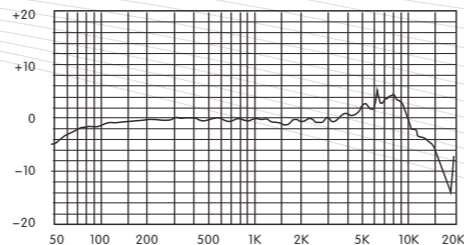

Polar Pattern

GF-901
Gooseneck Microphone

Product Specification



GF-902
Gooseneck Microphone

GF-902 is a locking three pin balanced XLR female microphone microphone rod, which can firmly lock the base of the conference microphone to prevent various failures caused by looseness or poor contact. It has LED ring indicator light ring, which can tell the working state of the microphone through the light and dark of the light ring. FI shielding technology can effectively suppress external RF interference.

Capsule Type: Condenser
Polar Pattern: Super Cardioid
Frequency Response: 50Hz-20KHz
Sensitivity: -20dB±-3dB(0dB=1V/Pa,f=1KHz)
SPL: 110dB(THD<5%, f=1KHz)
S/N Ratio(A weighted): >100dB(THD<1%,f=1 KHz)
Distortion: <0.1%
Power Supply: 5V DC
Output Connector: XLRM
Dimension (mm): 285 (L)
Weight: About 180g
Color: metallic gray

Frequency Response

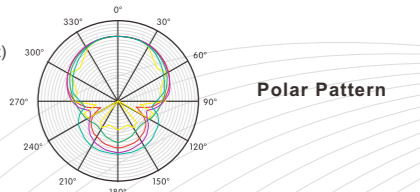
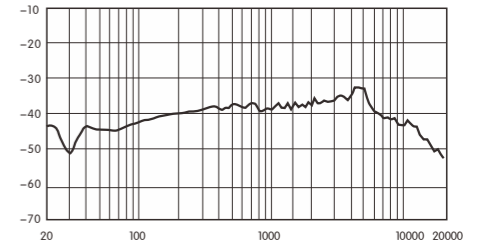

Polar Pattern

The MS-923/933 is a microphone with a three pin XLR female. The new square microphone tube and condenser cardioid microphone capsule can accurately pick up the sound and reduce the interference of environmental noise by using the principle of low terminal sensitivity. With 48V phantom power supply, it can support multiple bases within the rated voltage, and provide stable power supply for the microphone to reduce the occurrence of faults.

Capsule Type: Condenser
Polar Pattern: Super cardioid
Frequency Response: 100Hz-15KHz
Sensitivity: >65dB 1V at 1Pa
Impedance: 420Ω
SPL: 125 dB, 1KHz at 1% T.H.D
Dynamic Range(Typical): 100dB, 1KHz at max. SPL
S/N Ratio: >52dB, 1KHz at 1Pa
Power Supply: MS-923/MS-933:24-52V DC
GF-923/GF-933:5V DC
Consumption: 5mA typical
Output Connector: Female 3-pin XLR
Dimensions (mm): 225(L)×42×87
Weight: About 355g
Color: MS-923 /GF-923: Black
MS-933 /GF-933: Champagne Gold

Frequency Response

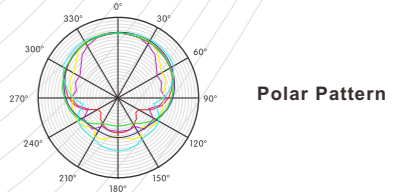
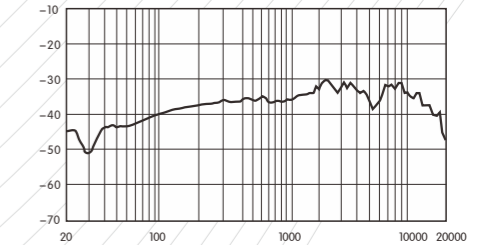

Polar Pattern

MS-923/GF-923
Detachable Square Microphone

MS-933/GF-933
Detachable Square Microphone

Relacart's detachable conference microphone bases can be used with detachable microphones at will, flexibly meeting different needs.

Detachables conference microphone bases collection

Wireless Microphone Bases



UD-280

Wireless Gooseneck Microphone Desk Stand



UD-280F

Wireless Gooseneck Microphone Desk Stand



UD-223

Wireless Gooseneck Microphone Desk Stand



UD-222

Wireless Gooseneck Microphone Desk Stand



UD-903

Wireless Gooseneck Microphone Desk Stand

Conference System Unit Bases



WDC-903C/D

Wireless Gooseneck Microphone Desk Stand



CS-NIC/D

Gooseneck Microphone Desk Stand



CS-302C/D

Gooseneck Microphone Desk Stand



CS-102BC/D

Gooseneck Microphone Desk Stand



CS-501BC/D

Gooseneck Microphone Desk Stand

Relacart's detachable conference microphone bases can be used with detachable microphones at will, flexibly meeting different needs.

Detachables Microphones collection

Detachables Gooseneck Microphones

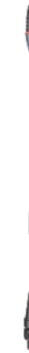

GF-101

Gooseneck Microphone



GF-301A

Gooseneck Microphone



GF-501

Gooseneck Microphone



GF-100

Gooseneck Microphone



GF-901

Gooseneck Microphone



GF-902

Gooseneck Microphone

Detachables Square Microphones

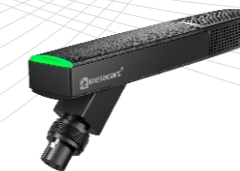

GF-923

Detachable Square Microphone



GF-933

Detachable Square Microphone

BM-110/111

BOUNDARY MICROPHONES



BM series condenser boundary microphone is designed for flush mounting into desktops or ceilings. Apply to televideo conferencing, recording or amplification of round table discussions and the microphones needs to be unobtrusive as possible. The microphones have excellent RF shielding effect, which makes the microphones absolutely insensitive to interference from wireless communication devices such as mobile phones. BM-110 provides a half-spherical polar pattern, making it ideal for large rooms. Due to its high sensitivity, even pick up the sound in far distance, output level won't appear large influence. The elastic bearing rings isolate the mechanical of the surface, thus the microphone can effectively isolate the mechanical noise. BM-111 half-cardioid polar pattern, which increases the gain-before-feedback and decreases the amount of diffuse ambience.

Key Features



Anti-Interference

- Excellent RF shielding effect, effectively avoiding RF interference.
- High gain-before-feedback



Hidden Installation

- Apply to fix or suspended ceiling installation
- Specially design for flush mounting into desktops or ceilings.



Clear Sound Quality

- Cardioid polar pattern, high-quality speech reproduction.
- Low-impedance balance audio output, the sound is smooth and clear.
- Equipped with auto-gain audio processing circuit, effectively avoiding the feedback.



Super Strong Directivity

- Cardioid polar pattern, increase gainbefore-feedback.
- Decrease the environment noise and feedback, guarantee the vocal clarity.



Delicate Workmanship

- Heavy die-case, stable and durable alloy shell and microphone.
- The button is equipped with elastic bearing rings, minimize the coupling of surface vibration to the surface.



Convenient Installation

- Accessories: elastic bearing rings
- Installation:
 - The installation hole(with elastic bearing ring)Ø24mm(15/16")
 - The installation hole(without elastic bearing ring)Ø20mm(13/16")
 - The maximum thickness of the desktop/ceiling 57mm(2.25)

Product Specification



BM-110
Boundary Microphone

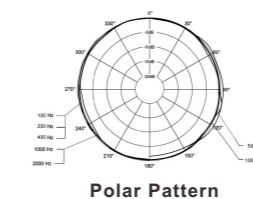

Polar Pattern

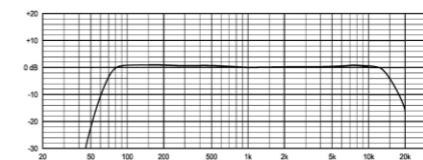

Frequency Response

Capsule:	Back of polarization electrostatic condenser type
Polar Pattern:	Hemispherical (omnidirectional)
Frequency Response:	80-18,000 Hz
Sensitivity:	18 mV/Pa = -34.4 dBV
Output Impedance:	< 200 Ω
Max. Input Sound Level:	106 dB [SPL @ 1% THD].
S/N:	68dB, 1 kHz @ 1Pa
Noise Voltage:	6.0 μV [A]
Phantom Supply:	DC12-52V
Current Consumption:	4mA (Typical)
Output Connector:	Built-in 3-pin XLRM
Weight:	95g (include nut and elastic bearing ring)
Dimension:	Length:74mm Width:20mm (steel pipe)39.5 mm(capsule ring)



BM-111
Boundary Microphone

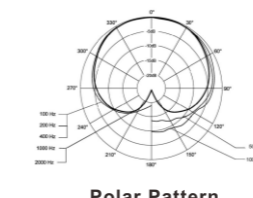

Polar Pattern

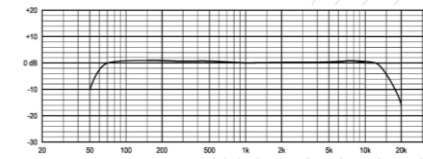

Frequency Response

Capsule:	Back of polarization electrostatic condenser type
Polar Pattern:	Hemispherical (unidirectional)
Frequency Response:	80-18,000 Hz
Sensitivity:	18 mV/Pa = -34.4 dBV
Output Impedance:	< 200 Ω
Max. Input Sound Level:	106 dB [SPL @ 1% THD].
S/N:	68dB, 1 kHz @ 1Pa
Noise Voltage:	6.0 μV [A]
Phantom Supply:	DC12-52V
Current Consumption:	4mA (Typical)
Output Connector:	Built-in 3-pin XLRM
Weight:	95g (include nut and elastic bearing ring)
Dimension:	Length:75 mm Width:20mm (steel pipe)39.5 mm(capsule ring)

IMIC-6 | DUAL CHANNEL TRUE DIVERSITY WIRELESS MICROPHONE SYSTEM



IMIC-6 is a true diversity dual-channel wireless microphone system developed by Relacart for educational applications. It features two XLR inputs for connecting additional wired microphones (with 48V phantom power), USB digital output, and specialized management software compatible with PC, smartphones, or tablets. It supports functions such as public address system input, alarm input, central control interface, microphone locking on charging base, feedback suppression, etc. Additionally, it comes with a page-turning laser pointer, smart charging base, and more, making it suitable for a wide range of applications including education, lectures, conferences, etc.

Key Features

Multiple audio outputs

- Adopt 6.3mm unbalanced output, XLR balanced output, USB digital audio output, it is convenient to connect various audio processing equipment.

Infrared pairing window extension design

- The IR pairing function can be extended with the infrared extension synchronizer EC-58. When the receiver is installed in the cabinet, this synchronizer can be used to extend the IR window to a position convenient for synchronization.

Practical function

- Connect to a PC or teaching tablet for audio input/output via USB. The page-turning control is also transmitted to the PC or tablet through this USB connection.
- Use the stereo AUX input of the RCA socket to connect LINE OUT audio equipment.
- Provide power to the charging base, allowing for charging of the transmitter and page-turning laser pointer. Up to 3 charging bases can be cascaded.
- Lock the transmitter and page-turning laser pointer in the charging base via remote control software.
- Remotely control the functional parameters of the receiver via the central control protocol.

Provide power to antennas

- The BNC connector of the receiver can be connected to passive antennas and active antennas, and it can provide power to the active antennas.

DSP audio processing algorithm

- Built-in high and low pass filters, parametric equalizer, feedback suppression, volume detection, audio matrix, volume control and other functions.

Alarm trigger input port

- When the alarm port receives a high-level signal, the alarm function is activated, automatically muting all output audio until the alarm state is cleared.

Public address system input

- For constant voltage power amplifier input, use the switch to select the input voltage level: 0V, 25V, 70V, 100V. The public address input also features a priority function. When an audio signal is input to the PA interface, other audio sources will be automatically muted. Once the public address audio signal ends, the mute will be canceled.

Product Specification



IMIC-6
Dual Channel Wireless Receiver

- EIA Standard Rack 1U metal chassis.
- Receiver equipped with exquisite LED display, can clearly display receiving channel, RF and AF signal.

Receiving Frequency Range:	521.25MHz ~ 936.85MHz
Receiving Method:	Superheterodyne
Image Rejection:	45dBm
RF Sensitivity:	When inputting 10dBu, S/N≥45dB
Squelch Adjustment:	Built-in setting parameters
Frequency Synchronization method:	Manual button setting
Digital Audio Output:	Supports Type-C, USB audio, Rj45
Power Supply Mode:	DC12V 1A
Dimensions (mm):	410 (W)×206 (D)×43 (H)
Net Weight:	1.9KG

T6
Wireless Transmitter



- An extremely compact wireless transmitter with a unique magnetic soft clip on the back, which can be clipped on your collar or attached to metal objects. Built-in 450mA lithium battery, bright OLED clearly displays the working status of the device, suitable for teaching, lectures, meetings, demonstrations and other occasions.

Carrier Frequency Range:	521.25MHz ~ 936.85MHz
Oscillation Mode:	PLL frequency synthesis
Transmit Power:	13.5dBm
Carrier Error:	0.005%
Harmonic Radiation:	-32dBm
Modulation Method:	FM
Max. Deviation:	±65KHz
Max. input level:	150mV
Frequency Setting:	Auto/Infrared
Power Supply Mode:	Built-in 3.7V 435mA lithium battery power supply
Normal Working Current:	100mA
Max. charging current:	300mA
Battery Life:	≥4 hours
Dimensions (mm):	32 (W)×13.5 (D)×67 (H)
Net Weight (g):	31.5

EC-6
Single Bay Charger



- Single Bay Charger suitable for the IMIC-6 series supports one-click locking function, which can prevent device loss after being turned on and easy to manage. It has two TYPE-C communication ports and a wiring terminal for external control signals, which can upload the equipment status to the central control system for centralized management.
- DC-5V provides a maximum charging current of 1A.
- Dimensions (mm): 86 (W)×86 (D)×60.2 (H)

WL-6
Page-turning laser pointer (green light)



- The laser pointer is suitable for the IMIC-6 series. It has an exquisite and lightweight appearance. It supports wireless control of page turning and laser pointing functions. It can be used in teaching, lectures, demonstrations, meetings and other occasions.

Power Supply:	Built-in lithium battery
Charging:	Dedicated charging stand or USB-C plug DC-5V-1A
Power Consumption:	Laser startup 0.66W (5V/132mA)
Standby:	500nA
Wireless control page turning distance:	10 meters
Dimensions (mm):	31 (W)×15.5 (D)×112.7 (H)

EC-6W
Single Bay Charger (Built-in page turning function receiver)



- Single Bay Charger suitable for the IMIC-6 series supports one-click locking function, which can prevent device loss after being turned on and easy to manage. It has two TYPE-C communication ports and a wiring terminal for external control signals, which can upload the equipment status to the central control system for centralized management.
- DC-5V provides a maximum charging current of 1A.
- Dimensions (mm): 86 (W)×86 (D)×60.2 (H)

EC-60C
External Synchronizer

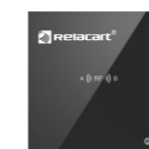

- The infrared extension synchronizer can provide a larger and better receiving effect in the required coverage area, and expand the working range and stability of the wireless system. As long as the receiver and the transmitter are aligned within a range of about 30CM can achieve the synchronization. After the synchronization is completed, the infrared extension synchronizer will make a "dee" sound.
- The EC-60C can be installed on the indoor wall.

Working Mode:	MCU control
Infrared Frequency:	32KHz
Power Supply:	DC 12V
Normal Working Current:	50mA
Size(mm):	85(W)×85(H)×43(D)
Weight:	65g

IMIC-6D | DUAL CHANNEL TRUE DIVERSITY WIRELESS MICROPHONE SYSTEM



IMIC-6D is a true diversity dual-channel wireless microphone system developed by Relacart for educational applications. It features two XLR inputs for connecting additional wired microphones (with 48V phantom power), Dante output, USB digital output, and specialized management software compatible with PC, smartphones, or tablets. It supports functions such as public address system input, alarm input, central control interface, microphone locking on charging base, feedback suppression, etc. Additionally, it comes with a page-turning laser pointer, smart charging base, and more, making it suitable for a wide range of applications including education, lectures, conferences, etc.

Key Features

Multiple audio outputs

- Adopt 6.3mm unbalanced output, XLR balanced output, Dante network audio output and USB digital audio output, it is convenient to connect various audio processing equipment.

Infrared pairing window extension design

- The IR pairing function can be extended with the infrared extension synchronizer EC-58. When the receiver is installed in the cabinet, this synchronizer can be used to extend the IR window to a position convenient for synchronization.

Practical function

- Connect to a PC or teaching tablet for audio input/output via USB. The page-turning control is also transmitted to the PC or tablet through this USB connection.
- Use the stereo AUX input of the RCA socket to connect LINE OUT audio equipment.
- Provide power to the charging base, allowing for charging of the transmitter and page-turning laser pointer. Up to 3 charging bases can be cascaded.
- Lock the transmitter and page-turning laser pointer in the charging base via remote control software.
- Remotely control the functional parameters of the receiver via the central control protocol.

Provide power to antennas

- The BNC connector of the receiver can be connected to passive antennas and active antennas, and it can provide power to the active antennas.

DSP audio processing algorithm

- Built-in high and low pass filters, parametric equalizer, feedback suppression, volume detection, audio matrix, volume control and other functions.

Alarm trigger input port

- When the alarm port receives a high-level signal, the alarm function is activated, automatically muting all output audio until the alarm state is cleared.

Public address system input

- For constant voltage power amplifier input, use the switch to select the input voltage level: 0V, 25V, 70V, 100V. The public address input also features a priority function. When an audio signal is input to the PA interface, other audio sources will be automatically muted. Once the public address audio signal ends, the mute will be canceled.

Product Specification



IMIC-6D
Dual Channel Wireless Receiver

- EIA Standard Rack 1U metal chassis.
- Receiver equipped with exquisite LED display, can clearly display receiving channel, RF and AF signal.

Receiving Frequency Range:	521.25MHz ~ 936.85MHz
Receiving Method:	Superheterodyne
Image Rejection:	45dBm
RF Sensitivity:	When inputting 10dBu, S/N≥45dB
Squelch Adjustment:	Built-in setting parameters
Frequency Synchronization method:	Manual button setting
Digital Audio Output:	Supports Type-C, USB audio, Rj45, DANTE audio
Power Supply Mode:	DC12V 1A
Dimensions (mm):	410 (W)×206 (D)×43 (H)
Net Weight:	1.9KG

T6
Wireless Transmitter



EC-6
Single Bay Charger



WL-6
Page-turning laser pointer (green light)



EC-6W
Single Bay Charger (Built-in page turning function receiver)



EC-60C
External Synchronizer



- An extremely compact wireless transmitter with a unique magnetic soft clip on the back, which can be clipped on your collar or attached to metal objects. Built-in 450mA lithium battery, bright OLED clearly displays the working status of the device, suitable for teaching, lectures, meetings, demonstrations and other occasions.

Carrier Frequency Range:	521.25MHz ~ 936.85MHz
Oscillation Mode:	PLL frequency synthesis
Transmit Power:	13.5dBm
Carrier Error:	0.005%
Harmonic Radiation:	-32dBm
Modulation Method:	FM
Max. Deviation:	±65KHz
Max. input level:	150mV
Frequency Setting:	Auto/Infrared
Power Supply Mode:	Built-in 3.7V 435mA lithium battery power supply
Normal Working Current:	100mA
Max. charging current:	300mA
Battery Life:	≥4 hours
Dimensions (mm):	32 (W)×13.5 (D)×67 (H)
Net Weight (g):	31.5

- Single Bay Charger suitable for the IMIC-6 series supports one-click locking function, which can prevent device loss after being turned on and easy to manage. It has two TYPE-C communication ports and a wiring terminal for external control signals, which can upload the equipment status to the central control system for centralized management.
- DC-5V provides a maximum charging current of 1A.
- Dimensions (mm): 86 (W)×86 (D)×60.2 (H)

- The laser pointer is suitable for the IMIC-6 series. It has an exquisite and lightweight appearance. It supports wireless control of page turning and laser pointing functions. It can be used in teaching, lectures, demonstrations, meetings and other occasions.

Power Supply:	Built-in lithium battery
Charging:	Dedicated charging stand or USB-C plug DC-5V-1A
Power Consumption:	Laser startup 0.66W (5V/132mA)
Standby:	500nA
Wireless control page turning distance:	10 meters
Dimensions (mm):	31 (W)×15.5 (D)×112.7 (H)

- Single Bay Charger suitable for the IMIC-6 series supports one-click locking function, which can prevent device loss after being turned on and easy to manage. It has two TYPE-C communication ports and a wiring terminal for external control signals, which can upload the equipment status to the central control system for centralized management.
- DC-5V provides a maximum charging current of 1A.
- Dimensions (mm): 86 (W)×86 (D)×60.2 (H)

- The infrared extension synchronizer can provide a larger and better receiving effect in the required coverage area, and expand the working range and stability of the wireless system. As long as the receiver and the transmitter are aligned within a range of about 30CM can achieve the synchronization. After the synchronization is completed, the infrared extension synchronizer will make a "dee" sound.
- The EC-60C can be installed on the indoor wall.

Working Mode:	MCU control
Infrared Frequency:	32KHz
Power Supply:	DC 12V
Normal Working Current:	50mA
Size(mm):	85(W)×85(H)×43(D)
Weight:	65g

TM-500

DUAL CHANNEL TRUE DIVERSITY
WIRELESS MICROPHONE SYSTEM



TM-500 is a true diversity wireless receiver developed by Relacart independently. It can be used with external frequency controller that can synchronize the microphone automatically, and it can be connected to the central controller, and has returning pages and cascade function.

Product Specification



TM-500
Dual Channel Wireless Receiver

- EIA Standard Rack 1U metal chassis.
- Receiver equipped with exquisite LED display, can clearly display receiving channel, RF and AF signal.

Receive Bandwidth:	521.25MHz ~ 936.85MHz
Receiving Method:	FM super heterodyne true diversity reception
RF Sensitivity:	5dBv, S/N≥60 dB at 25KHz deviation
Squelch Adjustment:	Set
Frequency Synchronization Method:	IR Sync
Maximum Output level:	Maximum output + 11dBV
Output Level Adjustment Range:	Set
Power Supply:	DC12V / 1A
Normal Working Current:	DV12V, 330mA
Dimensions (mm):	410 (W) × 206 (D) × 43 (H)
Net Weight:	1.8kg

Key Features

AFS(Automatic Frequency Selection)

- With "AFS" automatic frequency search function, according to the preset frequency to scan and calculate the interference-free working channel quickly and accurately.

Reliable Signal

- The BNC antenna jack can be connected to coaxial antennas and extended antennas, and provides antenna voltage, supports connection to the Relacart antenna distribution system, Extend multiple devices and enhance the receiving distance and improve the signal stability.

Anti-Interference

- The antenna diversity FM superheterodyne reception is adopted to ensure the stability of the received RF signal and the receiver's own anti-interference; the operating frequency range is 521MHz ~ 938MHz according to the radio wave control laws and regulations of various countries.

IR Infrared

- With [IR] infrared automatic synchronization frequency function, the transmitter's infrared window facing the infrared window of the receiver and press the "SYNC" button. The transmitter is automatically and accurately synchronized to the receiver's operating frequency.

Intelligent Design

- The receiver is equipped with LED segment displays, which can clearly display receiver information, such as channel, RF and AF signals.
- Applicable to schools and offices. It has stable function, long receiving distance and easy installation.
- Compliant with RS-485 communication protocol

Channel Group Mode

- 128MHz wide-band transmitter, four receivers in different frequency bands can be used interchangeably, which greatly facilitates engineering debugging and management.
- Use the channel group mode, and there are 50 channel groups in each frequency band for user selection.



TM-5H
Pen-type Microphone

- TM-5H handheld microphone is novel in appearance and small in size. Its circuit adopts advanced phase-locked technology, with built-in removable lithium battery, USB-TYPE-C charging interface and laser pen. Low power consumption, continuous working time of one charge ≥ 8 hours. It can be equipped with a wireless charging station certified by Qi, and can also realize wireless charging.

RF Carrier Range:	521.25MHz~938.85MHz
Frequency Stability:	±0.005%
Operating Range (environment dependent):	50m
Companding:	Relacart's classic audio companding circuit
Audio Frequency Response:	50Hz~18KHz/±3dB
Dynamic Range:	>100dB
S/N Ratio(A-Weighted):	>100dB
Total Harmonic Distortion:	<0.6%@1KHz
Operating Temperature Range:	-10°C~+50°C

ACCESSORIES

Product Specification



RC-12Li
Charging Station

Charging box Specification

Charging Voltage And Current:	5V/800mA
Maximum Power Consumption:	11A/65W
Number of Rechargeable Batteries:	12
Charging Display:	4-segment digital light
Power Supply:	100-240VAC, 50/60Hz.
Size(mm) :	488(W)×133(H)×190 (D)
Weight:	3.2kg

Battery Specification

Name:	Li-ion Polymer Battery
Model:	BP-10Li(545575)
Rated Capacity:	2900mAh/10.73Wh
Rated Voltage:	3.7V
Limited Charge Voltage:	4.2V
Measurement(mm):	85(W)×70(D)×9.5 (H)
Weight:	70g

RC-12Li is a charging box made of iron plate metal. It is durable, exquisite and beautiful. It can charge 12 pieces of BP-10Li lithium-ion polymer batteries at the same time. The 4-segment digital light shows the charging status. It has over voltage, over current circuit protection, and high temperature to escort battery charging.

Key Features

- It can charge 12 pieces BP-10Li lithium-ion polymer batteries at the same time, the maximum charging current is 800mA, and the BP-10Li battery can be fully charged in 5 hours.
- The 4-segment digital light shows the charging status, the digital light flashes rollingly when charging, and the 4-segment digital light is always on when fully charged.
- Adopt separate charging scheme, each battery has a separate charging management circuit
- Built-in self-recovery fuse, when the current of the charging circuit is too large, the self-recovery fuse will be disconnected to protect the circuit and the battery from damage. When the current of the circuit is normal, the self-recovery fuse returns to normal, and the charging circuit can work and charge normally.
- It has detection and protection circuits such as over voltage, over current, overcharge, and high temperature to protect the battery from charging safely.
- The charging box can be placed on the desktop or installed in the cabinet, which is convenient for installation and management.

ACCESSORIES

Product Specification



RC-24Li
Charging Station

Charging box Specification

Charging Voltage And Current:	5V/800mA
Maximum Power Consumption:	11A/65W
Number of Rechargeable Batteries:	24
Charging Display:	4-segment digital light
Power Supply:	100-240VAC, 50/60Hz.
Measurement(mm):	540(W)×400(D)×146 (H)
Weight:	7.5kg

Battery Specification

Name:	Li-ion Polymer Battery
Model:	BP-10Li(545575)
Rated Capacity:	2900mAh/10.73Wh
Rated Voltage:	3.7V
Limited Charge Voltage:	4.2V
Measurement(mm):	85(W)×70(D)×9.5 (H)
Weight:	70g

RC-24Li is a charging box made of iron plate metal. It is sturdy, durable and exquisite. It can charge 24 pcs of BP-10Li lithium-ion polymer batteries at the same time. The 4-segment digital light shows the charging status. It has over voltage, over current circuit protection, high-temperature detection and protection circuit to protect battery charging.

Key Features

- It can charge 24 BP-10Li lithium ion polymer batteries at the same time the maximum charging current is 800mA and the completely discharged BP-10Li battery can be fully charged within 5 hours.
- The 4-segment digital light shows the charging status the digital light scrolls and flashes while charging, and the 4-segment digital light is on when it is fully charged.
- Adopt a separate charging scheme each battery has a separate charging management circuit, and a problem with one charging circuit will not affect the other charging batteries.
- Built-in self-recovery fuse, when the current of the charging circuit is too large, the self-recovery fuse will be disconnected to protect the circuit and battery from damage. When the current of the circuit is normal the self-recovery fuse returns to normal and the charging circuit can be charged in normal operation.
- It has detection and protection circuits for over voltage, over current overcharge, and high temperature to protect the battery from being charged safely. The charging box can be placed on the desktop or installed in the cabinet to facilitate installation and management.

ACCESSORIES

Product Specification



EXP-124 Conference System Expansion Power Supply

- It is used to compensate the voltage attenuation caused by too long cable of the conference system, and is suitable for the conference system with 24V power supply.

Input Voltage:	AC220V, 50Hz
Output Voltage:	24V
Max:Output Power	72W
Input Expansion Connector:	9P-Pin aviation XLRM X1
Output Expansion Connector	9P-Pin aviation XLRM X1
Number of Microphones Supported :	15
Weight:	686g



EXP-124W Technical Specifications

Model:	EXP-124W
Power supply(AC):	110-240V, 50/60Hz
Output voltage:	24V
Maximum power output:	72W
Input/Output interface:	Network cable port
Number of Microphones Supported :	15
Dimension (mm):	220(L)×140(W)×48(H)
Weight:	About 950g



BP-10Li Li-ion Polymer Battery

- Compatible model:
WDC-903C/D
WDC-923C/D
WDC-933C/D

Model:	BP-10Li(545575)
Rated Capacity:	2900mAh/10.73Wh
Rated Voltage:	3.7V
Limited Charge	4.2V
Voltage:	
Measurement(mm):	85(W) × 70(D) × 9.5 (H)
Weight:	70g

ACCESSORIES

Product Specification



P-24V01 Adaptor

- AC 24V power supply, power supply for p-48v1s.

Input Voltage:	220V AC
Output Voltage:	24VAC
Current:	100mA
Weight:	276g



MC9-Pins Connecting Cable for conference system

- 9 pin cable for CS100/101/301/300 conference system main controller and microphone connection

Length available

MC9-15-1	1.5M×1M
MC9-15-10	1.5M×10M
MC9-15-20	1.5M×20M
MC9-15-30	1.5M×30M
MC9-15-40	1.5M×40M



RC-809HD Camera

- 4 million pixels, 1 / 2.5 inch Exmor CMOS sensor Full HD multi-format output (DVI-I / HDMI / 3G-SDI) 20x zoom
- Wide-range fast pan / tilt head, precise positioning at 355 degrees horizontally
- Multifunctional infrared remote control, all functions of the camera can be completed by remote control
- Support RS-232C and RS-422 / 485 control
- Compatible with SONY VISCA protocol and PELCO P / D protocol
- Image flip support (for desktop and ceiling installation)
- Support self-upgrade program through RS-232C serial port

MIXX 16 | DIGITAL MIXER



MIXX16 Digital Mixer is a 16 inputs and 8 output digital wireless control mixer, is a new mixer through the tablet computer application control, can support all iOS, Windows 8 tablet and Android tablet. Using Wi-Fi to connect, anywhere in the wireless network within the scope of control. With 16 channels of broadcasting quality microphone amplifier (including 4 modular jack), main and aux outs. Adopt high performance 40 bit floating-point digital signal processor, 24 bit AD/DA converter. Built-in effects processor, compression and limiter, gate plug-ins, parametric equalizer. Wireless control mode makes you can walk between the stage and the crowd. It is 16-channel digital mixer that with the iPad and tablet computer touch.

Product Specification



MIXX 16
Digital Mixer

Sample Rate:	24bit, 48kHz
Frequency Respond:	20 Hz to 20 kHz +0/-1 dB
System Delay:	1.5 ms
T.H.D.:	<0.005%
Noise-Mic Input to Main Output:	-72 dBV Single channel-Max fader(A weighted) -90dBV Single channel-Min fader(A weighted)
Input Crosstalk (adjacent channel):	<-120 dB @1 kHz
S/N:	93dB Single channel-Max fader(A weighted)
Dynamic Range:	110dB Single channel-Max fader(A weighted)
CMR:	>70 dB @1 kHz
Input Impedance:	30 kΩ(1/4")
Gain:	0 to 60 dB (XLR) -20 to 40 dB(1/4")
Output Impedance:	600Ω(XLR Balance)
Max Output Level:	+21 dBu(XLR Balance)
Power Supply:	DC 12V-15V(3.5A)
Dimension(mm):	359(L)×85.5(H)×411(D)
Weight:	Approximately 4.2kg

Key Features

Practical Function

- Intuitive touch control, covering almost all the major mixing functions.
- The mixer interface can be adjusted for each channel control, including solo, mute, audio-visual, fader, you can see the full level meter.
- Tons of built-in processing. Choice of powerful, touch-sensitive plug-ins, 4-band EQ, gate and compression on inputs, 31-band GEQ and com/limiter on outputs, global reverb and delay.

Flexible Configuration

- Each channel can edit their own names and icons for easy identification, the icon can be imported from a picture library.
- Power and 48V phantom power switches and LEDs round out the mixer.
- Seamless wired to wireless mixing, turn the room from anywhere, get on stage to ring out monitors, personal monitor mixing with access control ability.

Reverberation sharing

- Ultralow-noise, high-headroom design.
- Global shared reverberation (reverse) and delay effect (delay).

DSP DSP Audio Effector

- The channel interface can control a powerful DSP effector. The input channel includes four sections of PEQ, high pass filtering, compression and threshold. The main channel and auxiliary channel include 31 sections of graphical EQ and limiter. The effector channel includes reverberation and delay.

Software Interface Instructions

- ① Channels
- ② AUX
- ③ Phantom Power
- ④ Effect
- ⑤ Channel Name
- ⑥ Compression and Gate
- ⑦ Matrix
- ⑧ Master output

INPUT EQ

- ① EQ Setting
- ② EQ Adjustable
- ③ HPF and LPF adjustable



MIXX 12 | DIGITAL MIXER WITH DANTE INTERFACE



MIXX12 Digital Mixer is a 12 inputs and 6 outputs digital wireless control mixer, is a new mixer through the tablet computer application control, can support all iOS, Windows 8 tablet and Android tablet. Using Wi-Fi to connect, anywhere in the wireless network within the scope of control. With 12inputs/12 channels of broadcast quality microphone amplifier,6 outputs (two main and 4 aux outs). Adopt high performance 40 bit floating-point digital signal processor,24 bit AD/DA converter. Built-in effects processor, compression and limiter, gate plug-ins,parametric equalizer. Wireless control mode makes you can walk between the stage and the crowd. It is 12-channel digital mixer that with the iPad and tablet computer touch. Equip with DANTE card.

Product Specification



MIXX 12
Digital Mixer

Sample Rate:	24bit,48kHz
Frequency Respond:	20 Hz to 20 kHz +0/-1 dB
System Delay:	1.5 ms
T.H.D.:	<0.005%
Noise-Mic Input to Main Output:	-72 dBV Single channel-Max fader(A weighted) -90dBV Single channel-Min fader(A weighted)
Input Crosstalk (adjacent channel):	<-120 dB @1 kHz
S/N:	93dB One channel and main fader at unity(A-weighted)
Dynamic Range:	110dB 93dB One channel and main fader at unity(A-weighted)
CMR:	>70 dB @1 kHz
Input Impedance:	3.3kΩ (XLR Balance) ;30 kΩ (1/4")
Gain:	0 to 60 dB (XLR)
Output Impedance:	600Ω(XLR Balance)
Max Output Level:	+21 dBu(XLR Balance)
Power Supply:	DC 12V-15V(3.5A)
Dimension(mm):	448(L)×132(H)×191(D)
Weight:	Approximately 4.2kg

Key Features

Practical Function

- Intuitive touch control, covering almost all the major mixing functions.
- The mixer interface can be adjusted for each channel control, including solo, mute, audio-visual, fader, you can see the full level meter.
- Tons of built-in processing. Choice of powerful, touch-sensitive plug-ins, 4-band EQ, gate and compression on inputs, 31-band GEQ and com/limiter on outputs, global reverb and delay.

Flexible Configuration

- Each channel can edit their own name and icon for easy identification, the icon can be imported from a picture library.
- Power and 48V phantom power switches and LEDs round out the mixer.
- Seamless wired to wireless mixing, turn the room from anywhere, get on stage to ring out monitors, personal monitor mixing with access control ability.

Flexible Expansion

- Use up to 10 iOS devices simultaneously.
- Standard Ethernet or Dante™ digital soundcard available, can connect the MIXX12 to any Dante™ device.

Clear Sound Quality

- Ultra low-noise, high-headroom design.

Dante™ upgrade card

Dante-equipped models enable multi-channel audio networking over Ethernet. Standard Ethernet or Dante™ digital networked audio configurations available. Ethernet digital audio of Multi channel, with 24-Bit depth and 48 KHz sample rate. Plug and play networking function,with automatic device discovery function and system configuration. Dante upgrade card available for standard Ethernet models. Dante virtual sound card license included to connect a computer to a Dante network for recording, playback and Internet calling between Dante-equipped devices(download Dante virtual sound card at audinate.com)

EZD.Mi1/Mi2/Mi4 | UHF TRUE DIVERSITY DIGITAL WIRELESS MICROPHONE SYSTEM



The EZD.Mi Series is a newly upgraded high-performance wireless audio solution from Relacart. Featuring a sleek design and plug-and-play operation, it significantly reduces complexity for users, making it suitable for diverse application scenarios. Built with Relacart Digital Wireless Technology and multiple diversity techniques, the system ensures stable signal transmission and reliable performance, eliminating concerns over signal loss. Equipped with a high-performance processing chip and proprietary digital algorithms, the system delivers a wide frequency response of 30Hz–20kHz, accurately reproducing vocal details with clarity and fidelity. It achieves an outstanding signal-to-noise ratio of >100dB and total harmonic distortion of <0.1% @1kHz, ensuring clean, distortion-free audio output. Ideal for applications ranging from home entertainment and personal performances to commercial events and conference settings.

Key Features

User-Friendly Operation

- The system features an intuitive operation logic, allowing users to quickly set up and use it without the need for professional technical assistance. This significantly reduces the complexity of system configuration while catering to needs such as home entertainment and personal performances.

High-Definition Audio

- Combining core hardware with anti-interference technology, the system delivers pure and accurate sound reproduction. Equipped with a high-performance processing chip and Relacart's proprietary anti-interference technology, it covers a wide frequency response range of 30Hz–20kHz. This ensures precise capture of vocal details across all ranges, from deep resonances to high-pitched nuances, reproducing transparent and crystal-clear high-fidelity audio.

Strong Anti-Interference Capability

- Utilizing Relacart's digital wireless technology integrated with diversity and anti-interference mechanisms, the system enhances signal stability at the transmission level. It ensures continuous, uninterrupted audio even in complex environments, providing a reliable experience for prolonged events and meetings.

High Compatibility

- With an ultra-wide bandwidth of 64MHz—broader than most comparable products on the market—the system supports simultaneous operation of up to 24 compatible units within this spectrum. This enables efficient utilization of frequency resources and provides ample frequency options even for large-scale events, making it easier to avoid interference.

Stability and Reliability

- The system offers an effective operating range of up to 100 meters in open environments. Even in large venues such as conference halls or outdoor performance spaces, it guarantees stable audio transmission without quality degradation or signal loss over long distances.

Clear Visual Indicators

- The receiver is equipped with multi-color indicators that correspond precisely to the screen colors of the paired transmitters. In multi-device setups or dimly lit environments, users can intuitively and quickly identify and match channel devices, significantly improving operational convenience.

Product Specification



EZD.Mi1
Single Channel Wireless Receiver



EZD.Mi2
Dual Channel Wireless Receiver



EZD.Mi4
Quad Channel Wireless Receiver

- The receiver offers a 64MHz bandwidth—wider than most comparable products on the market—and supports simultaneous operation of up to 24 compatible systems within this range. This enables efficient spectrum utilization and stable communication, with an effective operating range of up to 100 meters in open environments.
- Compatible with handheld, headset, and lapel microphones, the system adapts to various wireless needs.

Chassis Specification:	1U Half-Rack(EZD.Mi1) EIA Standard 1U(EZD.Mi2/Mi4)
Reception Method:	True Diversity Single-Channel Reception(EZD.Mi1) True Diversity Dual-Channel Reception(EZD.Mi2) True Diversity Quad-Channel Reception(EZD.Mi4)
Frequency Stability:	±0.005%
Carrier Frequency Range:	470MHz–936MHz
Operating Range:	100 meters (open area)
Modulation Method:	D-QPSK
Bandwidth:	64MHz (region-dependent)
Overall S/N Ratio:	>100dB
Total Harmonic Distortion (T.H.D.):	<0.1% @1kHz
Frequency Response:	30Hz–20kHz ±1dB
Operating Temperature Range:	-10°C to 50°C
Power Supply:	DC 12V/1A
Antenna Interface:	Dual BNC, Supports +12V/150mA Output
Audio Output Interfaces:	6.3mm Unbalanced Audio Output, 2× XLR Balanced Audio Output
Dimensions (mm)EZD.Mi1:	205 (L) × 206 (W) × 43 (H)
Dimensions (mm)EZD.Mi2/Mi4:	410 (L) × 206 (W) × 43 (H)
Weight(Approx):	EZD.Mi1:1kg EZD.Mi2:2kg EZD.Mi4:2kg



EZD.H9
Wireless Handheld Microphone

- The EZD.H9 features a modern and stylish design, constructed with durable alloy for long-lasting use. Compatible with the EZD.Mi Series Digital Wireless Microphone System, it integrates a high-quality dynamic microphone capsule with full digital transmission algorithms to deliver rich, clear audio.
- Powered by AA batteries and designed with an energy-efficient circuit, it offers an extended battery life of 8–10 hours. Ideal for a wide range of scenarios, including home entertainment, personal performances, commercial events, and conference environments.

Carrier Frequency Range:	470MHz ~ 936MHz
Harmonic Radiation:	>45dB below carrier
Bandwidth:	128MHz (region-dependent)
Modulation:	D-QPSK
Occupied Bandwidth:	250kHz
Transducer Type:	Dynamic
RF Output Power:	+13dBm
Battery:	2×AA
Current Consumption:	150mA (typical)
Battery Life:	Approx. 12 hours (alkaline)
Dimensions (mm):	Ø55 × 269 (L)

EZD.B8
Wireless Bodypack Transmitter



- The EZD.B8 is a rugged and durable bodypack transmitter designed for reliable performance. Its compact and lightweight construction allows comfortable waist-worn use or discreet placement under clothing. Compatible with the EZD.Mi Series Digital Wireless Microphone System, it features a 3.5mm external microphone interface for connecting Relacart LM-P01 lapel microphones or HM-P06 headset microphones.
- Powered by two AA batteries with an energy-efficient design, it delivers 8–10 hours of continuous operation. Suitable for diverse scenarios including home entertainment, personal performances, commercial events, and conference environments.

Carrier Frequency Range:	470MHz ~ 936MHz
Harmonic Radiation:	More than 45dB below carrier
Bandwidth:	128MHz (region-dependent)
Modulation:	D-QPSK
Occupied Bandwidth:	250kHz
Audio Input:	3.5mm external microphone interface
RF Output Power:	+13dBm
Battery:	2×AA
Current Consumption:	150mA (typical)
Battery Life:	Approx. 12 hours (alkaline)
Dimensions (mm):	198 (H) × 52.5 (W) × 28 (D)

EZ.Mi4

QUAD-CHANNEL TRUE DIVERSITY WIRELESS MICROPHONE SYSTEM



EZ.Mi4 is a highly cost-effective four channel UHF wireless microphone system. The main feature is that the transmitter uses a simple and bright LCD display to display the current channel and battery power, and the receiver also uses a high brightness LED display to display the corresponding product information. Infrared automatic frequency matching and lock the selected frequency. The receiver adopts a standard 1 U all metal chassis it supports volume adjustment, channel adjustment and other functions. The effective working distance is about 60-80 meters. Suitable for commercial performance, schools, government enterprise projects, personal and family entertainment applications.

Key Features

UHF UHF Transmission Band

- UHF, one to two wireless transmission, provides high fidelity audio source.

IR Infrared

- IR infrared automatically aligns frequency and locks corresponding frequency points.

Multiple Operating Frequency Points

- Multiple switchable frequency points for operation without environmental interference.

DSP DSP Digital Audio Companding

- DSP digital audio companding adopts 48KHz audio sampling rate to minimize the noise in the wireless transmission system.

Widely Applicable

- It is widely used in commercial performance, schools, government enterprise projects, personal and family entertainment applications.

Information Display

- LCD and LED display screen are used to display corresponding product information.

Product Specification



EZ.Mi4

Quad Channel Wireless Receiver

Carrier frequency range:	470MHz-960MHz
Frequency stability:	0.005%
Effective working distance (ideal environment):	≥ 60m
Audio companding:	DSP digital audio companding
Audio sampling rate:	48KHz
Audio frequency response:	50Hz - 18000Hz ± 3dB
Dynamic range:	92 dB
Signal to noise ratio :	105 dB(A-weighted)
Total harmonic distortion:	≤ 0.8% @ 1KHz
Operating temperature range:	- 10 °C~+50 °C
Receiving mode:	Four channels, superheterodyne true diversity receiving
Image rejection:	45dBm
RF sensitivity:	S/N ≥ 45dB when 10dBu is input
Silence adjustment:	built-in setting parameters
Frequency synchronization mode:	infrared SYNC
Maximum output level:	LINE: 0.5Vpp
Output level adjustment range:	6-level adjustable, attenuating adjustment, step by step every 3dB;
Power supply mode:	DC 12V/1A
Normal working current:	DC 12V: 380mA
Dimensions (mm):	410(W)×212(D)×43(H)
Weight(without battery):	Approximately 1.95kg



EZ.H8

Wireless Handheld Microphone

- The pipe body of EZ.H8 is made of high-strength plastic, which is not only light and saves energy, but also eliminates rust and other issues, greatly improving its service life..

RF Carrier Frequency Range:	470MHz-960MHz
Oscillation Mode:	PLL frequency synthesis
Transmission Power:	13.5dBm
Carrier Deviation:	0.005%
Harmonic Emissions:	-32dBm
Modulation Mode:	FSK
Nominal/maximum Frequency Deviation:	±65KHz
Maximum Input Level:	250mV
Input Impedance:	2.2KΩ
Frequency Set-up:	IR SYNC
Power Requirements:	AA1.5V x2
Current Consumption:	120mA
Battery Life:	≥10 Hours
Dimension (mm):	59.5(Φ) x 236(L)
Weight:	About 246g (w/o battery)

EZ.B8

Wireless Bodypack Transmitter



- The EZ.B8 is a rugged and durable bodypack transmitter designed for reliable performance. Its compact and lightweight construction allows comfortable waist-worn use or discreet placement under clothing. Compatible with the EZ.Mi Series Digital Wireless Microphone System, it features a 3.5mm external microphone interface for connecting Relacart LM-P01 lapel microphones or HM-P06 headset microphones.
- Powered by two AA batteries with an energy-efficient design, it delivers 8-10 hours of continuous operation. Suitable for diverse scenarios including home entertainment, personal performances, commercial events, and conference environments.

RF Carrier Frequency Range:	470MHz-960MHz
Oscillation Mode:	PLL frequency synthesis
Transmission Power:	13.5dBm
Carrier Error:	0.005%
Harmonic Radiation:	-32dBm
Modulation Mode:	FSK
Nominal/maximum Frequency Deviation :	± 65KHz
Maximum Input Level:	250mV
Input Impedance:	Mic 2.2KΩ , Line 4.7 KΩ
Frequency Setting:	Infrared synchronization
Input Gain Adjustment Range:	4-level adjustable setting, every 3dB step
Power Supply Mode:	AA 1.5Vx2
Normal Working Current:	AA battery power supply: 120mA
Battery Life:	>8 hours
Boundary Dimension(mm):	198(H) x52.5(W)x28(D)
Weight (without battery):	About 50g

EZ.Mi1/Mi2

SINGLE/DUAL-CHANNEL TRUE DIVERSITY WIRELESS MICROPHONE SYSTEM

EZ TRUE DIVERSITY WIRELESS MICROPHONE SYSTEM



EZ. Mi1 is a highly cost-effective single channel UHF wireless microphone system. EZ. Mi2 is a highly cost-effective dual channel UHF wireless microphone system. The main feature is that the transmitter uses a simple and bright LCD display to display the current channel and battery power, and the receiver also uses a high brightness LED display to display the corresponding product information. Infrared automatic frequency matching and lock the selected frequency. The receiver adopts a standard 1 U chassis, all metal construction. The effective working distance is about 60-80 meters. Suitable for commercial performance, schools, government enterprise projects, personal and family entertainment applications.

Key Features

UHF UHF Transmission Band

- UHF, one to two wireless transmission, provides high fidelity audio source.

IR Infrared

- IR infrared automatically aligns frequency and locks corresponding frequency points.

Multiple Operating Frequency Points

- Multiple switchable frequency points for operation without environmental interference.

DSP DSP Digital Audio Companding

- DSP digital audio companding adopts 48KHz audio sampling rate to minimize the noise in the wireless transmission system.

Widely Applicable

- It is widely used in commercial performance, schools, government enterprise projects, personal and family entertainment applications.

Information Display

- LCD and LED display screen are used to display corresponding product information.

Product Specification



EZ.Mi1
Single Channel Wireless Receiver



EZ.Mi2
Dual Channel Wireless Receiver

Chassis Specification:	1U Half-Rack(EZ.Mi1) EIA Standard 1U(EZ.Mi2)
Reception Method:	True Diversity Single-Channel Reception(EZ.Mi1) True Diversity Dual-Channel Reception(EZ.Mi2)
Frequency Stability:	±0.005%
Carrier Frequency Range:	470MHz-936MHz
Effective working distance (ideal environment):	≥ 60m
Audio companding:	DSP digital audio companding
Audio sampling rate:	48KHz
Audio frequency response:	50Hz - 18000Hz ± 3dB;
Dynamic range:	92 dB
Signal to noise ratio :	105 dB(A-weighted)
Total harmonic distortion:	≤ 0.8% @ 1KHz
Operating temperature range:	- 10 °C~+50 °C
Image rejection:	45dBm
RF sensitivity:	S/N ≥ 45dB when 10dBu is input;
Silence adjustment:	Built-in setting parameters
Frequency synchronization mode:	Infrared SYNC
Maximum output level:	LINE: 0.5Vpp;
Output level adjustment range:	6-level adjustable, attenuating adjustment, step by step every 3dB;
Power supply mode:	DC 12V/1A
Normal working current:	DC 12V: 250mA
Dimensions (mm)EZ.Mi1:	205 (L) × 209 (W) × 43 (H)
Dimensions (mm)EZ.Mi2:	410 (L) × 212 (W) × 43 (H)
Weight(Approx):	EZ.Mi1:990g EZ.Mi2:1.76kg



EZ.H8
Wireless Handheld Microphone

- The pipe body of EZ.H8 is made of high-strength plastic, which is not only light and saves energy, but also eliminates rust and other issues, greatly improving its service life.

RF Carrier Frequency Range:	470MHz-960MHz
Oscillation Mode:	PLL frequency synthesis
Transmission Power:	13.5dBm
Carrier Deviation:	0.005%
Harmonic Emissions:	-32dBm
Modulation Mode:	FSK
Nominal/maximum Frequency Deviation:	±65KHz
Maximum Input Level:	250mV
Input Impedance:	2.2KΩ
Frequency Set-up:	IR SYNC
Power Requirements:	AA1.5V x2
Current Consumption:	120mA
Battery Life:	≥10 Hours
Dimension (mm):	59.5(Φ) x 236(L)
Weight:	About 246g (w/o battery)



EZ.B8
Wireless Bodypack Transmitter

- The EZ.B8 is a rugged and durable bodypack transmitter designed for reliable performance. Its compact and lightweight construction allows comfortable waist-worn use or discreet placement under clothing. Compatible with the EZ.Mi Series Digital Wireless Microphone System, it features a 3.5mm external microphone interface for connecting Relacart LM-P01 lapel microphones or HM-P06 headset microphones.
- Powered by two AA batteries with an energy-efficient design, it delivers 8-10 hours of continuous operation. Suitable for diverse scenarios including home entertainment, personal performances, commercial events, and conference environments.

RF Carrier Frequency Range:	470MHz-960MHz
Oscillation Mode:	PLL frequency synthesis
Transmission Power:	13.5dBm
Carrier Error:	0.005%
Harmonic Radiation:	-32dBm
Modulation Mode:	FSK
Nominal/maximum Frequency Deviation :	± 65KHz
Maximum Input Level:	250mV
Input Impedance:	Mic 2.2KΩ , Line 4.7 KΩ
Frequency Setting:	Infrared synchronization
Input Gain Adjustment Range:	4-level adjustable setting, every 3dB step
Power Supply Mode:	AA 1.5Vx2
Normal Working Current:	AA battery power supply: 120mA
Battery Life:	>8 hours
Boundary Dimension(mm):	198(H) x52.5(W)x28(D)
Weight (without battery):	About 50g

Mi3

2.4G DUAL CHANNEL WIRELESS MICROPHONE SYSTEM

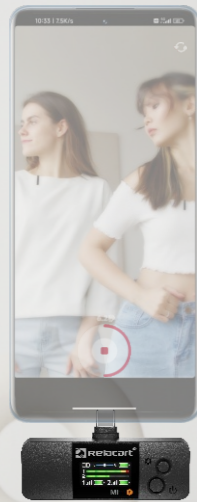

MIPASSPORT Mi.3 is a new generation of portable wireless microphone launched by Relacart. It is smaller and lighter than the previous generation. The innovative wearing method and hidden pickup can achieve a better hidden effect. Video shooting can well hide the existence of the microphone. And it's more comfortable to use. MIPASSPORT Mi.3 inherits and optimizes the sound quality of the previous generation, with wider bandwidth, lower noise, and sound details are well displayed. The receiver supports digital and analog output, and the digital output can be replaced with Type C or Lightning adapter, which is well compatible with different mobile phones, cameras, PCs and other devices. The standard charging case of MIPASSPORT Mi.3 extends the battery life to more than 20 hours. The charging case is well compatible with charging and storage, and at the same time, it can be opened and picked up for use and no need frequency pairing. It is suitable for scenarios such as interviews, live streaming, video shooting, or business presentations.

Key Features

- TFT Multifunctional TFT Display**
 - The receiver adopts a TFT multi-function display, which can display the current battery status, current RF and AF status, etc.
- Detachable Adapter**
 - Mi.3 wireless receiver adopts detachable adapter design, and it is equipped with a camera shoe-mount adapter lightning and Type-C connector. You only need to select the corresponding adapter and equipment to plug and play, no need to connect additional cable.
- Hidden Sound Hole Design**
 - With the hidden sound pickup hole design, most of the subdivisions of the transmitter can be hidden in the clothing to reduce the exposure of the machine to the lens, making every shot of your shooting more concise and clean.

- 2.4G ISM Global Unlimited Transmission Frequency Band**
 - Adopt ISM Global Unlimited transmission frequency band for audio transmission, and the transmission distance can up to 50 meters (in open place).
- Wireless Charging**
 - The receiver and transmitter support wireless charging, and the standard wireless charging case meets multiple purposes of storage and charging.
- Long Battery Life**
 - After fully charged, the battery life of the device can up to 5 hours, and it can be extended to about 25 hours when used with the charging case, which can easily cope with long-time outdoor recording.

Product Specification



Mi3 Wireless Microphone System

- The charging case can charge the whole kit up to 4 times. It takes only 1.5h to recharge RX and TXs. After fully charged, TX and RX can be used up to 5 hours. If you use two TXs at a time, the whole system can work for 25 hours with the charging case. When taken out of the case, they are automatically turned on. When put inside, they are automatically paired and will start to charge if needed. Ready to use at anytime, anywhere.

Wireless Microphone System	
RF Carrier Frequency Range:	2400 MHz ~ 2483.5 MHz
Audio Frequency Response:	80Hz ~ 18KHz±3dB
Dynamic Range:	95dB (Circuit performance)
S/N Ratio:	95dB (Circuit performance)
SPL:	128dB SPL (Built-in MEMS mic)
Pairing Type:	Automatic
Effective Working Distance:	20m (there is block) 50m (in open space)
Working Temperature:	-5°C ~ +50°C

Battery Charging Case Specifications	
Charging box charging method:	Built-in lithium battery, standard USB 5V charging via Type-C interface
Battery capacity:	3000 mAh
Charging case usage time:	At full charge, charge the RX and 2 TX at the same time, providing up to about 4 charges.
Charging time:	TX: about 1.5 hours, RX: about 1.5 hours, Charging case: about 3.5 hours
Dimensions (mm):	130 (L) x 65 (W) x 53 (H)
Weight:	195 g

Mi3 Wireless Receiver



RF Carrier Frequency Range:	2400 MHz ~ 2483.5 MHz
Modulation Type:	Frequency hopping/Digital GFSK
Receiving Sensitivity:	-94dBm
Antenna Method:	Built-in F type antenna
Display Mode:	TFT display, showing battery power, current RF, AF status
Power Requirements:	Built-in lithium battery, standard USB 5V charging via Type-C interface
Battery Life:	About 4 hours
Output connector:	3.5mm TRS/interchangeable connector digital output
Output connector:	3.5mm onitor output
Working temperature:	-5°C ~ +50°C
Dimensions (mm):	71.5 (L) x 17.5 (W) x 25 (H)
Weight:	25 g
Headphone Monitor Output:	Yes

Mi3 Wireless Transmitter



- Latest generation ultra-low-noise digital microphone (inside the clip)

RF Carrier Frequency Range:	2400 MHz ~ 2483.5 MHz
Modulation Type:	Frequency hopping/Digital GFSK
Transmit Power:	10dBm
Antenna Method:	Built-in F type antenna
Microphone Pickup Method:	Omnidirectional (built-in MEMS mic)
Display Mode:	LED status indication
Power Requirements:	Built-in lithium battery, standard USB 5V charging via TYPE-C interface
Battery Life:	About 5 hours
Input Connector:	Type-C
Working Temperature:	-5°C ~ +50°C
Dimensions (mm):	21 (L) x 17 (W) x 54 (H)
Weight:	15 g

PM-100D

STEREO WIRELESS
IN-EAR MONITOR SYSTEM



PM-100D is a stereo wireless in-ear monitor system. The PM-100D receiver is made of plastic and weighs only about 55 grams (without battery). It is one of the lightest transmitter pockets on the market. The receiver adopts bright OLED display. At the same time, it has built-in 1-99 frequency group channels for selection, and can select the cleanest channel in a complex environment. Digital transmission technology can convert the input sound into a digital signal and send it to the receiver. During the digital communication transmission process, it can protect the integrity of the audio and prevent the accumulation of noise, so it is very suitable for: live streaming and small bands.

Key Features

UHF UHF Transmission Frequency Band

- Using the UHF frequency band, multiple systems can be used at the same time, the transmission is more stable and zero latency.

Easy to Carry

- The PM-100DR receiver's housing is made of a strong and lightweight material, weighing only 55 grams.

Widely Applicable

- Long transmission distance, suitable for various occasions.

Practical Functions

- 1U Half-Rack chassis made of metal
- Chassis Specifications
- The transmitter and receiver have a simple and bright multi-function display, which can make it easy for users to operate various settings.

Two output modes

- Stereo and mono output modes can be selected

Multiple audio outputs

- The receiver not only has a headphone output, it also has a line output, which you can connect to an active speaker to create a wireless audio transmission system.

PM WIRELESS IN-EAR
MONITOR SYSTEM

Product Specification



PM-100DR
Stereo Mini Receiver

Receiving Method:	Antenna reception
Carrier Frequency Range:	521.25MHz-936.85MHz
Modulation Method:	Integrated mode
Comprehensive T.H.D.:	<0.9%@1KHz
Stereo Separation:	≥65dB at 1KHz
Comprehensive Frequency Response:	20Hz-20KHz ±3dB
Batteries:	AA x 2
Current Consumption:	140mA (Typical)
Battery Life:	≤8 hours
Effective Working Distance:	80 meters (open place)
Output Socket:	Φ3.5mm stereo headphone socket
Output Power:	2×40mW at 1KHz (T.H.D: 0.03%)
Dimensions (mm):	198 (H) × 52.5 (W) × 25 (D)
Weight:	Approximately 55g (without battery)



PM-100DT
Stereo Transmitter

Chassis Specification:	1U Half-Rack
Carrier Frequency Range:	521.25MHz-936.85MHz
Modulation Method:	Integrated mode
Comprehensive T.H.D.:	<0.9%@1KHz
Frequency Bandwidth:	32MHz (depending on the region)
Comprehensive Frequency Response:	20Hz-20KHz ±3dB
Output Power:	60mW
Current Consumption:	160mA
Power Supply Mode:	DC 12V
Audio Output:	Φ6.3mm balanced socket × 2
Audio Input:	XLR and Φ6.3mm composite socket
Dimensions (mm):	205(W)×43(H)×206(D)
Weight:	Approximately 1kg

PM3 | CARDIOID DYNAMIC PODCASTING MICROPHONE BUILT-IN PREAMP



The PM3 is a professional dynamic podcasting microphone with XLR analog audio output. Built-in preamplifier, driven by +48V phantom power. Its wide frequency produces a warm, crystalline sound that makes it stand out! The microphone can be mounted to a wide variety of mic stands for flexible placement, making the PM3 the best choice for professional recording studios, podcasts, live broadcasts, and more. The PM3 can be connected to the Relacart Podcast+ digital podcast production console via XLR, giving the option to transmit the audio to mobile devices, computers and other devices.

PM CARDIOID DYNAMIC PODCASTING MICROPHONE

Product Specification



Microphone Type:	Dynamic
Polar Pattern:	Cardioid
Frequency Response:	80Hz-12KHz
Output Impedance:	30 Ω ± 30% (at 1 KHz)
Sensitivity:	-30dB ± 3dB (1V / Pa)
Power Requirements:	48V DC phantom power supply (IEC-61938) 4.5 mA(MAX)
Output Connector:	Built-in XLRM-3 pin XLR male
Dimensions (mm):	70 (Φ) × 180 (L)
Colour :	Black/White (optional)
Weight (g):	665

Polar Pattern

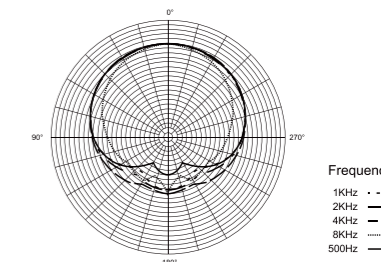

PM3
Cardioid Dynamic Podcasting Microphone

Frequency Response

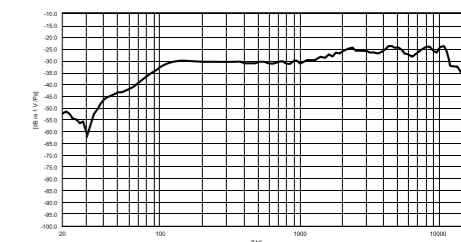

Key Features

48V Built-in preamplifier + 48V phantom power drive

- The PM3 dynamic podcast recording microphone offers an unparalleled audio recording experience. Its built-in preamplifier ensures high-quality recordings, eliminating concerns about signal loss or distortion. You can effortlessly capture clear and detailed sound, lending your recordings a more dynamic feel.

XLR XLR interface professional adjustment

- PM3 supports XLR output interface, which can be connected to the Relacart Podcast digital sound card mixer. The audio can be transmitted to mobile phones, computers and other devices through the mixer; whether it is daily or professional recording, you can use the mixer to adjust the audio to your satisfaction.

Soft vocals, full sound quality

- PM3 has a wide frequency response and full and soft sound quality. It is equipped with a windproof sponge and has excellent performance in close-range vocals. Ordinary people can also record charming sounds like professional anchors. It is an ideal choice for professional recording studios, podcasts. It is the microphone of choice in professional recording studios, podcasts, live broadcasts and other applications.

Wide response, quality microphone

- PM3 is equipped with a professional-grade high-quality microphone. The cardioid pattern is more suitable for human voice recording conditions and reduces the pickup of noise from the sides and behind. The 80Hz-14KHz ultra-wide frequency response makes the recorded sound moving. Not only is it the best choice for live streaming and video shooting, it can also be used as a sound collector in professional recording studios, bringing you wonderful sound.

Cardioid Pick-Up Pattern

- Cardioid polar pattern, provide excellent off-axis rejection, isolate unwanted ambient noise and eliminate echo, keeps your voice front and center when recording

Adjustable yoke for flexible placement

- PM3 comes with a versatile adjustable microphone yoke, which can be installed on various microphone stands to achieve flexible placement. It can be adjusted to the most suitable angle in any position, reducing the burden during recording, making it easy and convenient. to record a satisfying sound.

PM2

CARDIOID DYNAMIC
PODCASTING MICROPHONE



Pm2 dynamic podcasting microphone is a professional-grade microphone, which adopts the electromagnetic vibration induction technology to produce sound, makes the sound more real and natural, it's perfect for recording. The mission of PM2 is to bring musician's microphones out of the recording studio and better serve people's entertainment life! The PM2 noise-cancelling microphone has USB and XLR interfaces, and can be connected to computers, mobile phones and other terminals through USB data cables. At the same time, it is also a professional equipment for recording studios, which can be connected to a mixer through the XLR output interface to achieve a more precise tuning effects. PM2 adopts a double-antipop design, which can effectively reduce the noise of the environment and popping, and make your voice more pure and clear.



CARDIOID DYNAMIC
PODCASTING MICROPHONE

Product Specification



Microphone Type:	Dynamic
Polar Pattern:	Cardioid
Frequency Response:	80Hz-14KHz
Output Impedance:	600 Ω ± 30% (at 1 KHz)
Audio Sampling Rate:	24 bit / 48 KHz
Adjustable Gain Range:	0 ~+35 dB
Sensitivity:	-58 dB ± 3dB (1V / Pa)
Max. SPL Digital Output:	132 dB SPL
Headphone Output:	3.5 mm
Output Connector:	Built-in XLRM-3 pin XLR male and USB output
Mute Switch Attenuation:	Yes
Limiter:	Yes
Power Requirements:	Powered through Type-C USB connector
Dimensions (mm):	70 (Φ)×180 (L)
Weight (g):	695
Colour :	Black/White (optional)

PM2

Cardioid Dynamic
Podcasting Microphone

Key Features

Wide Compatibility

- PM2 can be connected via USB, including mobile phones (Android) and computers (Windows), as well as audio equipment such as mixers via XLR.

Dynamic Microphone

- Compared with the traditional condenser microphone, the PM2 dynamic microphone has a richer, fuller sound quality, and has obvious anti-noise ability, and it does not require DC operating voltage or power supply.

Standalone Application

- With Relacart MI.AUDIO application, when connect the PM2 to mobile phone or computer via USB, it can be automatically recognized by the application. With the built-in DSP processor, you can adjust microphone gain, microphone mute, equalization, monitor mixing, limiter and other functions. You can also connect PM2 to professional audio equipment via XLR.

Anti-interference

- PM2 cleverly uses PM2's metal bracket, and Relacart MI.AUDIO's application to achieve noise reduction and sound insulation on both the microphone itself and the program, so that your wonderful sound will not be interfered by the outside world to achieve triple protection!

Avariety of Sound Effects

- Users can set a variety of different sound effects on the Relacart Miaudio application, even a novice who does not understand tuning can easily use it, which makes PM2 broadcast a larger variety of wonderful sounds.

Convenient Operation
Reat-time Headphone Monitoring

- PM2 has a built-in touch panel, which is convenient for adjusting the microphone volume directly. You can adjust the microphone gain, earphone volume, monitor mixing, mute the microphone, lock the touch screen, etc.
- The microphone volume can be monitored in real time through the 3.5mm headphone jack to ensure perfect audio output.

MI.AUDIO software
main interface

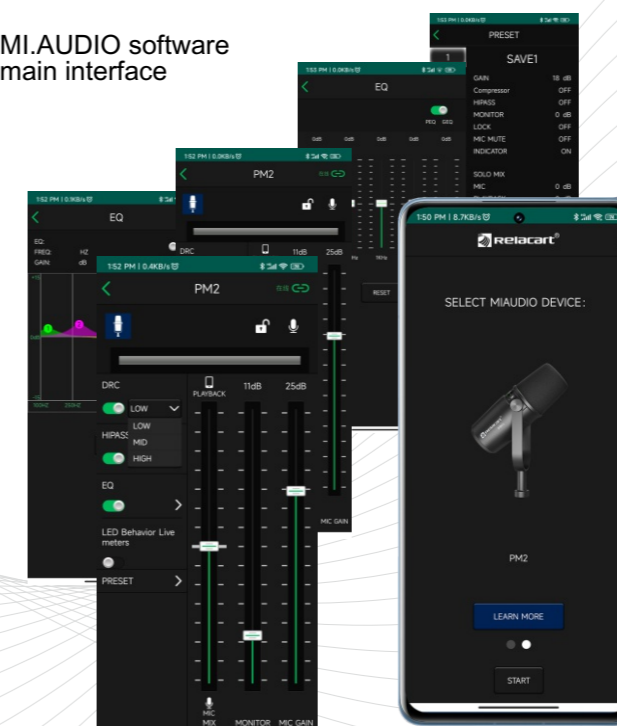

MI-AUDIO APP

Polar Pattern

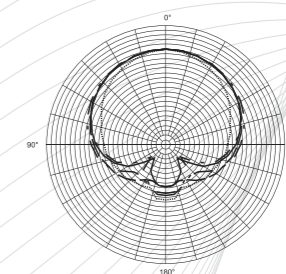

Frequency:
1KHz
2KHz
4KHz
8KHz
500Hz

Frequency Response

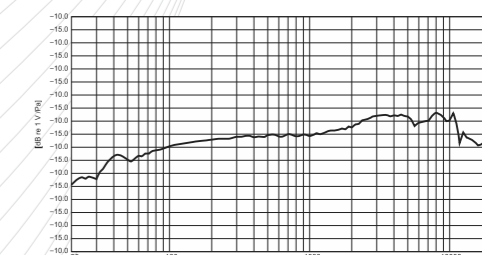

PM1 | CARDIOID DYNAMIC PODCASTING MICROPHONE



Relacart PM1 is a plug-and-play, easy-to-use broadcast-grade dynamic podcasting microphone that delivers rich, soft sound quality for excellent performance in podcasting, live streaming, and other voice or vocal applications. The PM1 features a rugged, all-metal construction with a sophisticated look and traditional XLR analog audio output, a wide frequency response, and a windscreen for close range vocal and instrumental recordings that are perfect for the fan-favorite convenience design. The widely-used microphone features an adjustable yoke that can be mounted on a variety of mic stands for flexible placement and will take your recordings to a whole new level.

PM CARDIOID DYNAMIC
PODCASTING MICROPHONE

Product Specification



Microphone Type:	Dynamic
Polar Pattern:	Cardioid
Frequency Response:	80Hz-14KHz
Output Impedance:	600 Ω ± 30% (at 1 KHz)
Sensitivity:	-58 dB ± 3dB (1V / Pa)
Output Connector:	Built-in XLRM-3 pin XLR male
Dimensions (mm):	70 (Φ) × 180 (L)
Colour:	Black/White (optional)
Weight (g):	665

Polar Pattern

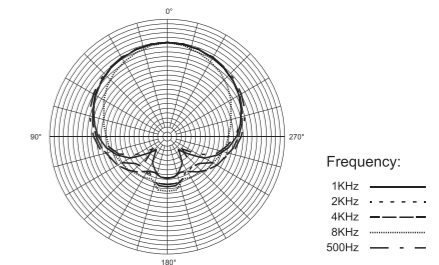

PM1
Cardioid Dynamic
Podcasting Microphone

Key Features

Anti-Interference

- Voice-Isolation technology delivers smooth and excellent detail sound while rejecting unwanted background noise and hum, for perfect recordings in imperfect rooms

Dynamic Microphone

- Compared with the traditional condenser microphone, the PM1 dynamic microphone has a richer, fuller sound quality, and has obvious anti-noise ability, and it does not require Phantom Power.

XLR XLR Output

- Features a high-quality XLR output easily integrates with your audio interface or external mixer. XLR cable is not included

Cardioid Pick-Up Pattern

- Cardioid polar pattern, provide excellent off-axis rejection, isolate unwanted ambient noise and eliminate echo, keeps your voice front and center when recording

Frequency Response

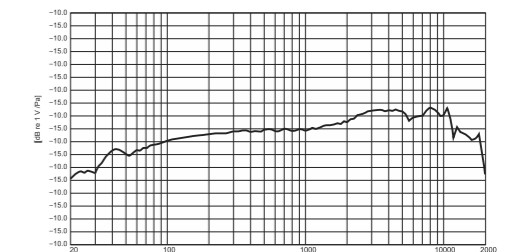

SM2 | SHOTGUN CONDENSER MICROPHONE



Sm2 is a shotgun condenser microphone specially designed for photography, interviews and recording. Adopts sound pickup interference principle and long sound collecting pipe design. It can provide high sensitivity and super-cardioid directional characteristics, resist radio frequency interference effectively and pickup more clear vocal sound. SM-2 built-in a 100Hz high-pass filter, which can prevent low-frequency noise effectively such as air conditioning and other environmental noises from being recorded. It can be powered by AA (1.5V) batteries or 48V phantom power for professional audio recorders, cameras and power supplies. Equipped with an anti-vibration frame, which can reduce the hard noise caused by the vibration of the equipment during photography and interview recording, and the attached windshield can minimize the slight wind and popping noise during the recording process.



Product Specification



Microphone Type:	Condenser microphone
Polar Pattern:	Super cardioid
Frequency Response:	50Hz-20KHz
Output Impedance:	350 Ω
SPL:	130 dB SPL, 1KHz@1%THD
S/N:	105dB (A weighted), 1KHz@1%THD
Dynamic Range:	>70dB
Sensitivity:	-45 dB@1V at 1Pa
Switch:	Through/High Pass Filter
Length(mm):	280
Weight (g):	110

SM2 Shotgun Condenser Microphone



Key Features

Super Cardioid

- Super-cardioid directional, providing high-quality recording effects.

High-pass Filter

- 100Hz high-pass filter selection.

Ultra-low Noise

- The circuit has low noise and clean recording.

Lightweight All-metal

- Metal structure, strong and durable.

XLR Output

- XRL 3-pin socket input and output.

48V 48V

- 48V phantom power or AA (1.5V) battery power supply.

Polar Pattern

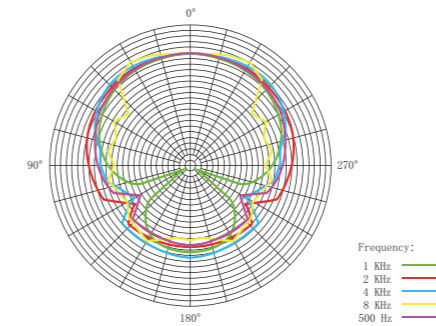

Frequency Response

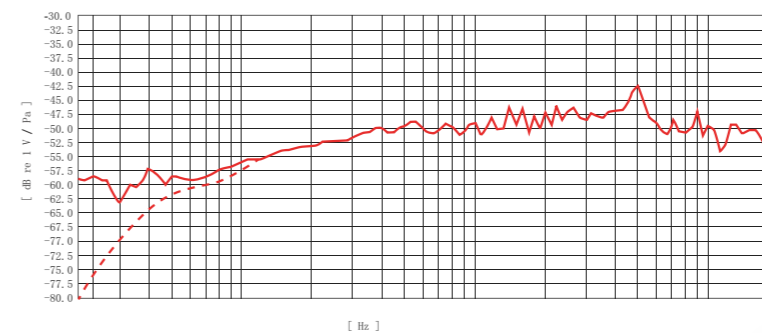

Product Specification



Sample Rates:	24-bit, 48 KHz
Frequency Response:	20Hz to 20 KHz
System Delay:	1.5ms
T.H.D.:	< 0.05%
Input Crosstalk:	> 65dB @ 1KHz (Adjacent Channels)
S/N Ratio:	90dB single channel - fader max (A-weighted)
Dynamic Range:	90dB single channel - fader max (A-weighted)
Common Mode Rejection Ratio:	> 60dB @ 1 KHz
MIC Impedance:	3kΩ (XLR Balance); 6.6kΩ (1/4)
MIC Gain:	0 to 45 dB (XLR)
Power Supply:	DC 5V (1A)
Dimensions(mm):	260 (L) × 230 (H) × 89 (D)
Weight:	1.5kg

Podcast+ is a podcast production studio specially designed for live streaming app, which collects the live application functions such as mixing, sound effects, and effects. Can connect 2 mobile phones or PC at the same time to transmit to live broadcast equipment through digital audio. Its design is light and easy to carry, the panel layout is simple, and the function distinction is clear and easy to understand. This device is powered by a USB-C interface 5V/1A and supports power from a suitable mobile phone charger or power bank. Podcast+ is suitable for live broadcast, recording, Karaoke and other functions of mobile phones, tablets and PC, etc.

Podcast+
Podcast Production Studio

Key Features

MIC.Prior/Duking

- When the MIC PRIOR switch is turned on, it automatically reduces the volume of background music and sound effects when there is audio input from the microphone

Intelligent Noise Reduction

- When the noise reduction switch is turned on, it reduces the ambient noise picked up by the microphone.

Simulate On-site Reverberation

- Podcast+ has 16 simulated live reverb effects internally, which can be selected according to the live content to enhance the atmosphere of the live broadcast.

Custom Sound Effects

- Comes with 9 built-in sound effects, which can be replaced via USB.

2 Headphone Outputs

2 Digital Audio Inputs/Outputs

High-pass Filter

3 High-Quality Inputs

48V Phantom Power Supply

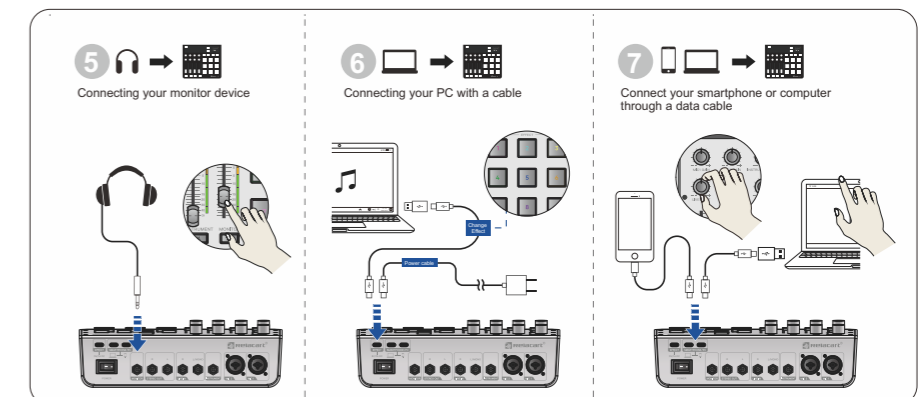
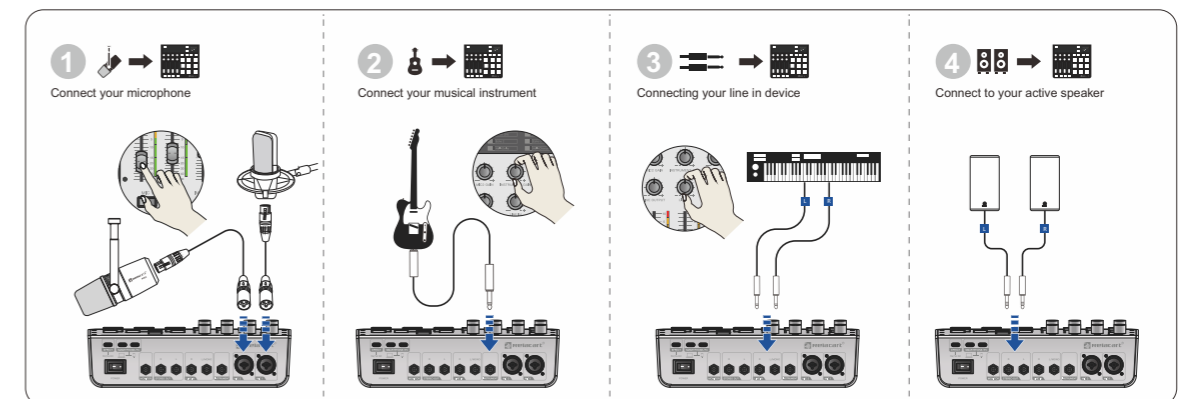

MIXX8.6

LIVE STREAMING LOOPBACK
AUDIO USB MIXER

MIXX8.6 8-CHANNEL
DIGITAL MIXER



Compatible with
Relacart
Mi.Audio app

MIXX8.6 digital mixer designed with 8 inputs and 6 outputs. Built-in digital audio processing functions, such as effect, EQ, compressor, etc. And it is equipped with a USB interface, which can transmit audio by mobile phones and computers. It has 16 types of digital reverb effects, which can be easily adjusted for various occasions with the encoder. It has a simple and exquisite appearance, with reasonable layout of function buttons, suitable for various small-scale performances, conferences, speeches, KTV, live streaming, and other occasions.

Product Specification



Sample Rate:	24bit, 48kHz
Frequency Respond:	20 Hz to 20 kHz +0/-1 dB
T.H.D. :	<0.1%
Signal to Noise Ratio:	90 dB Single channel max fader (A weighted)
Dynamic Range:	100dB Single channel max fader (A weighted)
Common Mode Rejection Ratio :	>70 dB @1 kHz
MIC Input Impedance:	3.3k Ω (XLR Balance); 1.8 kΩ (1/4")
LINE Input Impedance:	10K Ω (1/4")
Output Impedance:	150 Ω
Gain:	0 to 60 dB (XLR)
FOOT SW :	REVERB ON/OFF
Phantom Power Supply:	+48V
USB Audio:	2IN/2OUT compliant with USB audio class 2.0
Power Supply:	DC 5V (1A)
Power Consumption:	Up to 5W
Dimensions(mm):	260(L)×230(H)×89(D)

Key Features

Multifunction Panel

- The mixer panel can turn on and off various functions, including EQ, mute, compressor, reverb, 48V phantom power, etc.

Eight Channel Input

- 1-4 input channels can select MIC or LINE input source. 3 and 4 input channels can be set as instrument input sources. Channel 5-8 is stereo input, can switch H/L impedance.

48V Four input channel, with 48V phantom power supply

- 1-4 channels can provide +48V phantom power supply, which is controlled by panel button switches.

Multiple Audio Modes

- USB output can be set in multiple audio modes to suitable for various applications.

Professional Reverb Effect

- Professional reverb function, which can simulate various sound effects.

Real-time Monitor

- MIX MINUS will exclude the audio of input channels 1-4 from local playback and monitoring.

MIXX8.6

8-Channel Digital Mixer

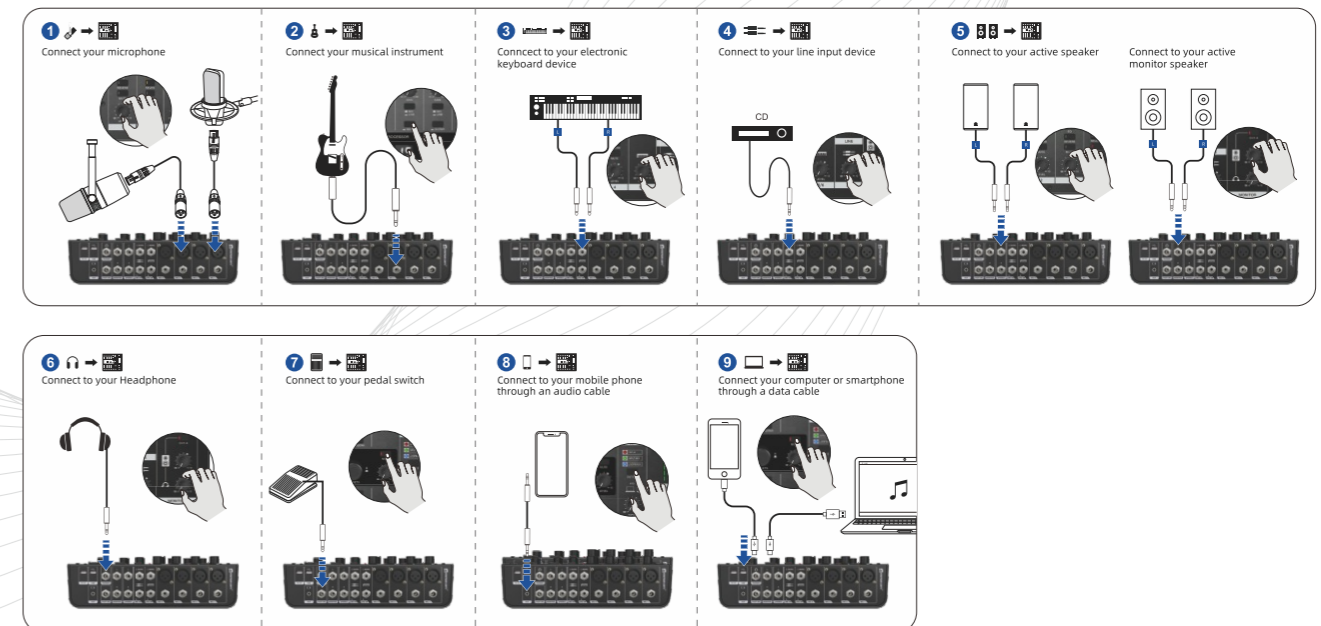



Relacart Mikit series is a portable stereo digital audio converter. It can be connected to a mobile device through the USB-C interface. Use with MI.AUDIO application software. Built-in DSP processor, you can set the input gain, monitor volume, high-pass filter, limiter, equalizer, mono/stereo switch, preset and other functions. It is widely used in recording, video recording, online communication, etc. Compatible with iOS (Only for Mikit-i version), Android, Windows, Mac (Only for Mikit-i version), plug and play.

Product Specification



Model:	Mikit-c (USB-C) Mikit-a (USB-C) (not yet available) Mikit-i (USB-C) (not yet available)
Gain Adjustment Range:	0 ~ +35dB
Frequency Response:	20Hz ~ 20KHz
Sampling Rate:	48K
Equalizer:	5-band graphic equalization / 5-band parametric equalization, switching applications
High Pass Filter:	75Hz / 150Hz
Limiter:	High / Medium / Low three-level adjustment
Case:	All metal structure, light and small, easy to carry
Dimensions(mm):	Mikit-c: 47(H)×47(W)×13(D) Mikit-a: 210(H)×47(W)×13(D) Mikit-i: 210(H)×47(W)×13(D)
Weight:	Mikit-c: 30g Mikit-a: 40g Mikit-i: 40g

Mikit.c/Mikit.a/Mikit.i
Mobile Interview Kit

Key Features

- 3.5mm Dual Microphone Input
- Mono/Stereo Mode Switch
- 3.5mm Monitor Outputs
- Lightweight
- APP application
• Pairs with relacart MI.AUDIO App.
- Widely Compatible
- Smart Chip
- Customizable Sound Quality
- Dual 3.5mm TRS Connection



MI.AUDIO APP

LM-P01 | LAVALIER MICROPHONE



Relacart LM-P01 is a very light and convenient omnidirectional lavalier microphone with a pure copper gold-plated straight head and a fixing ring. It can provide broadcast-quality recording with close-range pickup, suitable for application in noisy environments. It can be directly connected to various wireless systems or SLR cameras and other equipment.

Product Specification

S/N:	>65dB
Frequency Response:	50Hz-20KHz
Impedance:	2.2KΩ
Capsule Dimension(mm):	Ø7.5×18
Sensitivity:	-39dB±2dB (0dB=1Pa)
Polar Pattern:	Omnidirectional
Microphone Connector:	Gold-plated straight head, 3.5mm TRS interface with nut
Diameter Of Cable(mm):	Ø2
Length:	1.2m / 6m



LM-P01
Lavalier Microphone

Key Features

Powerful Functions

- has the characteristics of pure, clear audio and noise-reducing. The user-friendly omnidirectional pickup mode and the smallest appearance make it an important tool for vlog, podcast, interview, drama, speech and any other that requires high-quality recording but not revealing the microphone. The omnidirectional pickup pattern and lavalier effectively reduce background noise and improve the recording quality of mobile devices. The included high-density spray-proof foam windshield ensures that high-quality recordings can be obtained in harsh environments.
- 1.2m and 6m length options, can be used in various scenes.

Clear Sound Quality

Omnidirectional

Ultra-low Noise

Polar Pattern

Frequency:

- 1000Hz
- 2000Hz
- - - 4000Hz
- · - · - 8000Hz
- · · · · 500Hz

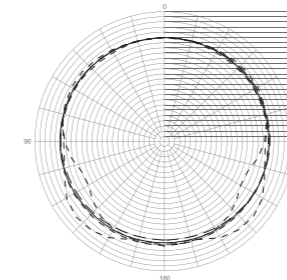

Frequency Response

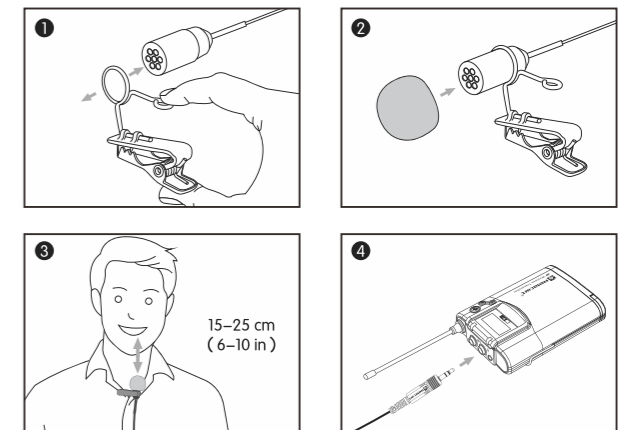
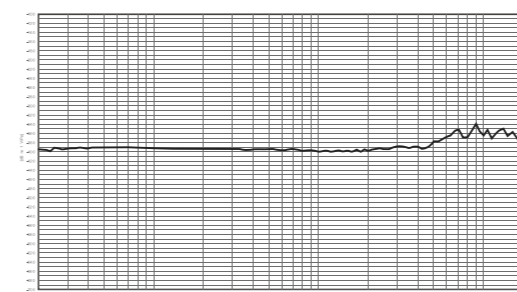

1. To fit your LM-P01 onto clothing and connect to your wireless system or recording device, mount the LM-P01 into the provided lavalier clip. Hold the clip between two fingers, with one finger pressing down on the end of the wire loop. This will create enough leeway to insert your LM-P01 through the wire.
2. Install the supplied snug-fit windscreen by sliding it over the microphone capsule. (Note: Do not pull the windscreen too tightly over the microphone. Leave a small space inside the windscreen to allow for air movement.)
3. Attach the microphone to a shirt or other garment using the supplied tie clip. For best results, the microphone should be 15-25 cm (6-10 in.) away from the mouth.
4. Plug the 3.5 mm (1/8") plug into your wireless system or recording device.

ACCESSORIES

Product Specification



- Relacart MiH is a handheld adapter that can convert Mi series transmitters into small handheld interview microphones. With high-density furry windshields to minimize wind noise and provide in all recording scenarios effectively.

Handheld Adapter Dimensions (mm):	<ul style="list-style-type: none"> • Diameter: 21.5 • Width: 40 • Height: 210 • Weight (g): 500
Compatible Relacart Mi series Microphones	
Windshield Dimensions (mm):	<ul style="list-style-type: none"> • Diameter: 64.5 • Height: 71.5 • Weight (g): 6

MiH Handheld Mic Adapter



Mi Microphone Windshield

- Mi windshield is a design of artificial fur, specially used in outdoor and strong wind conditions, reducing wind and blasting noise effectively.

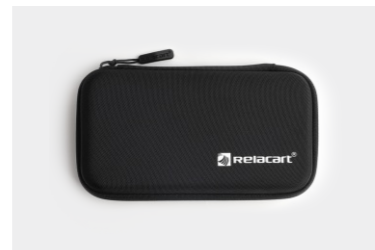

Mi Storage Bag

- It is suitable for Mi series products, with comprehensive protection and excellent portability.

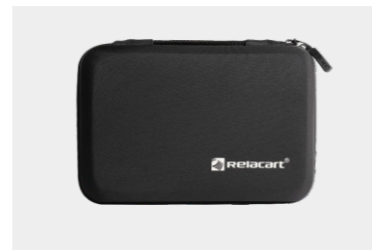

CR Storage Bag

- It is suitable for CR series products, with comprehensive protection and excellent portability.

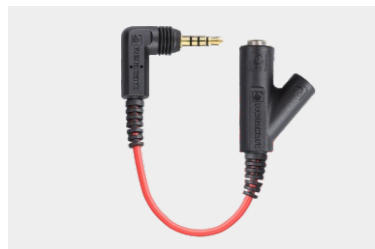

ME4-J
(TRRS to 3.5mm jack)

- ME4-J is a TRRS to 3.5mm splitter headphone output and microphone input conversion cable, which is specially designed by Relacart for mobile phone karaoke applications, and supports mobile phone and tablet karaoke.
- Support for Android and other system mobile phones and new generation computers 2 in 1 four-level input socket



EC-A03-CJ
(TYPE-C to 3.5mm jack)

- ME4-C is a TYPE-C to 3.5mm splitter connector headphone output and microphone input conversion cable, which is specially designed by Relacart for mobile phone karaoke applications, and supports mobile phone and tablet karaoke.
- Support for Android and other system mobile phones and new generation computers 2 in 1 four-level input socket



ME4-L
(Lightning to 3.5 jack)

- ME4-L is a Lightning/Lightning to 3.5mm splitter connector headphone output and microphone input conversion cable. It is specially designed by Relacart for mobile phone karaoke applications. Supports mobile phone and tablet karaoke. Effectively solve the phenomenon that the condenser microphones on the market cannot be incompatible with the IPHONE/IPAD
- Support IOS system, Android system does not support temporarily, has nothing to do with the conversion line.

ACCESSORIES

Product Specification



Unbalanced audio cable

- XLR (female) to 6.35mm double-core shielded cable, mainly used for mono transmission.



Unbalanced audio cable

- Generally, the pins in the microphone, the mono and dual channels in the audio, use this 6.35mm audio pin to achieve the sound quality transmission effect. So that our sound quality can be played more smoothly, and it sounds more comfortable.



Balanced audio cable

- Suitable for connecting between professional microphones and professional equipment, such as mixing consoles, sound cards, power amplifiers, equalizers, compressors, crossovers, digital decoders, professional microphones connected to cameras, and other equipment. Broadcast-grade professional XLR male-to-female Balanced microphone cable, XLR microphone cable, special fine copper wire twisted, durability is particularly good. It is suitable for stage sound, press conference, KTV, professional sound reinforcement, home theater and other environments. sounds more comfortable.



TRS to XLR (female)

- Connect one end of the XLR three pin XLR female to the output jack at the end of the microphone, and connect one end of the 3.5mm plug to the device (SLR) 3.5mm jack.



3.5mm balanced connecting wire

- This is a 3.5mm TRS (black) to TRS (black) cable with thread lock, which is used to connect wireless microphone to digital SLR camera or mobile device.



Shoe-mount adapter

- Applicable to CR1 CR2 series Bodypack receiver



Microphone Sponge Windshield

- The sponge windshield provides additional protection from wind noise or popping sound to the microphone. sounds more comfortable.

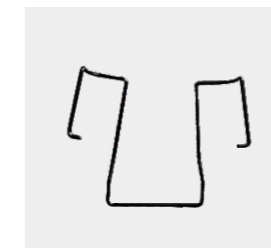

Bodypack Transmitter Belt Clip

- Fix the transmitter or receiver around the waist of the user.

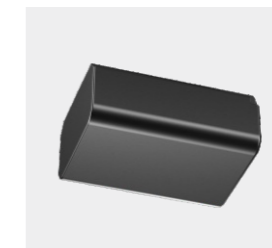

RB-FW50 Lithium battery

- Battery Weight: 46g ±2g



Rechargeable battery

- High capacity, low internal resistance, low self-discharge, one hour rapid charging and long cycle life.

PROJECT APPLICATION

Stage and Music Performances

HR-31S | HR-31S provides audio support for Wendeng Nanhai Fudi Water World



PROJECT APPLICATION

Stage and Music Performances

UR-2Q+WAM-432 | UR-2Q wireless microphone system helped a college to celebrate the 100th anniversary of the founding of the



PROJECT APPLICATION

Stage and Music Performances

HR-31S+R-32AU | 7th CISM Military World Games



PROJECT APPLICATION

Stage and Music Performances

The Fourth Guangdong Sports Industry Development Forum in 2020

The famous host Wu Jiahua, Yang Jin teacher used the "Relacart wireless microphone" to open, to deliver the most clear and loud voice



PROJECT APPLICATION

Stage and Music Performances

The 2020 FINA CHAMPIONS SWIM SERIES

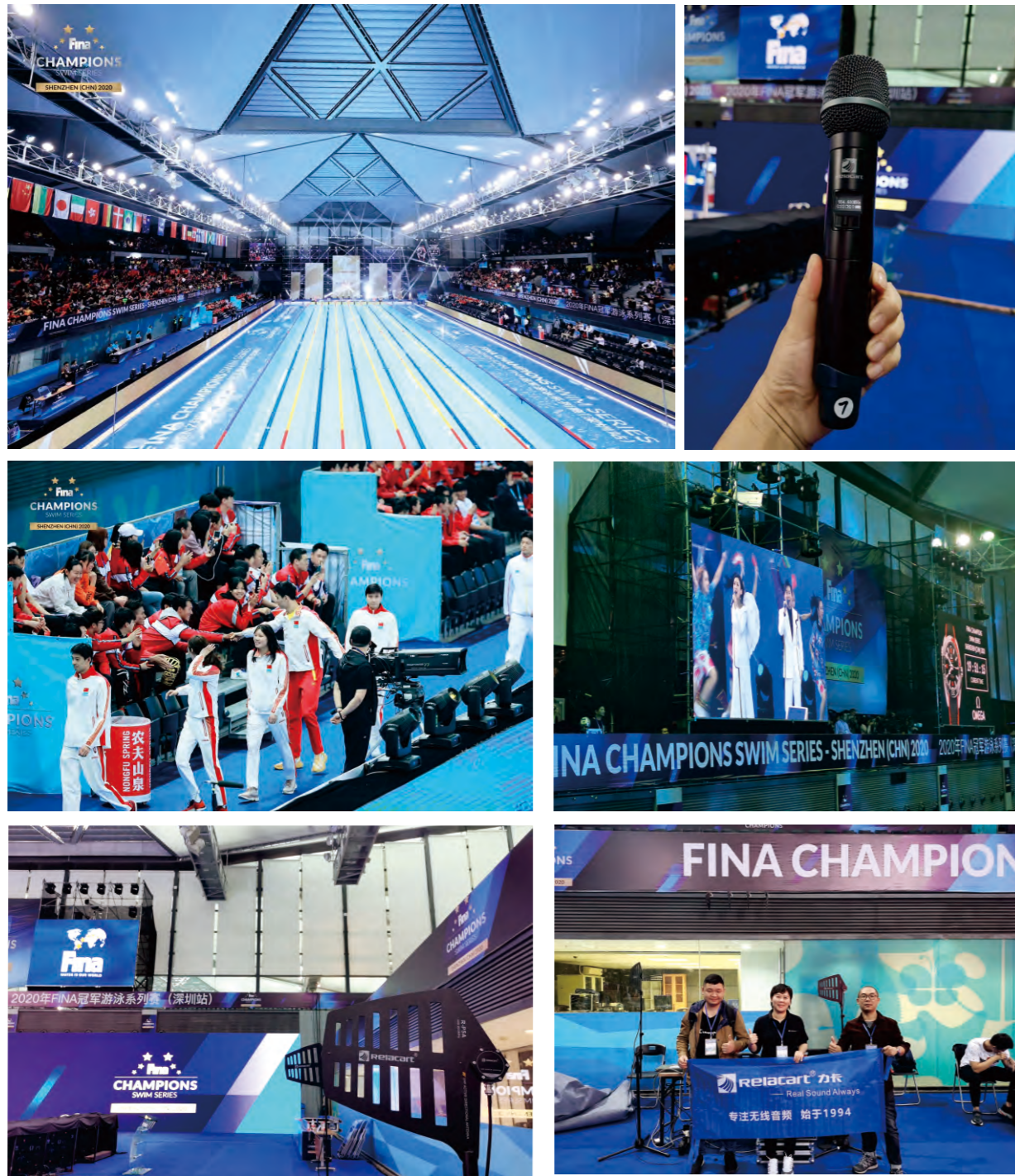

PROJECT APPLICATION

Stage and Music Performances

The 2020 FINA CHAMPIONS SWIM SERIES



PROJECT APPLICATION

Stage and Music Performances

HR-31S+UR-223S | 2019 Guangzhou Asian Food Festival Exhibition

Opening & Closing Ceremony



韓國歌手專場



PROJECT APPLICATION

Stage and Music Performances

HR-31S+UR-223S | 2019 Guangzhou Asian Food Festival Exhibition

On-site equipment

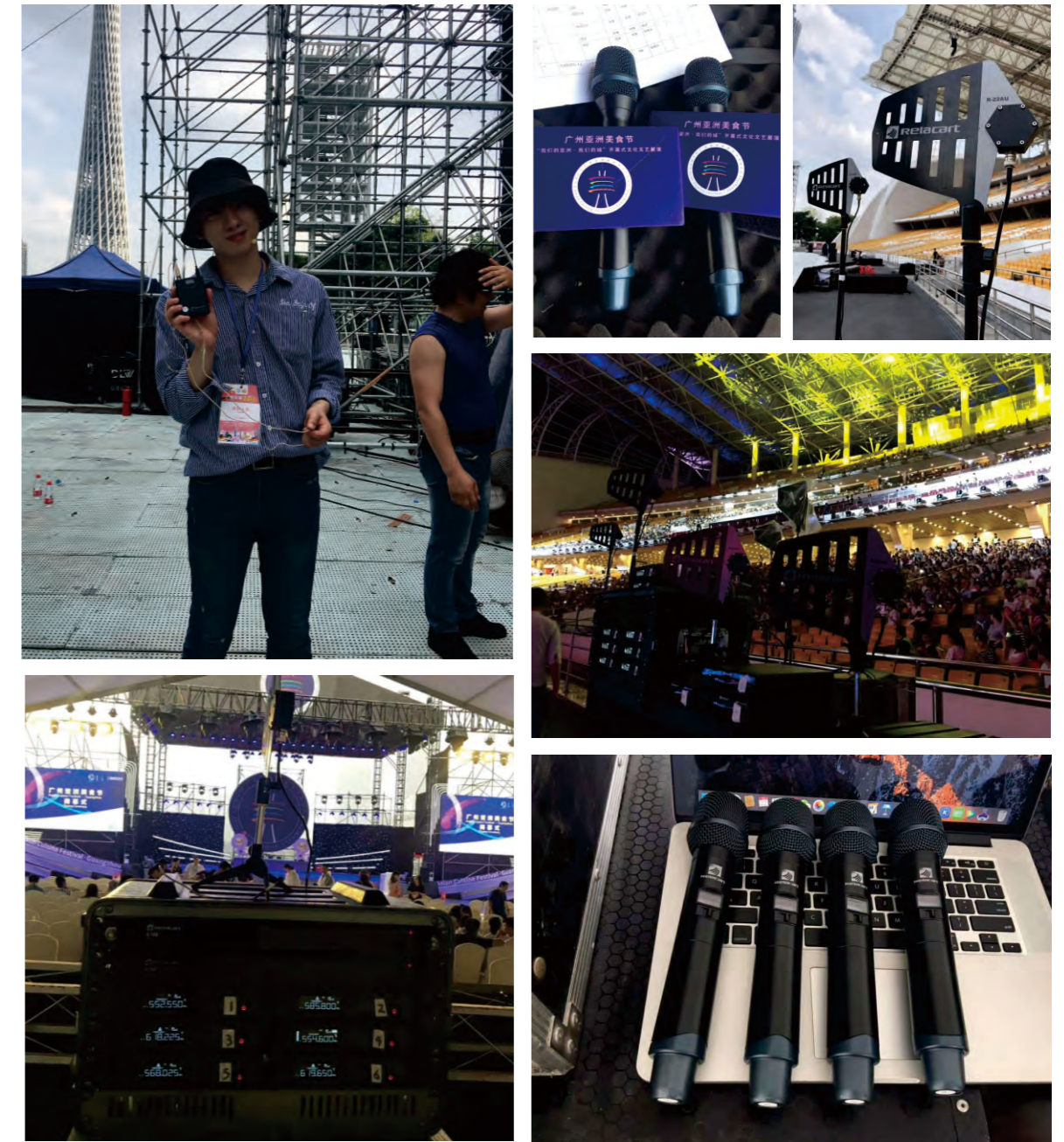

PROJECT APPLICATION

Stage and Music Performances

HR-31S | Sun Yang double crown! Relacart professional performance audio system to help the 2019 FINA swimming champion! Relacart Microphone boarded CCTV news!

Cool stylistic performance show, singer uses Relacart H-31 wireless performance microphone



▲ The H-31 wireless handheld microphone is full of low-frequency, and the sound quality is penetrating and passionate, leading the audience to a warm and cheerful atmosphere.



PROJECT APPLICATION

Stage and Music Performances

HR-31S | Sun Yang double crown! Relacart professional performance audio system to help the 2019 FINA swimming champion! Relacart Microphone boarded CCTV news!

At the exciting event scene, the compere used Relacart P1 wireless microphone broadcast the record in real time, and interview the swim champion athlete.

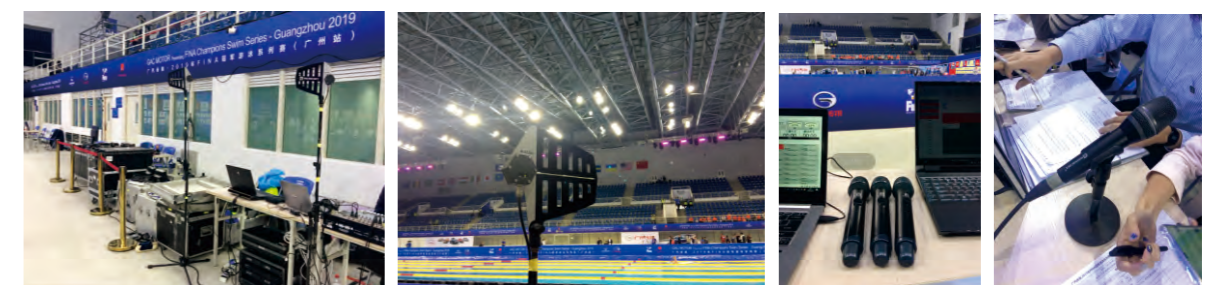

▲ The use of R-22AU directional antennas to compensate for the problem of wireless transmission signal attenuation caused by large number of people on the large stage and strong wireless interference.

▲ The compere uses Relacart PM-100 professional wired condenser microphone

PROJECT APPLICATION

Stage and Music Performances

HR-31S | 2016~2018 GuangZhou International Light Festival



PROJECT APPLICATION

Stage and Music Performances

HR-31S | 2016-2018 stars shine in Guangdong New Year's Carnival

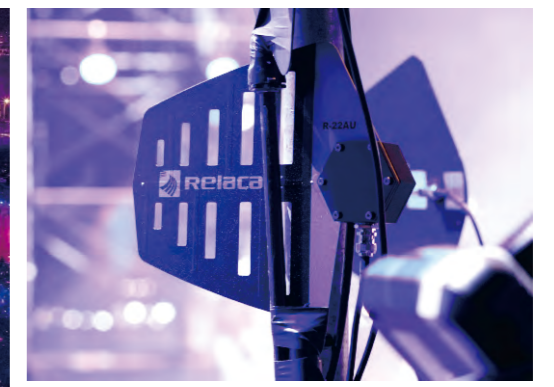

PROJECT APPLICATION

Stage and Music Performances

HR-31S | 2016 Sun Nan "Happy in" World Tour Concert Foshan Station

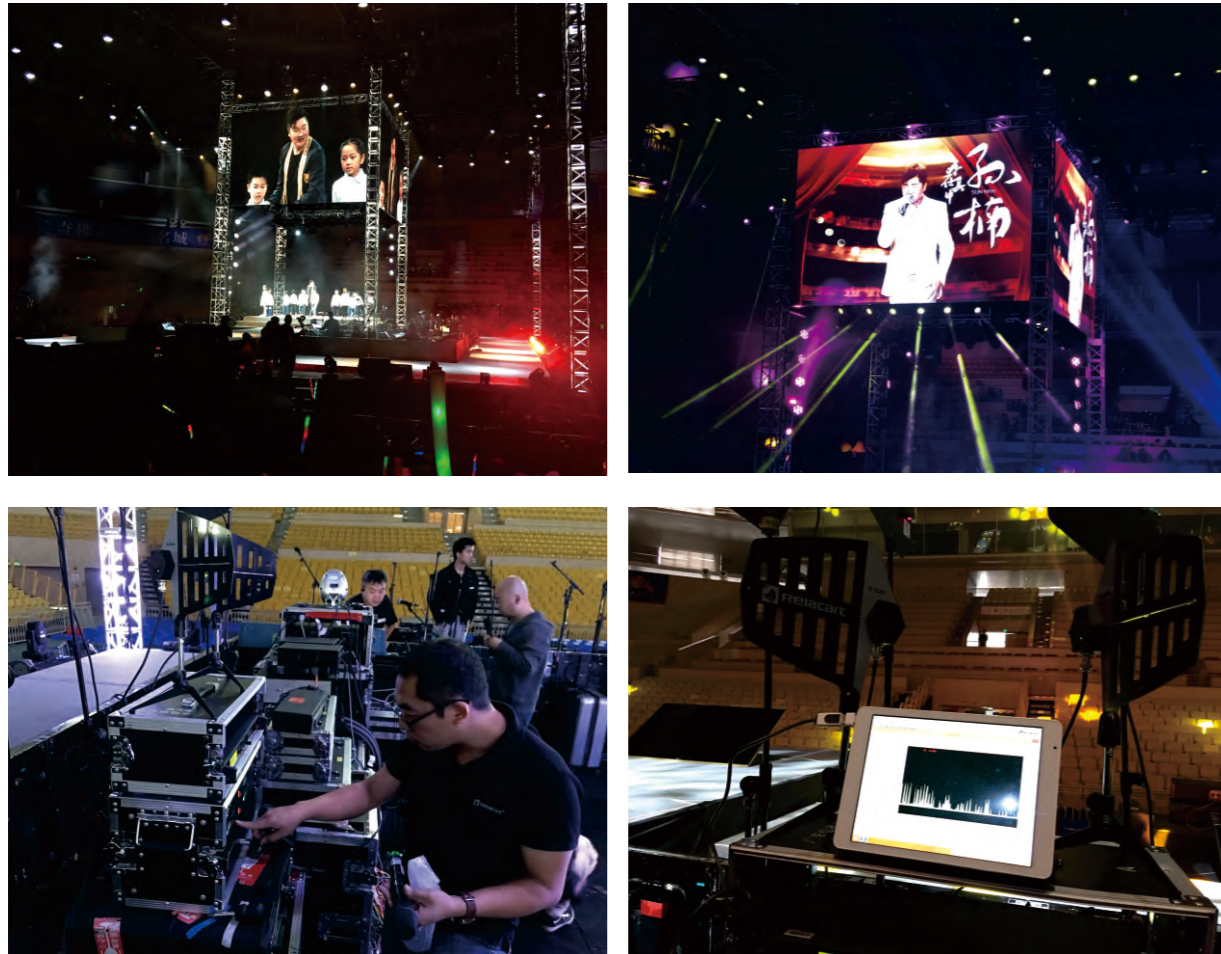

PROJECT APPLICATION

Stage and Music Performances

HR-31S | 2016-2018 BONBON LAND Music Festival



PROJECT APPLICATION

Stage and Music Performances

HR-31S | 2017 China Cup International Football Championship



PROJECT APPLICATION

Stage and Music Performances

HR-31S | GuiZhou ten kilometers outdoor project



PROJECT APPLICATION

Stage and Music Performances

HR-31S | GRAND HOTEL



PROJECT APPLICATION

Stage and Music Performances

HR-31S | GRAND HOTEL



PROJECT APPLICATION

Stage and Music Performances

HR-31S | The Captain

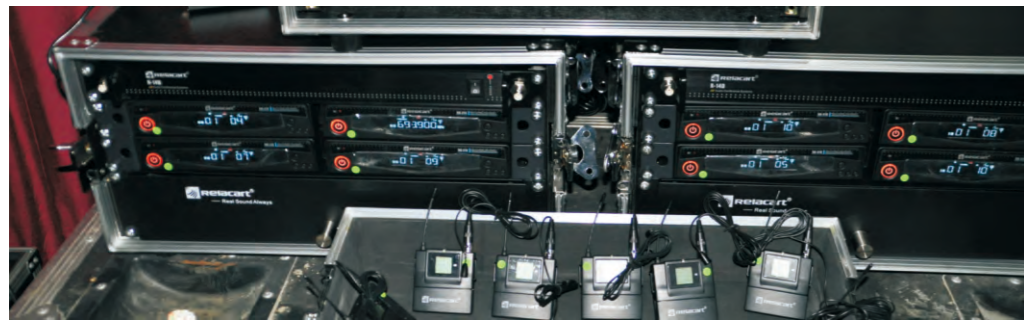

PROJECT APPLICATION

Stage and Music Performances

HR-31S | The third Valley



PROJECT APPLICATION

Stage and Music Performances

HR-31S | GREASE



PROJECT APPLICATION

Stage and Music Performances

HR-31S | "Sweeney Todd" performed in Shanghai Theatre Academy



PROJECT APPLICATION

Stage and Music Performances

HR-31S | "Playme" performed in Ji Nan



PROJECT APPLICATION

Stage and Music Performances

HR-31S | "Playme" performed in Guangzhou



PROJECT APPLICATION

Stage and Music Performances

HR-31S | CONTACT



PROJECT APPLICATION

Stage and Music Performances

HR-31S | "Qiqin" concert in Nanning City

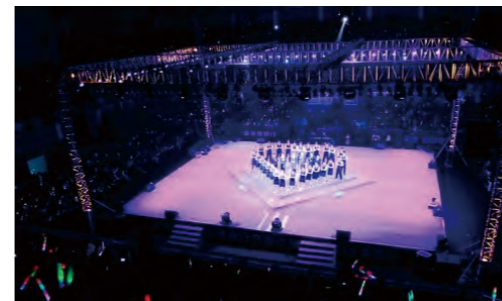

PROJECT APPLICATION

Stage and Music Performances

HR-31S+UR-223D | Chen Wen Nu teacher and student, friends, spring festival



PROJECT APPLICATION

Stage and Music Performances

HR-31S | Relacart Performance Series-Danfeng County 2024 Spring Festival Gala



PROJECT APPLICATION

Stage and Music Performances

R-31S / UR-2Q / R-32AU / UR-223S / UR-260D | Relacart settled in the Senior High School Affiliated to Changzhou Academy of Educational Sciences, with a modern overall audio system

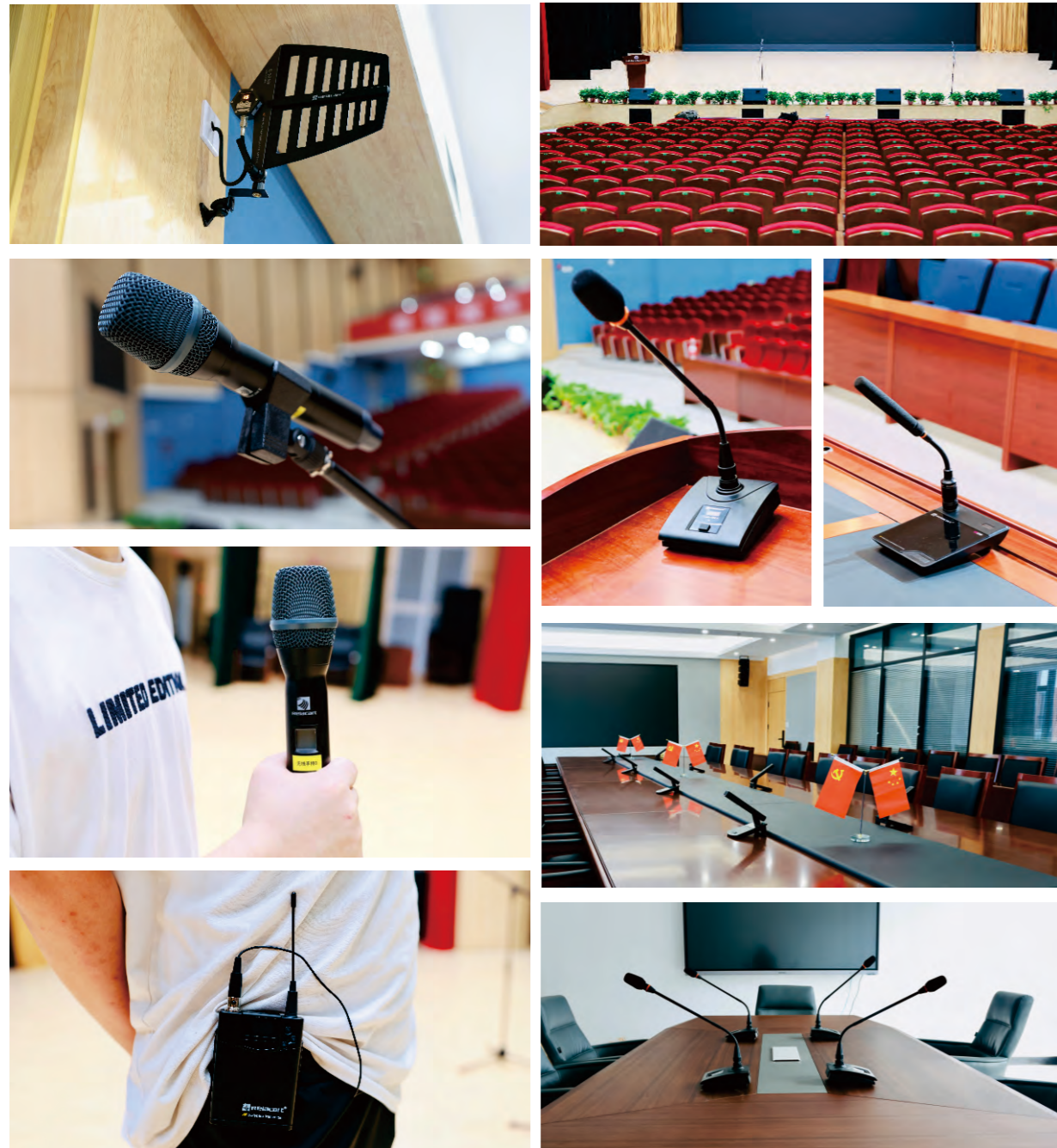

PROJECT APPLICATION

Stage and Music Performances

UR-2Q | Relacart joins hands with BYD to strive for the glory of domestic technology!



PROJECT APPLICATION

Stage and Music Performances

UR-2Q | Relacart provides audio support for Latin American union prayer event



PROJECT APPLICATION

Stage and Music Performances

UR-2Q R-32AU | Leader's Choice | Relacart Wireless Microphone Escorts the Peruvian President's Speech!



PROJECT APPLICATION

Stage and Music Performances

UR-223D | Dual channel true diversity wireless microphone system with the Greater Bay Area Racing Carnival to enjoy the wild



PROJECT APPLICATION

Stage and Music Performances

UR-223D | Dual-channel true diversity wireless microphone system helps a Jin Opera troupe in Shaanxi Province



PROJECT APPLICATION

Stage and Music Performances

UR-223S | Sun Yang double crown! Relacart professional performance audio system to help the 2019 FINA swimming champion! Relacart Microphone boarded CCTV news!

After the event, the news media used the Relacart P1 single channel true diversity professional wireless performance microphone



PROJECT APPLICATION

Stage and Music Performances

UR-223S | 2019 Jiang Xiaobai YOLO Youth Culture Festival Guangzhou Changlong Station

Live event



PROJECT APPLICATION

Conferencing Projects

UR-222D+R-20U | XCMG Group



PROJECT APPLICATION

Conferencing Projects

UR-222D | IAAF GLOBAL RUNNING CONFERENCE CHINA 2019



PROJECT APPLICATION

Stage and Music Performances

UR-223S | 2019 Jiang Xiaobai YOLO Youth Culture Festival
Guangzhou Changlong Station

The compere and singer uses Relacart to perform microphone



▲ Locking & Wacking mixed 2V2 event, the compere used Relacart P1 wireless performance microphone



PROJECT APPLICATION

Stage and Music Performances

UR-223S | 2019 Jiang Xiaobai YOLO Youth Culture Festival
Guangzhou Changlong Station

Build the scene- Relacart technical team photo

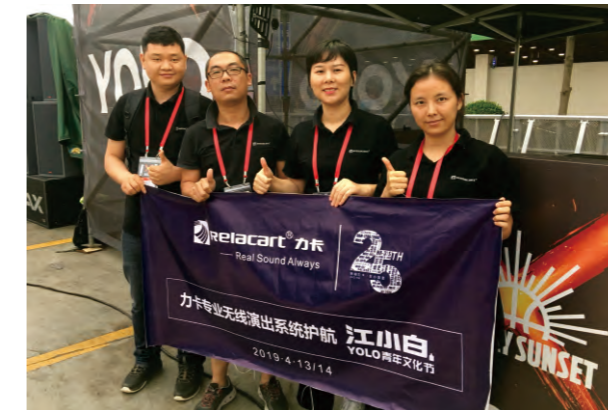

PROJECT APPLICATION

Stage and Music Performances

UR-222D | UR-222D dual-channel diversity wireless microphone system helps in the Healthy China Marathon



PROJECT APPLICATION

Stage and Music Performances

UR-222S | Relacart Electronics joins hands with Rizhao Municipal government to welcome the 25th Games of Shandong Province and respond to the national call of "national fitness"

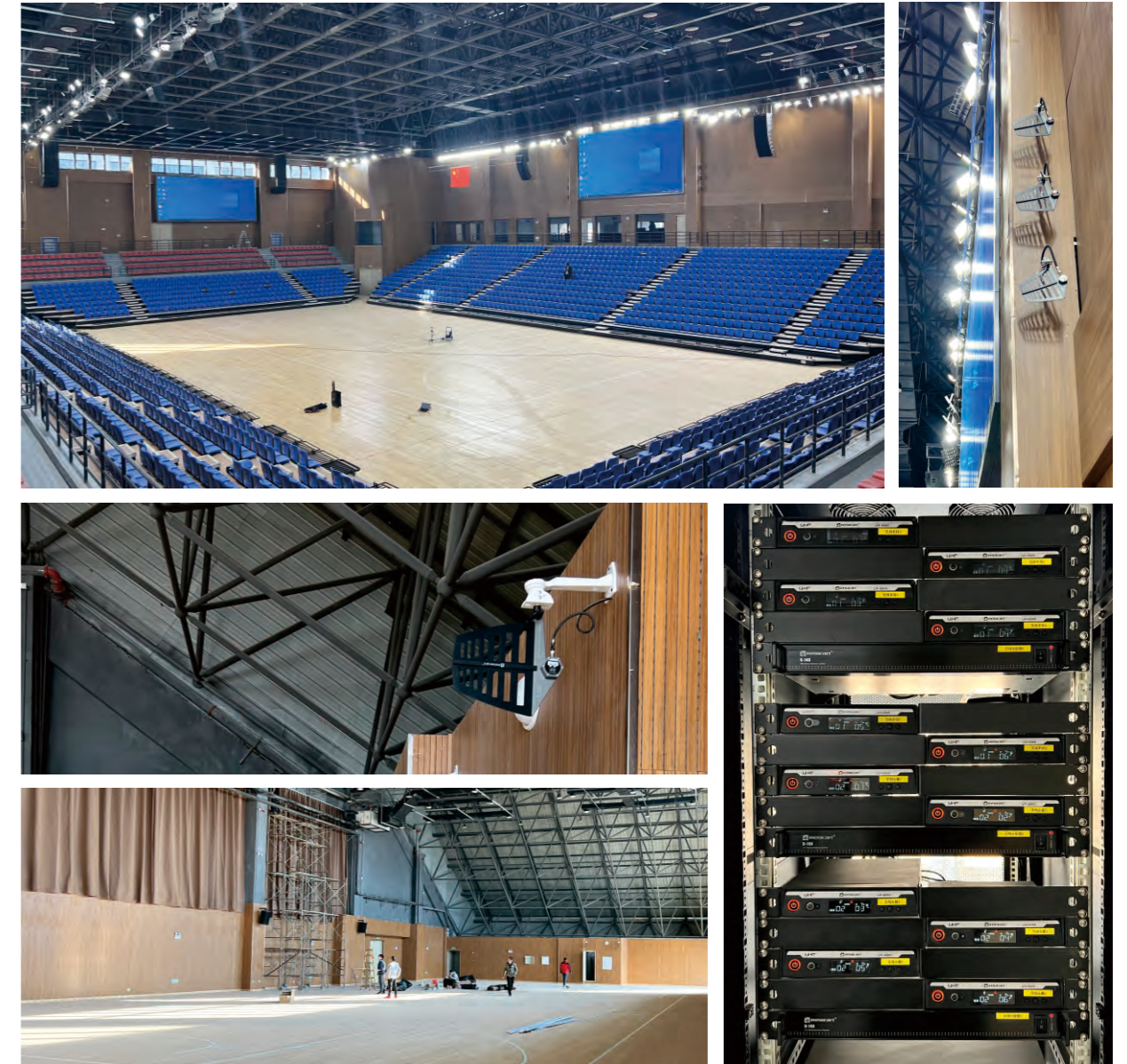

PROJECT APPLICATION

Stage and Music Performances

UR-111D | Building the future of education together | Relacart wireless microphone system settled in Fuqing Chengguan Primary School!



PROJECT APPLICATION

Stage and Music Performances

UR-222S | Relacart Electronics joins hands with Rizhao Municipal government to welcome the 25th Games of Shandong Province and respond to the national call of "national fitness"

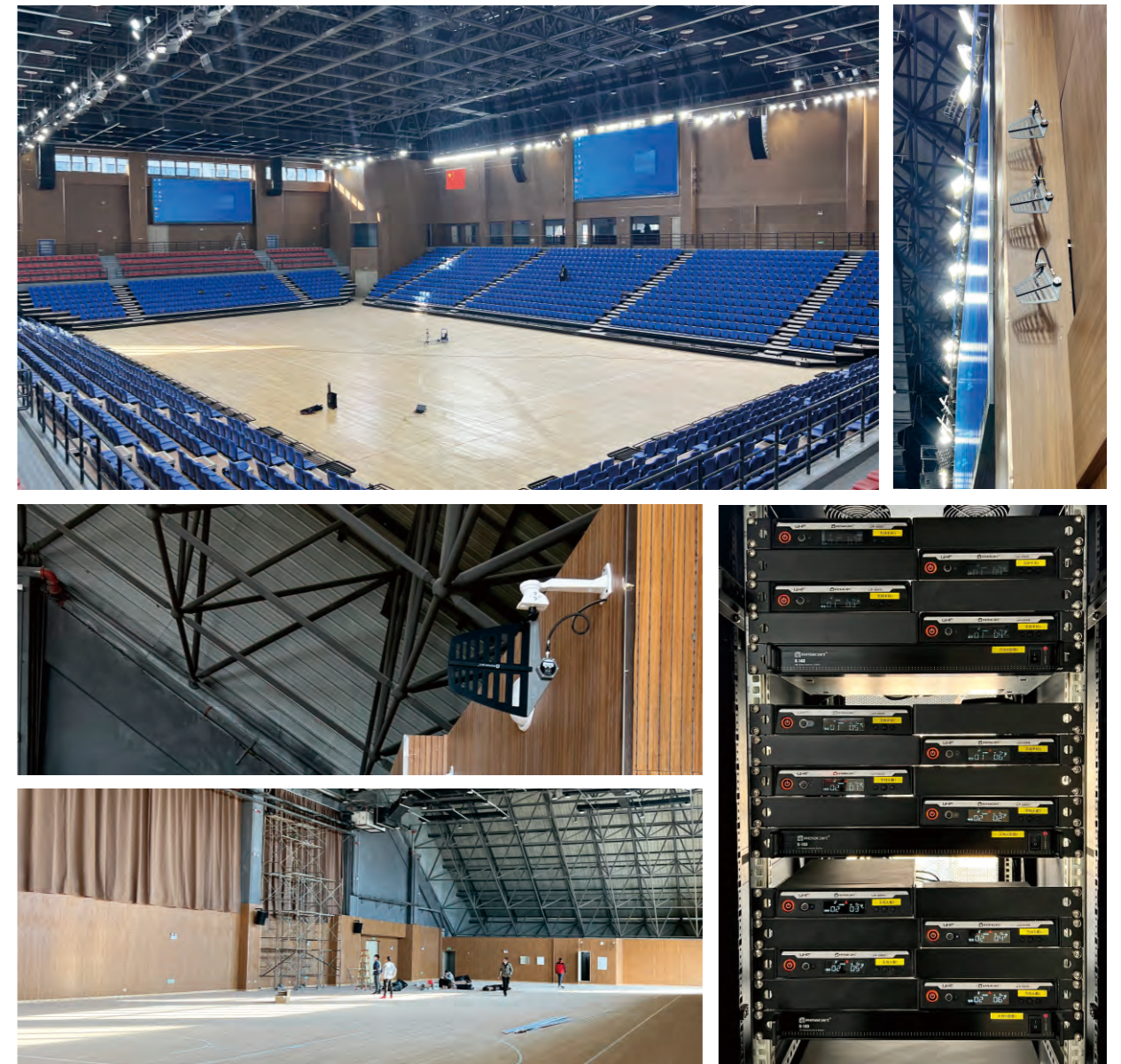

PROJECT APPLICATION

Stage and Music Performances

UR-222S | Relacart UR-222S single channel wireless microphone system appeared in the Brilliant Life Hall of Malaysia



UR-223D | UR-223D contributes to the 13th Gesar Racing Festival



PROJECT APPLICATION

Stage and Music Performances

UR-5700+UD-1+R-32AU | Baokang County Secondary Vocational and Technical School "Youthful style, Forge ahead on a new journey" May 4th Youth Day art performance



PROJECT APPLICATION

Conferencing Projects

UR-5700+WDC-900

WDC-900 digital wireless conference system is installed in the multi-functional lecture hall and conference room



PROJECT APPLICATION

Conferencing Projects

WDC-923

Weifang Shengyi Audio Engineering Co., Ltd. shows "Meet the future company exhibition hall" with WDC-923

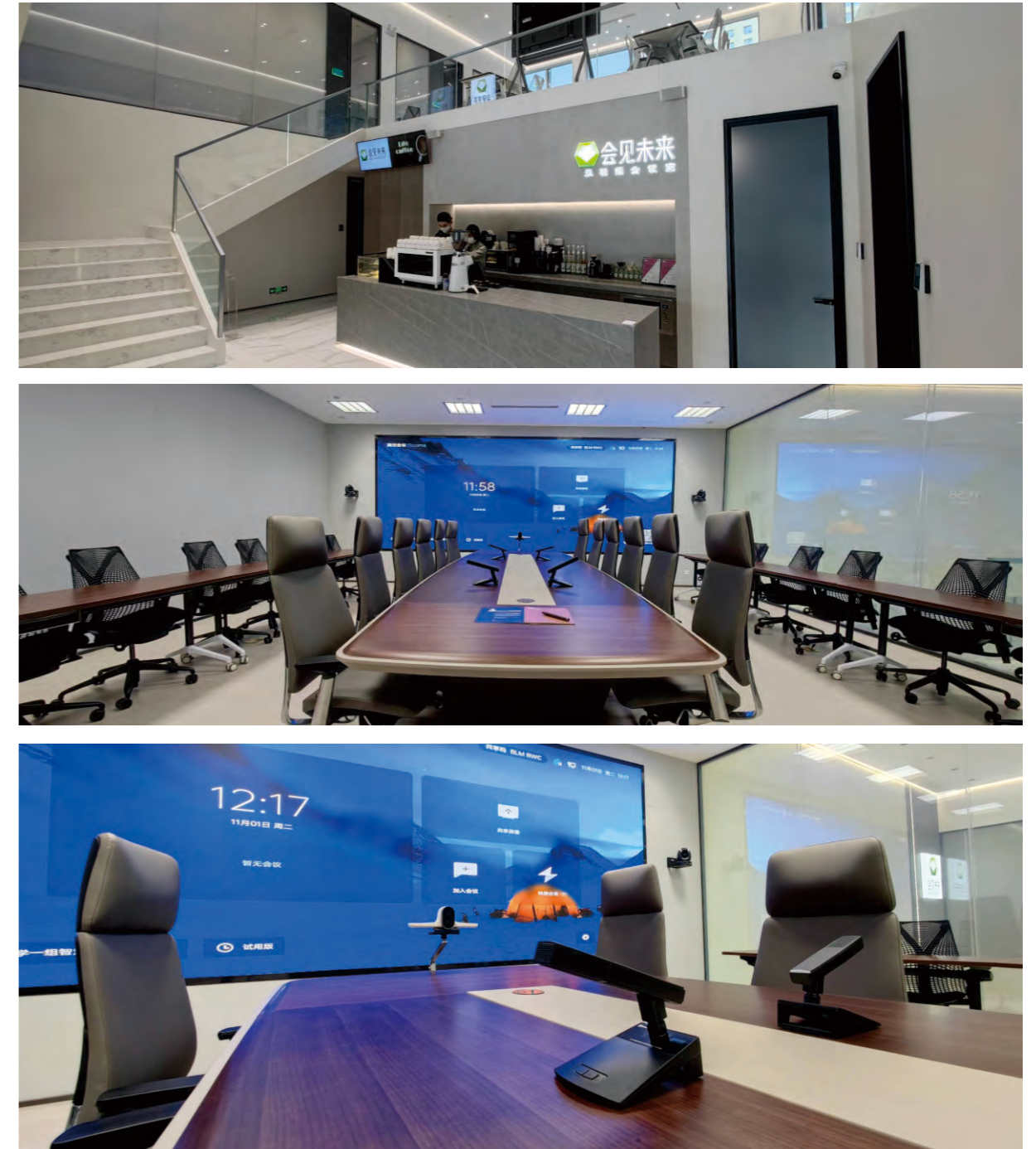

PROJECT APPLICATION

Conferencing Projects

WDC-923+MAS-D | Multi-functional conference hall of a group company in Yunnan



PROJECT APPLICATION

Conferencing Projects

WDC-903 | Multi-functional conference hall of a Fortune 500 energy group



PROJECT APPLICATION

Conferencing Projects

WDC-903 | The WDC-903 digital wireless microphone system is used in the conference room of a Buddhist university in Myanmar



WDC-903 | WDC-903 digital wireless conference and discussion system is installed in a multi--functional conference hall of a municipal government department



PROJECT APPLICATION

Conferencing Projects

WAM-432+UR-260D | WAM-432 automatic intelligent wireless mixing system was installed in Shandong Province for staff training



PROJECT APPLICATION

Conferencing Projects

WAM-432+ AMC-20 | JADEWARE DISTINCTIVE TOWN OF WANTOU
YANGZHOU Co., Ltd.



WAM-432+ UB-222 | Relacart WAM-432 Wireless Automatic Mixer system settled in a conference room of a bank in Chile!



PROJECT APPLICATION

Conferencing Projects

WAM-402 | Shandong 271 Education Group



PROJECT APPLICATION

Conferencing Projects

WAM-402 | Changchun chinensis coal industry limited company



WAM-402 | Suzhou Industrial Park



PROJECT APPLICATION

Conferencing Projects

WAM-402 | Anhui Fuxin Media



WAM-402 | CDC of Tianyuan District, Zhuzhou City



PROJECT APPLICATION

Conferencing Projects

**WAM-402+UH-222
UD-222**

Guandu District Teachers Training School, Kunming City,
Yunnan Province



PROJECT APPLICATION

Conferencing Projects

WAM-402+CS-100 | Hunan Yongzhou Bureau of Land and Resources



WAM-402 | The people's Government of Zhengzhou



PROJECT APPLICATION

Conferencing Projects

CS-302+CS-501+EU-610 | CS-302 wired professional digital conference and discussion system is stationed in the conference room of the Standing Committee of Tianyuan District



PROJECT APPLICATION

Conferencing Projects

CS-302+TSG-910+UR-260D | Guandu District Teachers Training School, Kunming city, Yunnan province

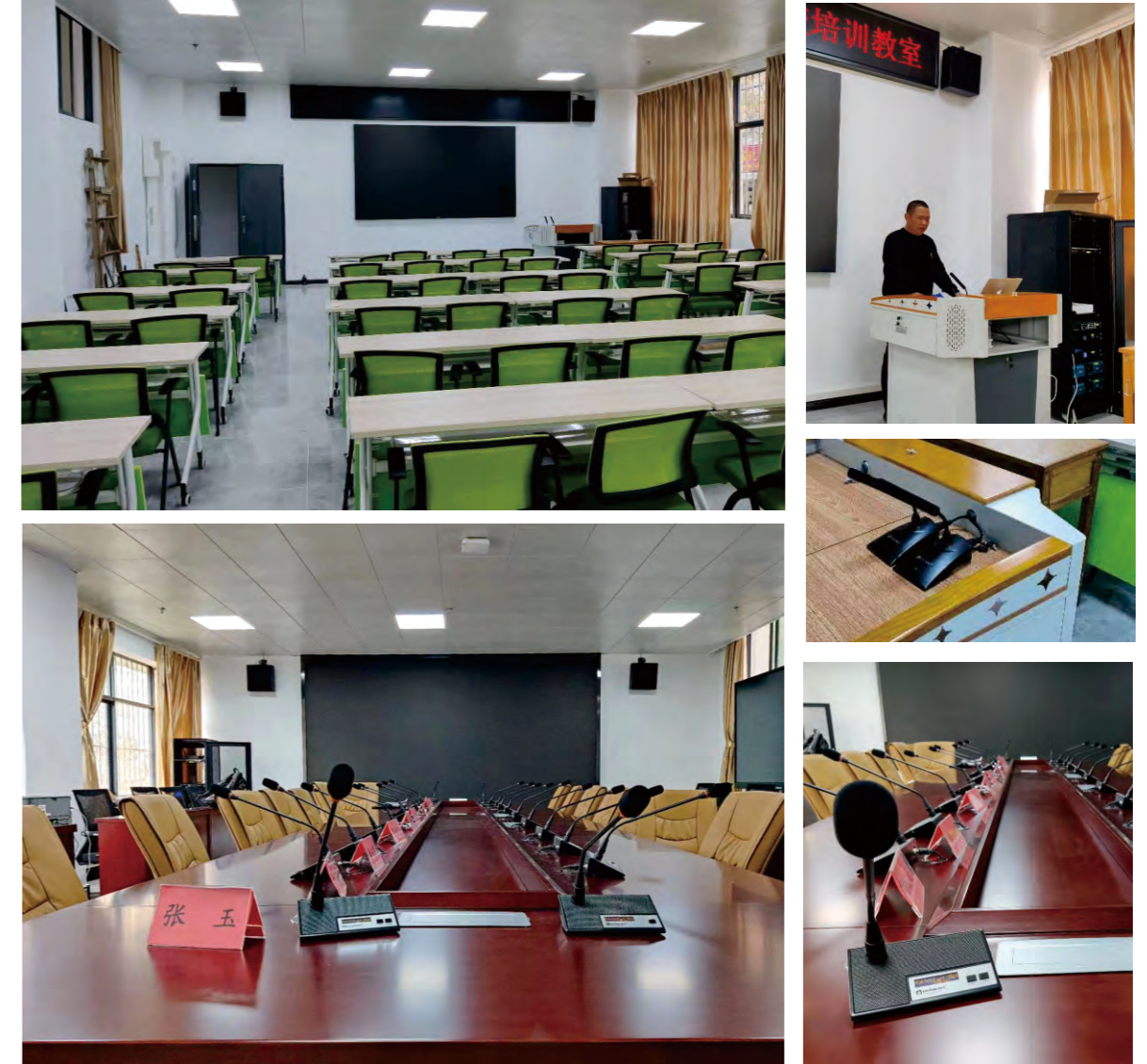

PROJECT APPLICATION

Conferencing Projects

CS-302M +CS-501C+CS-501D | Conference Room 402, Kunming Branch of China Minsheng Bank



PROJECT APPLICATION

Conferencing Projects

CS-302+GF-923 | Tongren City, Guizhou Province government upgrade conference room



PROJECT APPLICATION

Conferencing Projects

CS-302 | Relacart provides an efficient meeting experience for a cost-effectiveness firm in Hunan Province!



CS-302 | Zhejiang Junsheng Holdings Co., Ltd.



WB-100 | An aviation university in Malaysia



PROJECT APPLICATION

Conferencing Projects

CS-101 | Korea Jeonju National Pension Corporation



CS-101 | Kunshan Municipal People's Congress Standing Committee



PROJECT APPLICATION

Conferencing Projects

CS-100 | THE 2nd CHINA-ISRAEL MEDICAL TECHNOLOGY INDUSTRY SUMMIT FORUM



PROJECT APPLICATION

Conferencing Projects

CS-100 | Asian Youth Press Conference



CS-100 | The people's Procuratorate of Yulin City



CS-100 | China Mobile



CS-100 | Ordos Convention and Exhibition Center



CS-100 | ZhongXin Bank Conference Room



CS-100 | YinchuanZhongwei people's conference room



PROJECT APPLICATION

Conferencing Projects

DAM-128D+TSG-600 | Nanchang Greenland Group



PROJECT APPLICATION

Conferencing Projects

TDN1 | Committee of Changchun city Jilin Province

TDN1 Microphone Desk Stand with Dante Network Output



Match Relacart Dante conference microphone management control software RDM1.0



The TDN1 + ES-910 is a Dante desktop microphone for quick installation of a gooseneck microphone output from XLR. The stand is designed for placement on a flat surface and provides high quality radio, conference and distance learning applications Match Relacart Dante conference microphone management control software RDM1.0 can directly set the microphone input gain, low cut, working mode, phantom power supply. The software has audio level visualization, distortion indication.

Dante™ Global professional network audio transmission technology

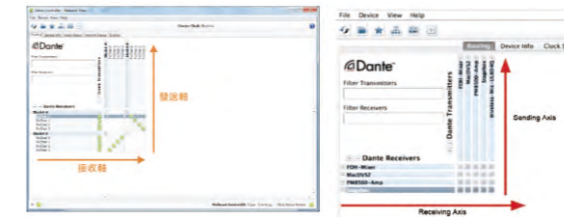

Dante Global professional network audio transmission technology
The TDN1's audio output can be routed using Audinate's Dante controller and the software can be downloaded from the Audinate website (www.audinate.com).
The site also provides Dante's routing control and software instructions.

Network audio solution

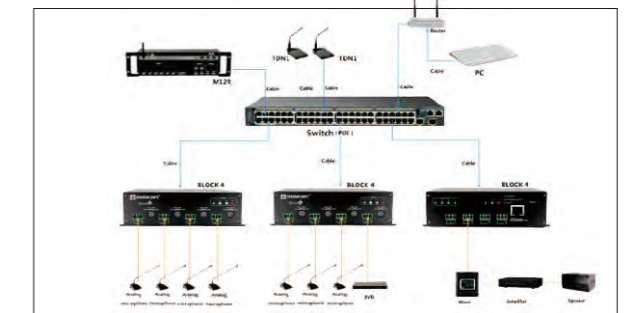

TDN1 digital network audio conferencing architecture



PROJECT APPLICATION

Conferencing Projects

CONFER X + TDN-1 + BLOCK4

Room 503, 5th Floor, Committee of the CPPCC of Zhuzhou City



PROJECT APPLICATION

Conferencing Projects

**UR-2Q + CONFER X
UD-223 + TSG-550**

Conference Room, Zhuzhou Culture and Tourism Radio, Television and Sports Bureau of Gailiyang Town People's Government, Shunyi District, Beijing



PROJECT APPLICATION

Conferencing Projects

CONFER X +TDN1&ES-910 | Huairou Campus of Beihang University strives to build a modern software and hardware development laboratory



PROJECT APPLICATION

Conferencing Projects

UR-222DMB+UR-111DMH +CS-302+CS-501 | Replace and upgrade the conference system of digital rural command Center in Huarong District



PROJECT APPLICATION

Conferencing Projects

MAS-D | Relacart MAS-D Dante Microphone Array settled in the conference room of a company in Wuhan



PROJECT APPLICATION

Conferencing Projects

TM-500 +R-32AU | The Botanical Garden uses the TM-500 wireless microphone system to amplify the sound of the garden

Wireless Relacart, Craftmanship Spirit

TM-500 Dual Channel True Diversity Wireless System
Application Project Connection Diagram

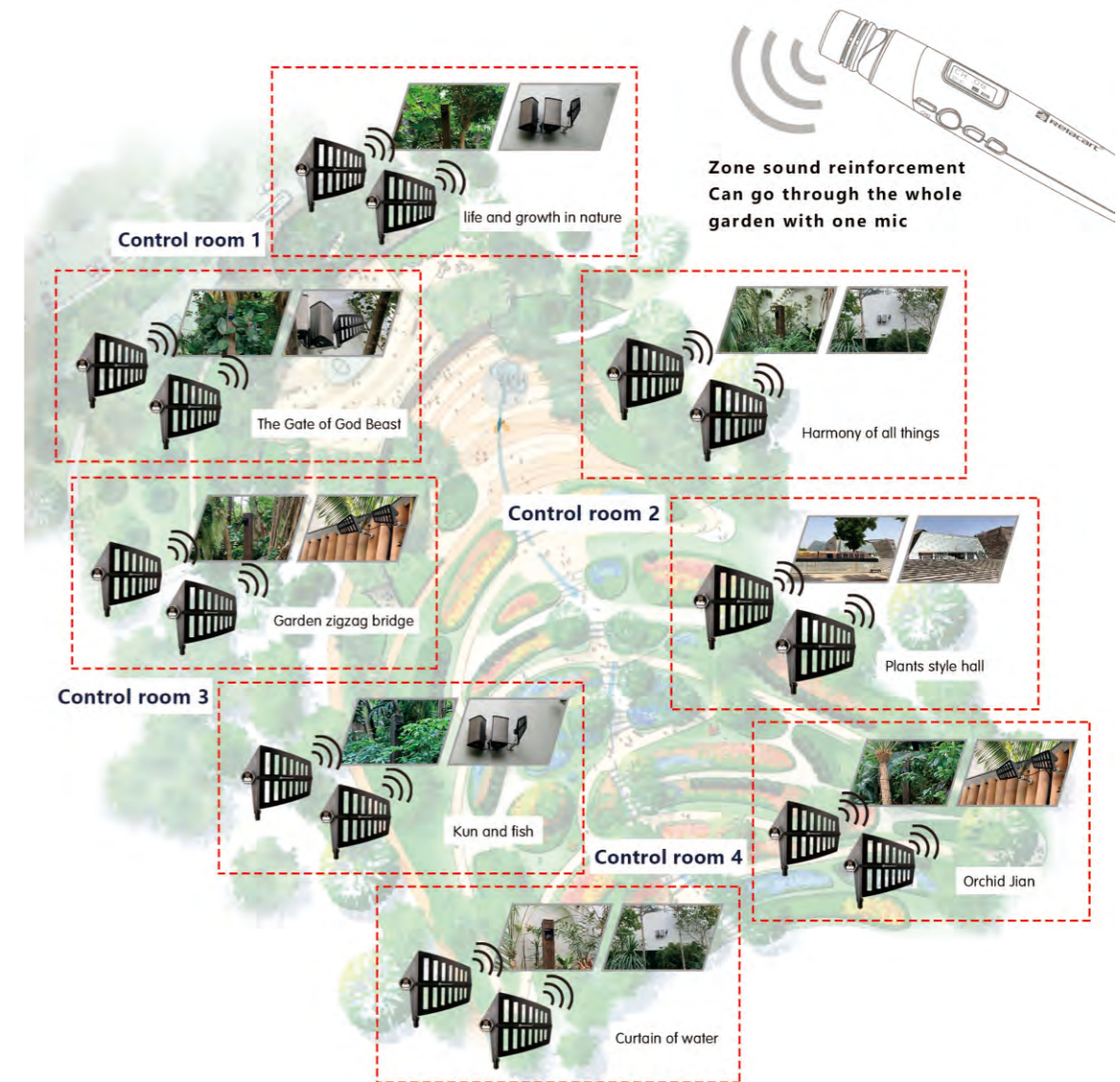

PROJECT APPLICATION

Conferencing Projects

WDC-900 | Wuhan Changjiang Daily Media Group



PROJECT APPLICATION

Conferencing Projects

WDC-900 | Hunan National Tax



PROJECT APPLICATION

Conferencing Projects

WDC-900 | Guangle Highspeed



WDC-900 | Lanhai International Hotel of Linyi City



PROJECT APPLICATION

Conferencing Projects

WDC-900 | GuangZhou Zhenguang High School



WDC-900 | Nanping Branch of Industrial & Commercial Bank



PROJECT APPLICATION

Conferencing Projects

WDC-900 | Hager Communication



WDC-900 | Hunan Yongzhou Bureau of Land and Resources



PROJECT APPLICATION

Conferencing Projects

WDC-900 | Power Supplier of Shouguang City, Shandong Weifang



WDC-900 | Huaian District Government Conference Room



PROJECT APPLICATION

Entertainment and KTV Rooms

PM3 | Broadcast Equipment Upgrade for Argentina Public Television



For its iconic cultural interview program, which has aired for over 50 years, Argentina Public Television required microphones with exceptional vocal reproduction. The upgrade was achieved using Relacart·Liacart's PM3 Dynamic Podcast Recording Microphones, meeting the program's stringent audio standards.



PROJECT APPLICATION

Entertainment and KTV Rooms



PROJECT APPLICATION

Entertainment and KTV Rooms

Ivory Red KTV



China Southern Power Grid



PROJECT APPLICATION

Entertainment and KTV Rooms

Shouguang century High School Lecture Hall



Changsha Follow KTV



PROJECT APPLICATION

Entertainment and KTV Rooms

No.8 Club



Hunan Changsha KTV



PROJECT APPLICATION

Entertainment and KTV Rooms

